

## Design Example Report

<b>Title</b>	<b>62 W Nominal Power Multi Output Flyback Converter with 3 CV Outputs Using InnoMux™2-EP IMX2379F</b>
<b>Specification</b>	90 VAC – 265 VAC Input; 5 V / 4 A, 12 V / 1 A, 24 V / 1.25 A Outputs
<b>Application</b>	Appliances and Industrial
<b>Author</b>	Applications Engineering Department
<b>Document Number</b>	DER-716
<b>Date</b>	February 26, 2024
<b>Revision</b>	1.0

---

**Power Integrations**

5245 Hellyer Avenue, San Jose, CA 95138 USA.

Tel: +1 408 414 9200 Fax: +1 408 414 9201

[www.power.com](http://www.power.com)

---

## **Summary and Features**

Unique single-stage conversion, multiple-output, flyback architecture enabling:

- High efficiency across the universal line range
- High regulation accuracy - independently regulated 5 V / 4 A, 12 V / 1 A, 24 V / 1.25 A nominal current CV outputs
- Safety features
  - Output overvoltage protection (OVP), eliminating the need for a fault protection optocoupler
  - Output power limit set independently for each output
  - Accurate thermal protection with hysteretic shutdown
  - Input voltage monitor with accurate brown-in/brown-out and overvoltage protection\
  - Audible noise is 24dBA in operation mode, and 19 dBA in standby mode

InnoMux2-EP is the industry first single chip AC/DC with isolated, safety-rated integrated multiple feedbacks. In addition, the pulse sharing significantly reduces the audible noise to enable use in quiet appliances.

The control chip incorporates isolated feedback and communication channels, combining all the benefits of secondary-side control with the simplicity of primary-side regulation.

The new architecture achieves accurate cross regulation across multiple outputs and high overall efficiency while simplifying the overall system by obviating the need for post-regulation. The single-stage converter reduces board size significantly and reduces the part count compared to the equivalent conventional converter based on multiple conversion stage topology.

### PATENT INFORMATION

The products and applications illustrated herein (including transformer construction and circuits external to the products) may be covered by one or more U.S. and foreign patents, or potentially by pending U.S. and foreign patent applications assigned to Power Integrations. A complete list of Power Integrations' patents may be found at [www.power.com](http://www.power.com). Power Integrations grants its customers a license under certain patent rights as set forth at <https://www.power.com/company/intellectual-property-licensing/>.



## Table of Contents

1	Introduction .....	5
2	High Level Schematic .....	6
3	Power Supply Specification .....	7
4	Schematic .....	8
5	Circuit Description .....	9
5.1	Input Rectifier and EMI Filter .....	9
5.2	Primary-Side .....	9
5.2.1	Primary Switch Arrangements .....	9
5.2.2	Primary-Side Controller Power Source and OVP Protection .....	9
5.2.3	Primary-Side OVP, Brown-In and Brown-Out Protection .....	9
5.2.4	Primary Peak Current Limit .....	9
5.3	Secondary-Side .....	10
5.3.1	Primary to Secondary-Side Communication .....	10
5.3.2	InnoMux2-EP Power Supply .....	10
5.3.3	Selection MOSFETs Drive .....	10
5.3.4	Output Control .....	11
5.3.5	Output Power Limiting .....	12
5.3.6	Start-Up Sequence .....	13
6	PCB Layout .....	16
7	Bill of Materials .....	18
8	Transformer (T1) and CMC (L4) Specification .....	20
8.1	Core Information .....	20
8.2	Bobbin Information .....	21
8.3	Electrical Diagram .....	22
8.4	Winding Stack Diagram .....	23
8.5	Transformer Electrical Specification .....	23
8.7	List of Materials .....	24
8.8	Transformer Construction .....	24
8.9	Transformer Test .....	25
8.10	Winding Illustration .....	26
8.11	CMC Specification .....	31
8.11.1	Electrical Diagram .....	31
8.11.2	Electrical Specifications .....	31
8.11.3	List of Materials .....	31
8.11.4	Illustration .....	31
8.12	CMC Winding Illustration .....	31
9	Performance .....	32
9.1	Current Limit Characteristic Curve .....	32
9.2	Full Load Efficiency vs. Line Input Voltage .....	33
9.3	Efficiency vs. Load .....	34
9.4	Output Load Regulation .....	35
9.5	Standby Input Power .....	38
9.6	CV Load Transient Response .....	39

9.7	Switching Waveforms.....	51
9.7.1	Primary Switch Maximum Voltage .....	51
9.7.2	Primary Switching Frequency.....	53
9.7.3	Transformer Current Waveforms.....	54
9.8	Start-Up.....	56
9.8.1	Full Load Start-up .....	56
9.8.2	No-Load Start-up .....	58
9.8.3	Start-up Under CV Fault Conditions .....	60
9.8.4	Protection Under Fault Conditions .....	61
9.8.4.1	Start-up Under CV Fault Conditions .....	62
9.9	Component Peak Voltages.....	86
9.9.1	SR FET Drain-Source Voltage.....	86
9.9.2	CV1 Selection FET Drain-Source Voltage.....	90
9.9.3	CV2 Selection FET Drain-Source Voltage.....	94
9.9.4	CV2 Rectifier Diode Reverse Voltage .....	98
9.9.5	CV3 Rectifier Diode Reverse Voltage .....	102
9.9.6	Bias Winding Rectifier Diode Reverse Voltage .....	106
9.10	Brown-Out and Brown-In .....	110
9.11	Output Protections.....	112
9.11.1	CV Output Overvoltage Protection.....	112
9.11.2	Output Ripple Measurements.....	118
9.11.3	Ripple Measurement Technique .....	118
9.11.4	CV Output Ripple .....	119
9.12	Conducted EMI .....	125
9.12.1	Line Input 115 VAC .....	125
9.12.2	Line Input 230 VAC .....	126
9.13	Thermal Performance.....	127
9.13.1	Audible Noise Performance .....	129
9.13.2	Combination Wave Surge Test .....	130
9.13.3	Differential Mode Surge (L1 to L2), 230 VAC Input.....	130
9.13.4	Common Mode Surge (L1 to PE), 230 VAC Input.....	130
9.13.5	Common Mode Surge (L2 to PE), 230 VAC Input.....	131
9.13.6	Common Mode Surge (L1+L2+PE, 230 VAC Input.....	131
10	Revision History .....	132

### Important Note:

Although this board is designed to satisfy safety isolation requirements, the engineering prototype has not been agency approved. Therefore, all testing should be performed using an isolation transformer to provide the AC input to the prototype board.

## 1 Introduction

This engineering report describes a Switch Mode Power Supply (SMPS) intended for multi-output applications. The SMPS utilizes the Power Integrations' InnoMux2-EP controller. The controller implements a multiplexing power control algorithm. Energy stored in the primary winding of the transformer during primary conduction interval is subsequently delivered to only one of the converter's main outputs (CV1, CV2 or CVHV). More specifically, this is achieved by controlling the switches SR FET, SEL1 and SEL2 (Figure 3). Utilizing a single magnetic component (transformer TX 1), the controller directs the energy flow as needed to all outputs based on respective loading requirements, thus keeping each output accurately controlled. If the energy pulse needs to be delivered to the CV1 output, SR FET and SEL1 are turned ON, if the energy pulse needs to be delivered to the CV2 output, SR FET and SEL2 are turned ON. Otherwise, if SEL1 and SEL2 are OFF, the energy is delivered to the CVHV output via the rectification diode.

The SMPS has three Constant Voltage (CV) outputs, 5 V / 4 A, 12 V / 1 A, 24 V / 1.25 A. The Power Supply Unit (PSU) can deliver a total maximum continuous output power of 62 W with universal mains input (from 90 VAC to 265 VAC).

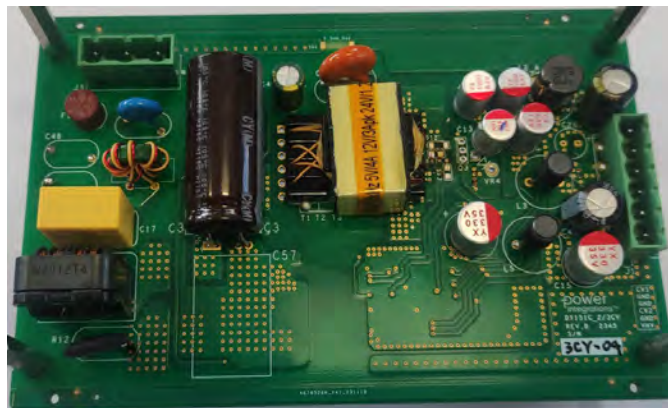

Figure 1 – PCB, Top View.

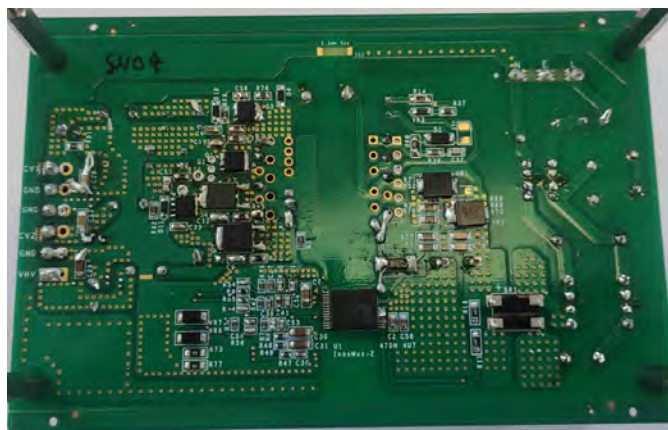
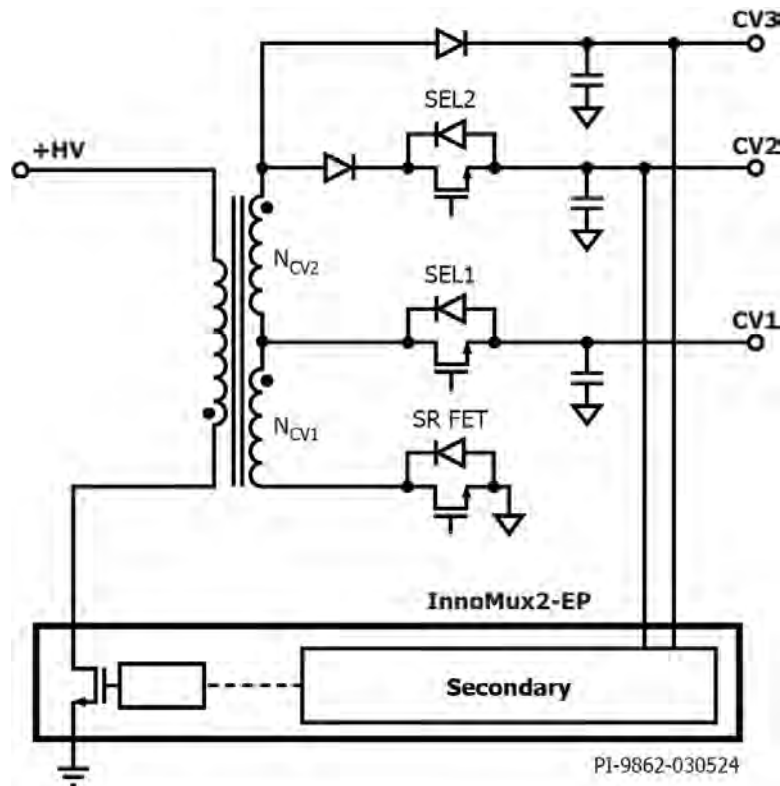

Figure 2 – PCB, Bottom View.

## 2 High Level Schematic



**Figure 3** – DER-716 High Level Schematic.

The VCV1 and VCV2 and VCVHV FB pins continuously sense the output voltages. If the voltage of any of the outputs drops below regulation level, the multi-output controller InnoMux2-EP sends a request for pulse to primary-side controller. This type of pulse-by-pulse regulation results in quick response and excellent cross regulation. For the described multiplexing algorithm to work correctly, it is essential that the reflected voltage of each winding must be higher than that of the preceding lower output voltage winding to effectively steer the power:

$$\frac{V_{CV1}}{N_{CV1}} < \frac{V_{CV2}}{N_{CV1} + N_{CV2}} < \frac{V_{CVHV}}{N_{CV1} + N_{CV2}}$$

Transformer with stacked or independent secondaries may be used as appropriate. The document contains the power supply specification, schematic, bill of materials, transformer documentation, printed circuit layout, and performance data.

### 3 Power Supply Specification

The table below represents the minimum acceptable performance of the design. The actual performance is illustrated in the results section.

Description	Symbol	Min	Typ	Max	Units	Comment
<b>Input</b>						
Voltage	$V_{IN}$	90		265	VAC	2 / 3 Wire Input.
Frequency	$f_{LINE}$	47	50/60	64	Hz	
<b>Output</b>						
Output Voltage 1	$V_{OUT1}$	4.75	5	5.25	V	±5%.
Output Ripple Voltage 1	$V_{RIPPLE1}$			150	mV	20 MHz Bandwidth.
Output Current 1	$I_{OUT1}$	0		4	A	
Output Peak Current 1	$I_{OUT1\_PK}$	0		4	A	
Output Voltage 2	$V_{OUT2}$	11.4	12	12.6	V	±5%.
Output Ripple Voltage 2	$V_{RIPPLE2}$			360	mV	20 MHz Bandwidth.
Output Current 2	$I_{OUT2}$	0		1	A	
Output Peak Current 2	$I_{OUT2\_PK}$	0		1	A	
Output Voltage 3	$V_{OUT3}$	22.8	24	25.2	V	±5%.
Output Ripple Voltage 3	$V_{RIPPLE3}$			720	mV	20 MHz Bandwidth.
Output Current 3	$I_{OUT3}$	0		1.25	A	
Output Peak Current 3	$I_{OUT3\_PK}$	0		1.25	A	
<b>Total Output Power</b>						
Continuous Output Power	$P_{OUT}$		62		W	
<b>Efficiency</b>						
Full Load	$\eta$	85			%	Measured at 115 / 230 VAC, P <sub>OUT</sub> 25 °C.
No-Load Input Power				<0.3	W	Measured at 230 VAC 25 °C, 5 V 30 mA
<b>Environmental</b>						
Conducted EMI Safety		Meets CISPR22B / EN55022B				
Surge Common Mode				2	kV	Combination Wave, 12 Ω Common Mode.
Surge Differential Mode				1	kV	Combination Wave, 2 Ω Differential Mode.
Ambient Temperature	$T_{AMB}$	0		40	°C	Free Convection, Sea Level.

### 4 Schematic

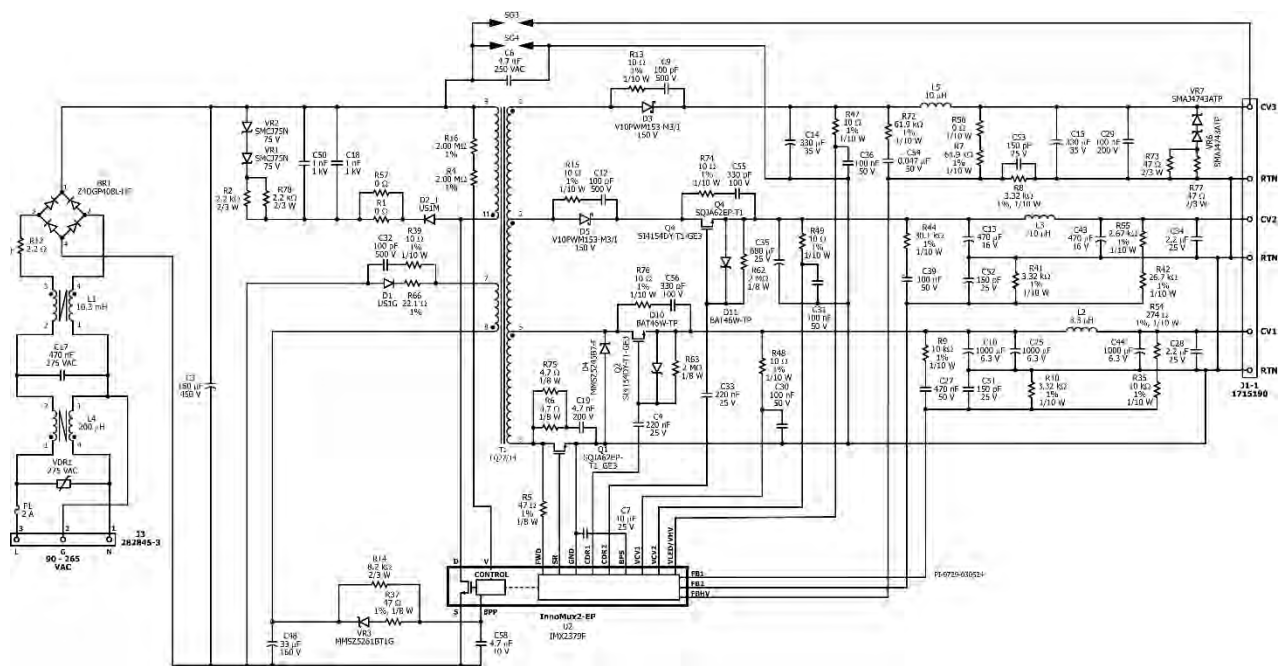

Figure 4 – Schematic.





## 5 Circuit Description

### 5.1 Input Rectifier and EMI Filter

Fuse F1 isolates the circuit and provides protection from component failure, and the common mode chokes L1 and L4 with capacitor C17 attenuation for EMI. Bridge rectifier BR1 rectifies the AC line voltage and provides a full wave rectified DC voltage across the filter capacitor C3. Varistor VDR1 provides protection against differential voltage surges. Resistor R12 (NTC) limits the inrush current. Capacitor C6 is used to mitigate the common mode EMI.

### 5.2 Primary-Side

#### 5.2.1 Primary Switch Arrangements

The transformer primary is connected between the input DC bus (TXPRI+) and the drain D of the integrated primary switch of InnoMux2-EP (U1 pin 28).

A Zener type primary clamp (VR1, VR2, R2, R78, C50, C18) is used to limit the peak drain voltage of U1 at the instant of turn-off of the switch inside U1.

#### 5.2.2 Primary-Side Controller Power Source and OVP Protection

The primary-side controller is part of the InnoMux2-EP (U1). It is self-starting, using an internal high-voltage current source to charge the BPP capacitor C58, when AC voltage is first applied to the converter input. During normal operation (steady-state) the primary-side of the controller is powered from an auxiliary winding on the main transformer. The voltage across this winding is rectified and filtered using diode D1 and capacitor C48, and then connected to the BPP pin via a current limiting resistor R14.

#### 5.2.3 Primary-Side OVP, Brown-In and Brown-Out Protection

A crude primary-side output overvoltage protection (OVP) is implemented by Zener diode VR3 and the series resistor R37. In the event of an uncontrolled overvoltage at the output, the auxiliary winding voltage increases and causes breakdown of VR3 which then causes a current to flow into the BPP pin of IC U1. If this current exceeds  $I_{SD}$  threshold, InnoMux2-EP controller will latch off and prevent any further increase in output voltage.

Resistor R11 and R16 provide input voltage sense protection for undervoltage and overvoltage conditions.

#### 5.2.4 Primary Peak Current Limit

The value of capacitor C58 is used to set the maximum primary current to STANDARD or to INCREASED level. In this case 4.7  $\mu$ F capacitance sets the primary-side controller peak current limit to its INCREASED level of 2.45 A.

### 5.3 Secondary-Side

The secondary-side of the InnoMux2-EP IC (U1) is powered from the 5 V BPS rail generated internally. Capacitor C7 is a local decoupling capacitor.

#### 5.3.1 Primary to Secondary-Side Communication

The secondary-side of the InnoMux2-EP IC (U1) sends a request to the primary-side controller to initiate a switching cycle, by sending a pulse via the internal FluxLink™, a galvanically isolated communication channel.

#### 5.3.2 InnoMux2-EP Power Supply

During start-up the InnoMux2-EP secondary-side controller is powered from FWD / VCVHV / VCV2 rail via R47 / R49. There is a local decoupling capacitor C36 and C31 connected close to the VCVHV and VCV2 pins of U1. Resistor R47 and R49 values and C36 and C31 are optional. An internal regulator reduces the VCVHV / VCV2 voltage to 5 V and outputs it to the BPS bus (U1 pin 6).

In steady-state the voltage on VCV1 is 5 V and there is a special case in the InnoMux2-EP (U1) IC, BPS direct power mode. When BPS voltage is within a suitable range (4.75 to 5.5 V), BPS voltage is supplied by CV1. Efficiency can be improved by using BPS direct power mode.

#### 5.3.3 Selection MOSFETs Drive

The gate drive amplitude for the selection MOSFETs Q2 is approximately equal to the voltage on the BPS rail (5 V). Consequently, logic level MOSFET is used. Capacitor C4 is charged up to the level of the  $V_{CV1}$  from the CV1 via diode (D10) to the CDR1 pin. When the selection 1 MOSFET needs to be gated on, CDR1 pin voltage is raised from GND to BPS, and the selection MOSFET gate voltage (the other terminal of the capacitor C4) is lifted to  $V_{CV1} + V_{BPS}$ .

The gate drive amplitude for the selection MOSFETs Q4 is approximately equal to the voltage on the BPS rail (5 V). Consequently, logic level MOSFET is used. Capacitor C33 is charged up to the level of the  $V_{CV2}$  from the CV2 via diode (D11) to the CDR2 pin. When the selection 2 MOSFET needs to be gated on, CDR2 pin voltage is raised from GND to BPS, and the selection MOSFET gate voltage (the other terminal of the capacitor C33) is lifted to  $V_{CV2} + V_{BPS}$ .

The secondary control circuit in InnoMux2-EP IC needs access to the idle ring waveform to calculate its timing and facilitate valley switching. Such access is ensured through the FW pin by keeping Q1 on after the secondary conduction time has expired.

#### 5.3.4 Output Control

Output rectification for the CV1 output is provided by the SR MOSFET Q1 and the CV1 selection MOSFET Q2. A  $\Pi$  – type LC filter (C10, C25, C44, C28 and L2) ensures low output ripple voltage. The first stage filter capacitors C10, C25, C44 have low ESR to minimize the switching noise. A small multilayer ceramic (MLCC) capacitor C28 is connected across the CV1 output terminals and provides low impedance bypass for any high frequency noise components.

Output rectification for the CV2 output is provided by the SR MOSFET Q1 and the CV2 selection MOSFET Q4 and diode D5. A  $\Pi$  – type LC filter (C35, C13, C43, C34 and L3) ensures low output ripple voltage. The first stage filter capacitors C35, C13, C43 have low ESR to minimize the switching noise. A small multilayer ceramic (MLCC) capacitor C34 is connected across the CV2 output terminals and provides low impedance bypass for any high frequency noise components.

Output rectification for the CVHV output is provided by the SR MOSFET Q1 and the CVHV rectifying diode D3. A  $\Pi$  – type LC filter (C14, C15, C29 and L5) ensures low output ripple voltage. The first stage filter capacitors C14 and C15 have low ESR to minimize the switching noise. A small multilayer ceramic (MLCC) capacitor C29 is connected across the CVHV output terminals and provides low impedance bypass for any high frequency noise components.

The V CV1 output voltage is set by R54, R35 and R10 to FB1 (U1 pin 1). Loop compensation is provided by R9 and C27 due to the inclusion of L2. High frequency noise is decoupled by capacitor C51.

The V CV2 output voltage is set by R55, R42 and R41 to FB2 (U1 pin 3). Loop compensation is provided by R44 and C39 due to the inclusion of L3. High frequency noise is decoupled by the capacitor C52.

The V CVHV output voltage is set by R56, R7 and R8 to FB3 (U1 pin 8). Loop compensation is provided by R72 and C54 due to the inclusion of L5. High frequency noise is decoupled by capacitor C53.

High-frequency ringing during switching transients that would otherwise create radiated EMI is reduced in SR MOSFET via an RC snubber formed by resistors R6 and R75 and capacitor C19.

High-frequency ringing during switching transients that would otherwise create radiated EMI is reduced in SEL1 MOSFET via an RC snubber formed by resistors R76 and capacitor C56.

High-frequency ringing during switching transients that would otherwise create radiated EMI is reduced in SEL2 MOSFET via an RC snubber formed by resistors R74 and capacitor C55.

High-frequency ringing during switching transients that would otherwise create radiated EMI is reduced in CV2 diode via an RC snubber formed by resistors R15 and capacitor C12.

High-frequency ringing during switching transients that would otherwise create radiated EMI is reduced in CVHV diode via an RC snubber formed by resistors R13 and capacitor C9.

Zener diode D4 is used as a voltage clamp for the transformer CV1 winding.

Zener diodes VR6 and VR7 are used to limit the maximum CVHV voltage which can be predominantly caused by the leakage in the transformer.

#### 5.3.5 Output Power Limiting

A power limit is implemented individually for each output and set by controller configuration (InnoMux2-EP IC). Power limit is disabled by default. The power delivered to any of the outputs is restricted by limiting the maximum average frequency at which an output can receive. Namely, power limit bits set the frequency limit for output CV1, CV2 and CVHV. If the frequency is exceeded for a predetermined time interval, the InnoMux2-EP controller will execute auto-restart or latch-off.

5.3.6 Start-Up Sequence

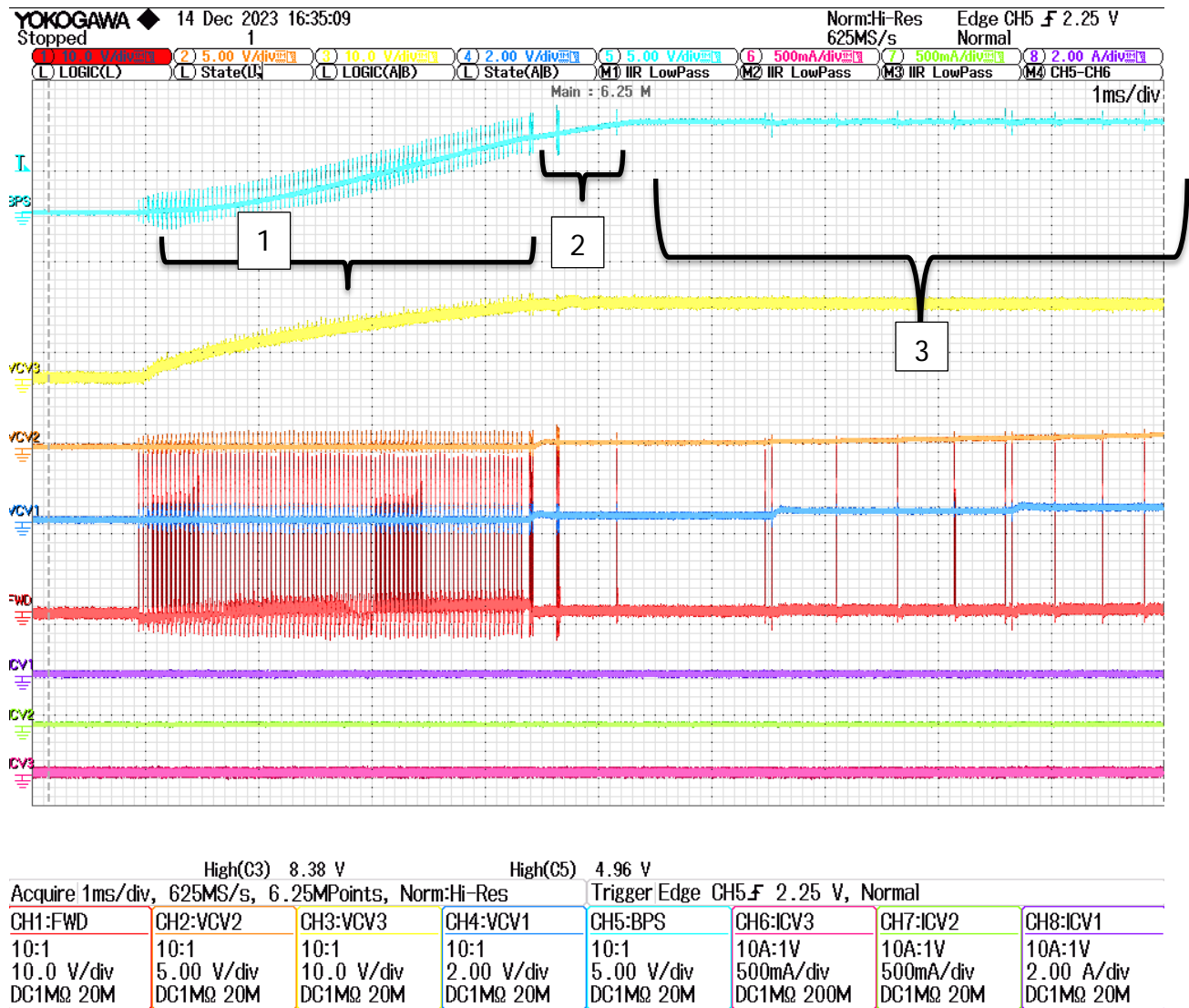

Figure 5 – First 10 ms of Start-Up.

1. The secondary-side controller is powered-down (asleep). The primary-side controller operates open-loop at a fixed frequency of about 25 kHz. The peak current is set to approximately 30% of its maximum level. If the secondary-side does not wake up and respond, the primary-side will:
  - a. time out and shut down, or
  - b. the primary-side bias voltage will rise high enough to trigger a bias OVP shutdown.
2. The CVHV output is the only output to rise significantly during interval 1. It can provide power to InnoMux2-EP (U1) internal secondary voltage regulator (BPS regulator), which generates the internal supply bus BPS (+5 V). Eventually the internal voltage regulator establishes 5 V at the BPS pin. IC U1 secondary-side controller then wakes up from its power-on-reset and start hand-shaking with the primary controller to take over the control of InnoMux2-EP IC. Hand-shaking pulse and SEL signals to indicate the handshake. Also need to point out what happens to secondary if handshake failed.
3. After hand-shaking, the fixed 25 kHz switching frequency is ended, and InnoMux2-EP (U1) switching according to the feedback and reference voltages on CV1, CV2 and CVHV(CV3). The CV1 and CV2 voltages are linearly raised, while the CV3 voltage is maintained at the stay-alive voltage ( $V_{\text{STAYALIVE}}$ , ~8.0 V) to provide input to the internal BPS regulator. While the VCV1 and VCV2 are raised to the same reference percentage as the VCV3, InnoMux2-EP IC (U1) starts ramping up both of the three output voltages simultaneously (VCV1, VCV2 and VCV3) to their references.
4. CV1, CV2 and CV3 output voltages can be seen to rise simultaneously at interval 4 until reaching their FB voltage levels .

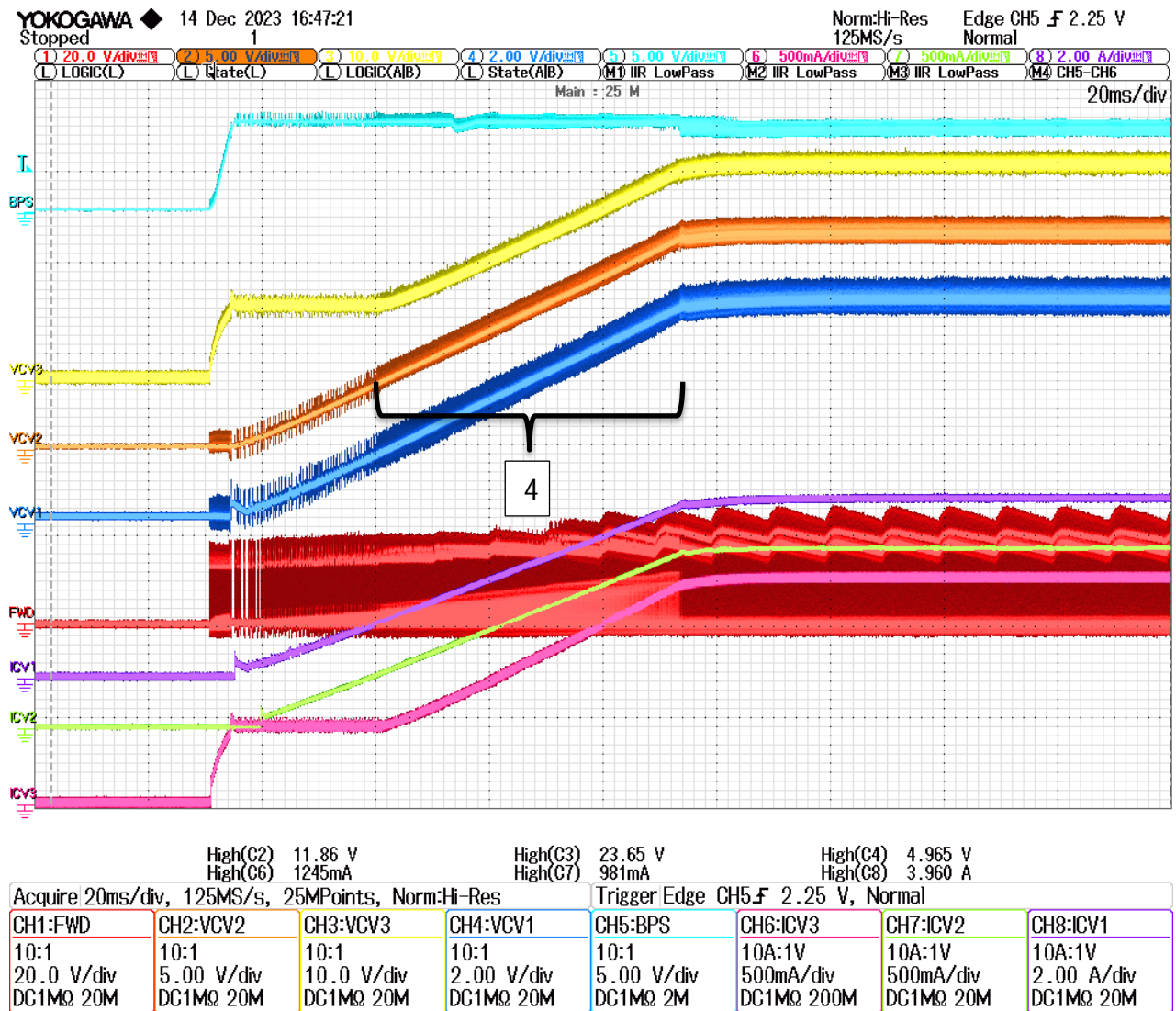

Figure 6 – Complete Start-Up Cycle.





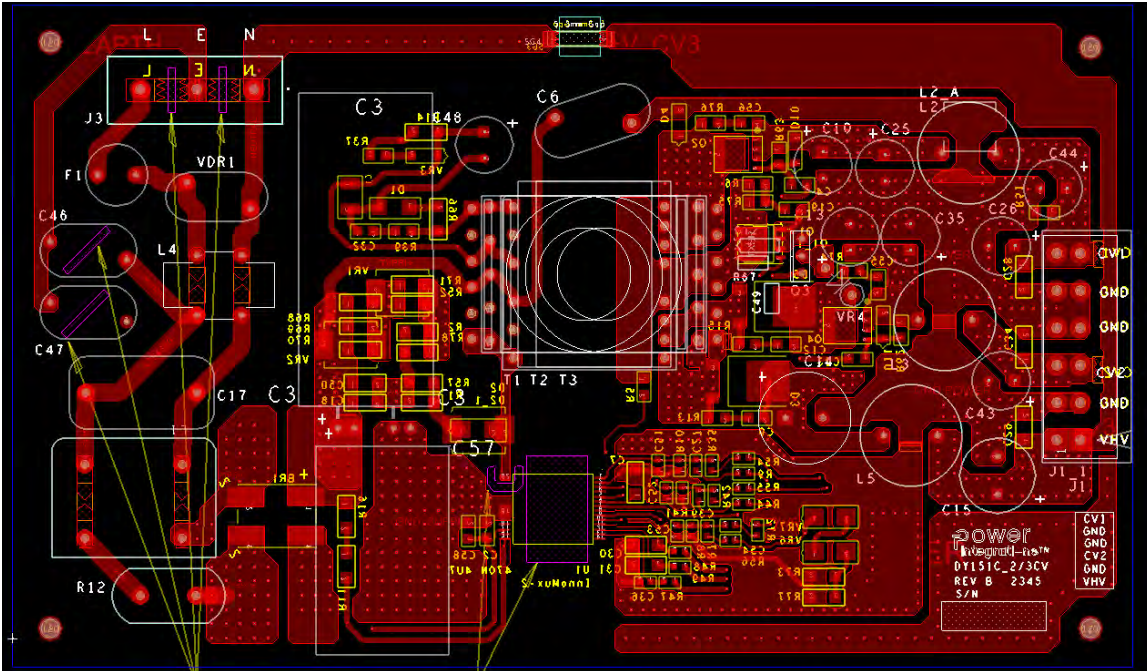

Figure 8 – Printed Circuit Layout, Bottom.

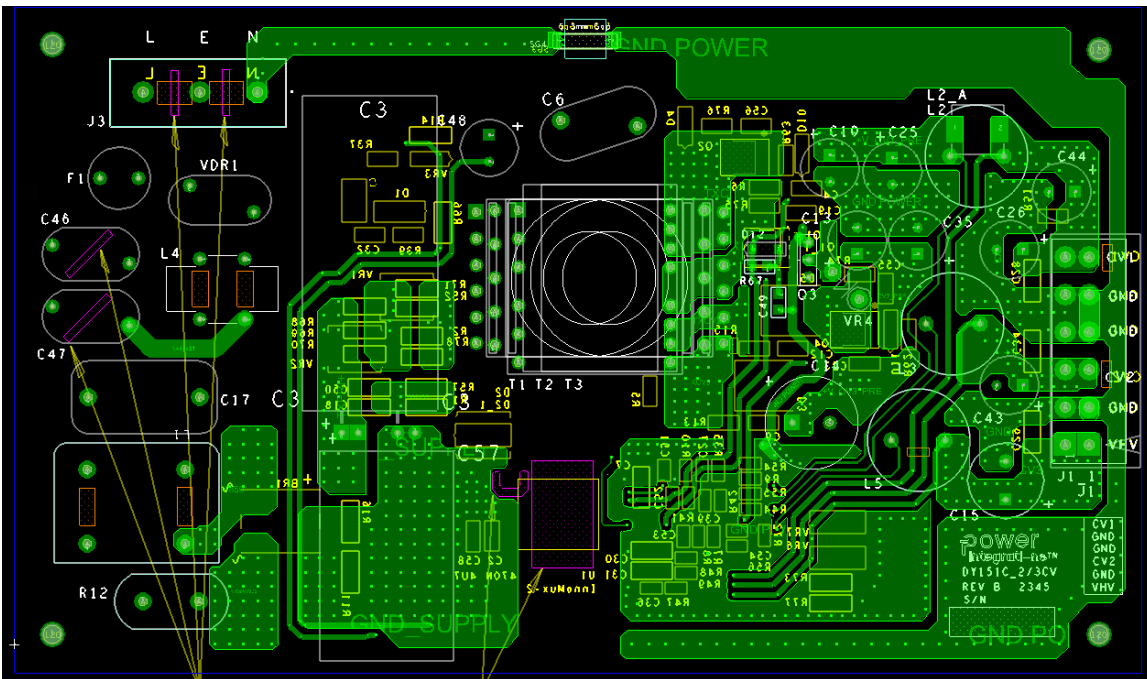

Figure 9 – Printed Circuit Layout, Top.

## 7 Bill of Materials

Item	Qty	Ref Des	Description	Mfg Part Number	Mfg
1	1	BR1	RECT BRIDGE, GP, 800 V, 4 A, Z4-D	Z4DGP408L-HF	Comchip
2	1	C3	150 $\mu$ F, 450 V, Electrolytic, (18 x 40)	UPH2W151MHD	Nichicon
3	2	C4 C33	220 nF, 25 V, Ceramic, X7R, 0805	CC0805KRX7R8BB224	Yageo
4	1	C6	4.7 nF, Ceramic, Y1	440LD47-R	Vishay
5	1	C7	10 $\mu$ F, $\pm$ 10%, 25 V, Ceramic Capacitor X7R, 1206	C1206C106K3RACAUTO	KEMET
6	3	C9 C12 C32	100 pF, 500 V, Ceramic, NP0, 0805	501R15N101KV4T	Johanson Dielectrics
7	2	C10 C25	1000 $\mu$ F, 20%, 6.3 V, Al Organic Polymer, Gen. Purpose, 2000 Hrs @ 105°C, (8 x 8 mm)	RL80J102MDN1KX	Nichicon
8	1	C13	470 $\mu$ F, 16 V, Al Organic Polymer, 12 m $\Omega$ , (8 x 11.5)	RNE1C471MDN1	Nichicon
9	2	C14 C15	330 $\mu$ F, $\pm$ 20%, 35 V, Aluminium Polymer Capacitor Radial, Can, 18 m $\Omega$ , 1000 Hrs @ 125°C	35SEK330M	Panasonic
10	1	C17	470 nF, 275 VAC, Film, X2	80-R46KI347050P1M	Kemet
11	2	C18 C50	1 nF, 1000 V, Ceramic, X7R, 1206	CC1206KKX7RCBB102	Yageo
12	1	C19	4700 pF, $\pm$ 10%, 200 V, Ceramic Capacitor, X7R, 0805	C0805C472K2RECAUTO	KEMET
13	1	C27	470 nF, 50 V, Ceramic, X7R, 0603	UMK107B7474KA-TR	Taiyo Yuden
14	2	C28 C34	2.2 $\mu$ F, $\pm$ 10%, 25 V, Ceramic, X7R, 1206	12063C225K4Z2A	AVX Murata
15	1	C29	100 nF, 200 V, Ceramic, X7R, 1206	VJ1206Y104KXCAT	Vishay
16	2	C30 C31	100 nF, 50 V, Ceramic, X7R, 1206	CC1206KRX7R9BB104	Yageo
17	1	C35	680 $\mu$ F, 25 V, Aluminium-Polymer, 16m $\Omega$ , 2000 Hrs @ 105 °C, (8 x 16)	A750KW687M1EAAE016	KEMET
18	2	C36 C39	0.1 $\mu$ F (100 nF) $\pm$ 10% 50 V Ceramic Capacitor X7R 0603	GCM188R71H104KA57D	Murata
19	1	C43	470 $\mu$ F, 16 V, Electrolytic, Very Low ESR, 53 m $\Omega$ , (8 x 15)	EKZE160ELL471MH15D	Nippon Chemi-Con
20	1	C44	1000 $\mu$ F, 6.3 V, Electrolytic, Gen Purpose, (8 x 11.5)	ECA-0JHG102	Panasonic
21	1	C48	33 $\mu$ F, $\pm$ 20%, 160 V, Al Electrolytic, (8 x 14)	EGW2CM330F140T	AiSHi
22	3	C51 C52 C53	150 pF, 5%, 250 V, Ceramic, COG, 0603	C1608COG2E151J080AA	TDK
23	1	C54	0.047 $\mu$ F, $\pm$ 10%, 50 V, Ceramic Capacitor X7R, 0603	C0603C473K5RAC7867	KEMET
24	1	C55	330 pF, 500 V, Ceramic, X7R, 0805	C0805C331KCRACU	Panasonic
25	1	C56	330 pF, $\pm$ 10%, 100 V, Ceramic, X7R, 0805	C0805C331K1RACTU	Kemet
26	1	C58	4.7 $\mu$ F $\pm$ 10% 10V Ceramic Capacitor X7R 0805	LMK212B7475KGHT	Taiyo Yuden
27	1	D1	Diode ULTRA FAST, GPP, 400 V, 1 A SMA	US1G-13-F	Diodes, Inc.
28	1	D2_1	Diode, Standard, 1000 V, 1 A, SMT DO-214AC (SMA)	US1M-TP	Micro Commercial
29	2	D3 D5	Diode, Schottky, 150 V, 10 A, SMT Slim DPAK, TO-252AE	V10PWM153-M3/I	Vishay
30	1	D4	Diode ZENER 15 V 500 mW SOD123	MMSZ5245B-7-F	Diodes, Inc.
31	2	D10 D11	Diode, Schottky, 100 V, 0.075 A, SOD123	BAT46W-TP	Micro Commercial
32	1	F1	2 A, 250 V, Slow, TR5	37212000411	Wickman
33	1	J1_1	6 Position (1 x 6) header, 5 mm (0.196) pitch, Vertical	1715190	Phoenix Contact
34	1	J3	3 Position Wire to Board Terminal Block (7.62 mm)	282845-3	TE Connectivity
35	1	L1	CMC 10.3 MH 2.0 A 0.15 $\Omega$ WIDE IMP	SSR21NVS-M20103	KEMET
36	1	L2	FIXED IND, 3.3 $\mu$ H, $\pm$ 20%, 5.2 A, 16 M $\Omega$ , TH	ELC10D3R3E	Panasonic
37	2	L3 L5	10 $\mu$ H, Unshielded Wirewound Inductor, 3.45 A, 15 m $\Omega$ Max, Radial, Vertical Cylinder	18R103C	Murata Power





38	1	L4	200 $\mu$ H @ 100 kHz Common Mode Choke	30-00512-00	Power Integrations
39	2	Q1 Q4	MOSFET, N-Channel, 60 V, 60 A (Tc), 68 W (Tc), PowerPAK® SO-8	SOJA62EP-T1_GE3	Vishay
40	1	Q2	MOSFET, N-Channel, 40 V, 36 A (Tc), 3.5 W (Ta), 7.8 W (Tc), SO-8	SI4154DY-T1-GE3	Vishay
41	2	R1 R57	RES, 0 $\Omega$ , Jumper, 1/4 W, Chip Resistor 1206	RC1206JR-070RL	Yageo
42	2	R2 R78	RES, 2.2 k $\Omega$ , 5%, 2/3 W, Thick Film, 1206	ERJ-P08J222V	Panasonic
43	2	R5 R37	RES, 47.0 $\Omega$ , 1%, 1/8 W, Thick Film, 0805	ERJ-6ENF47R0V	Panasonic
44	2	R6 R75	RES, 4.7 $\Omega$ , 5%, 1/8 W, Thick Film, 0805	ERJ-6GEYJ4R7V	Panasonic
45	2	R7 R72	RES, 61.9 k $\Omega$ , 1%, 1/10 W, Thick Film, 0603	ERJ-3EKF6192V	Panasonic
46	3	R8 R10 R41	RES, 3.32 k $\Omega$ , 1%, 1/10 W, Thick Film, 0603	ERJ-3EKF3321V	Panasonic
47	2	R9 R35	RES, 10.0 k $\Omega$ , 1%, 1/10 W, Thick Film, 0603	ERJ-3EKF1002V	Panasonic
48	2	R11 R16	RES, 2.00 M $\Omega$ , 1%, 1/4 W, Thick Film, 1206	ERJ-8ENF2004V	Panasonic
49	1	R12	NTC Thermistor, 1.3 $\Omega$ , 7 A	MF72-001.3D13	Cantherm
50	5	R13 R15 R39 R74 R76	RES, 10 $\Omega$ , 1%, 1/8 W, Thick Film, 0805	ERJ-6ENF10R0V	Panasonic
51	1	R14	RES, 8.2 k $\Omega$ , 5%, 2/3 W, Thick Film, 1206	ERJ-P08J822V	Panasonic
52	1	R42	RES, 26.7 k $\Omega$ , 1%, 1/10 W, Thick Film, 0603	ERJ-3EKF2672V	Panasonic
53	1	R44	RES, 30.1 k $\Omega$ , 1%, 1/10 W, Thick Film, 0603	ERJ-3EKF3012V	Panasonic
54	3	R47 R48 R49	RES, 10 $\Omega$ , 1%, 1/10 W, Thick Film, 0603	ERJ-3EKF10R0V	Panasonic
55	1	R54	RES, 274 $\Omega$ , 1%, 1/10 W, Thick Film, 0603	ERJ-3EKF2740V	Panasonic
56	1	R55	RES, 2.67 k $\Omega$ , 1%, 1/10 W, Thick Film, 0603	ERJ-3EKF2671V	Panasonic
57	1	R56	RES, 0 $\Omega$ Jumper, 1/10 W Chip Resistor 0603	RC0603FR-070RL	Yageo
58	2	R62 R63	RES, 2 M $\Omega$ , 5%, 1/8 W, Thick Film, 0805	ERJ-6GEYJ205V	Panasonic
59	1	R66	RES, 22.1 $\Omega$ , 1%, 1/4 W, Thick Film, 1206	ERJ-8ENF22R1V	Panasonic
60	2	R73 R77	RES, 47 $\Omega$ , 5%, 2/3 W, Thick Film, 1206	ERJ-P08J470V	Panasonic
61	1	T1	Bobbin, EQ27/14, 11 pins, 6pri, 5sec	YT-2701	<a href="http://www.dqytdz.com">www.dqytdz.com</a>
62	1	U2	InnoMux2-EP, InSOP-T28D (No EP)	IMX2379F	Power Integrations
63	1	VDR1	275 VAC, 5 J, 10 mm, RADIAL	V275LA10P	Littlefuse
64	2	VR1 VR2	TVS Diode, Unidirectional, 75 V Reverse Standoff, 121 V Clamp (DO-214AB)	SMCJ75A	Littlefuse
65	1	VR3	Diode ZENER 47 V 500 mW SOD123	MMSZ5261BT1G	ON Semi
66	2	VR6 VR7	Zener Diode, 13 V, 1 W, $\pm$ 5%, SMT DO-214AC (SMA)	SMAJ4743A-TP	Micro Commercial

## 8 Transformer (T1) and CMC (L4) Specification

### 8.1 Core Information

Core EQ27/14, Guangzhou Tongyang Electronics Part No. 066260270718044

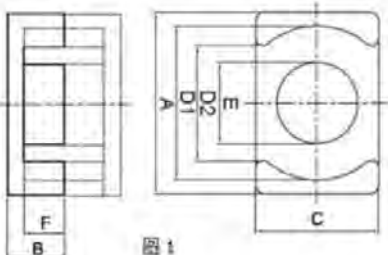
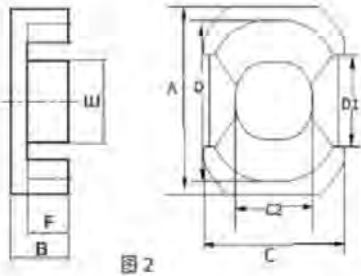
 <b>广州市通洋电子有限公司</b> <b>Guangzhou Tongyang Electronics Co.,Ltd</b> 地址: 中国广东省广州市白云区松北工业区社前路56号1栋 Add: 1st Building, No.56Sheqian Road, Songbe Industrial Zone, Baiyun District, Guangzhou, China Tel: +86 020-81786686    Web: <a href="http://www.gztydz.com">http://www.gztydz.com</a> E-mail: <a href="mailto:ywb@gztydz.com">ywb@gztydz.com</a>			
   	代 码 Code	066260270718044	
	型 号 Type	EQ27/14	
	尺寸 (mm) Dimension	A	26.70 ± 0.40
		B	6.85 ± 0.20
		C	18.1 ± 0.30
		C2	*
		D	*
		D1	23.10min
		D2	18.90min
		E	11.10 ± 0.20
	F	4.45 ± 0.20	
	B-F	2.40 ± 0.20	
图 drawing	1		
可调尺寸 adjustable dimension			
磁芯常数Cl (mm <sup>-1</sup> ) Core Factor	0.45		
有效磁路长度 Le (mm) Effective length Le	39.16		
有效截面积 Ae (mm <sup>2</sup> ) Effective Area	85.88		
有效体积 Ve (mm <sup>3</sup> ) Effective Volume	3363		
重量 W (g/set) Weight			
电感系数 AL (nH/N <sup>2</sup> ) ± 25%	TY40		
	TY44	5000	
	TY95		
功率损耗 Core loss	TY40		
	TY44		
	TY95		

磁芯可按客户尺寸开模，可以开气隙。

We can open the mould or grind air gap for the ferrite core as per customer's requirement and size.

Figure 10 – EQ27/14 Core.

8.2 Bobbin Information

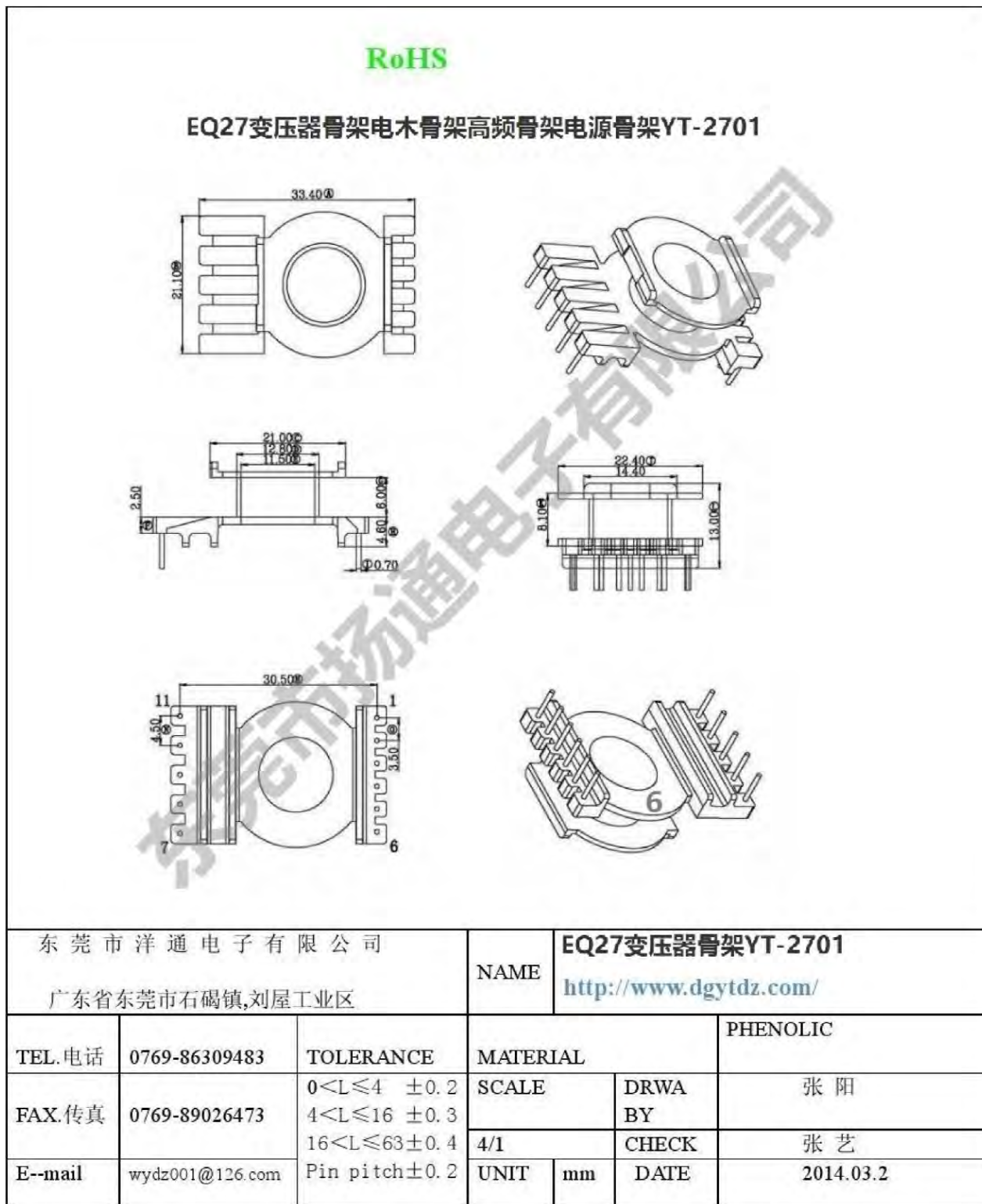

Figure 11 – Guangzhou Tongyang Electronics – 11 Pin Bobbin – YT-2701.

### 8.3 Electrical Diagram

Pin number 5 and pin number 6 need to be short-circuited on PCB board.

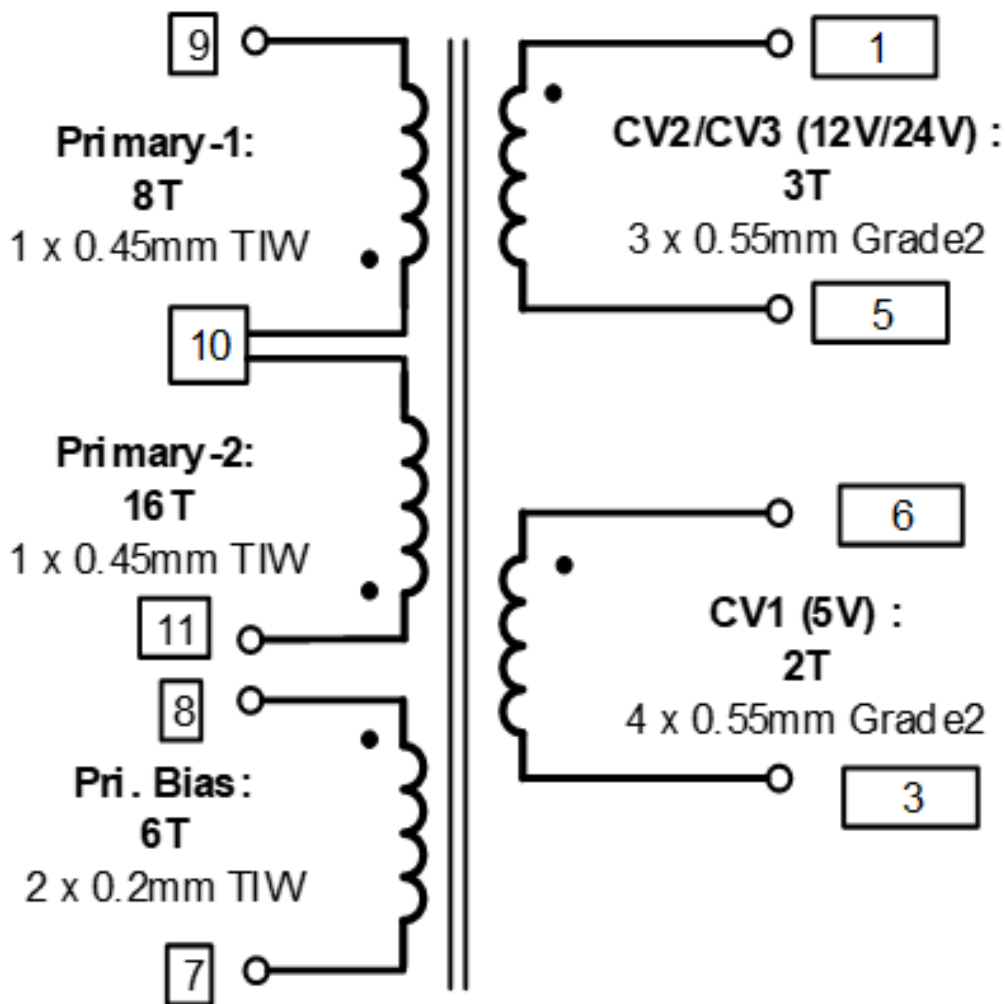

Figure 12 – Transformer Electrical Diagram.

### 8.4 Winding Stack Diagram

**Note:**

Unless stated otherwise **hobbin** turns **anti-clock-wise** looked from the pins' end.

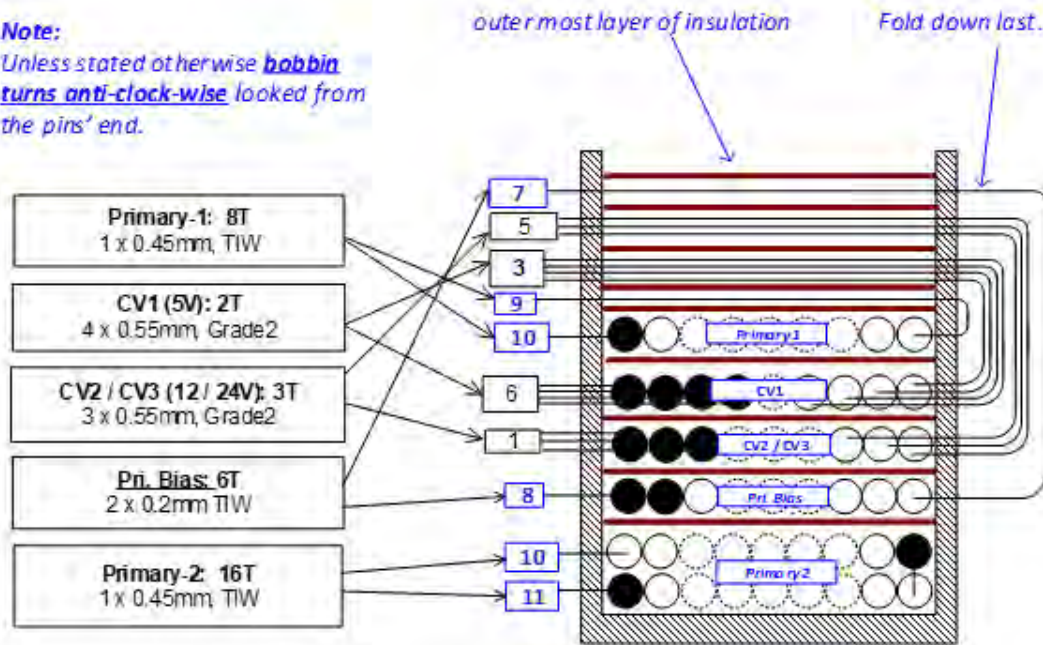

Figure 13 – Transformer Build Diagram.

### 8.5 Transformer Electrical Specification

Parameter	Condition	Spec.
<b>Electrical strength</b>	1 second, 60 Hz from pins 1-6 to 7-13.	3000 VAC
<b>Nominal Primary Inductance</b>	Measured at 1 VPK-PK, 100 kHz switching frequency, between pin 9 and 11, with all other windings open.	188 $\mu$ H $\pm$ 5%
<b>Resonant Frequency</b>	Between pin 9 and 11, other windings open.	1100 kHz (Min.)
<b>Primary Leakage Inductance</b>	Between pin 9 and 11, with all secondary 1,3,5 and 6 are shorted.	9 $\mu$ H (Max.)

### 8.7 List of Materials

Item	Description	Quantities
[1]	Core: Ferroxcube Part No. EQ27/14 TY44.	2
[2]	Bobbin: EQ27 YT-2701.	1
[3]	Magnet Wire: 0.55 mm ECW Gr 2.	
[4]	Magnet Wire: 0.45 mm, Triple Insulated Wire.	
[5]	Magnet Wire: 0.2 mm, Triple Insulated Wire.	
[6]	Barrier Tape: Polyester Film, 2.5±0.5 mil thickness, 6 mm Wide.	
[7]	Varnish: MR8008B - Varnish, Insulating, Polyurethane, Transparent/Amber EMR8008B250ML Or BC-359.	

### 8.8 Transformer Construction

<b>Layer 1&amp;2 Primary-1</b>	Start at pin 11, wind 16 turns of 1 wire Item [4] in 2 layers with tight tension. Terminate at pin 10.
<b>Insulation</b>	Place 1 layers of tape Item [6] for insulation.
<b>Layer 3 Primary Bias</b>	Start at pin 8, wind 6 turns of 2 wire Item [5] in 1 layer with tight tension. Cut to leave about 5cm and tape to mandrel bobbin
<b>Insulation</b>	Place 1 layer of tape Item [6] for insulation.
<b>Layer 3 CV2&amp;CV3</b>	Start at pin 1, wind 3 turns of 3 wire Item [3] in 1 layer with tight tension. Cut to leave about 5 cm and tape to mandrel bobbin
<b>Insulation</b>	Place 1 layer of tape Item [6] for insulation.
<b>Layer 4 CV1</b>	Start at pin 6, wind 2 turns of 4 wire Item [3] in 1 layer with tight tension. Cut to leave about 5 cm and tape to mandrel bobbin
<b>Insulation</b>	Place 1 layer of tape Item [6] for insulation.
<b>Layer 6 Primary-2</b>	Start at pin 10, wind 8 turns of 1 wire Item [4] in 1 layer with tight tension. Terminate at pin 9.
<b>Insulation</b>	Place 1 layer of tape Item [6] for insulation.
<b>Termination</b>	Terminate the CV1 windings at pin number 3.
<b>Termination</b>	Terminate the CV2/CV3 winding at pin number 5.
<b>Termination</b>	Terminate primary bias winding at pin number 7.
<b>Insulation</b>	Place 2 layers of tape Item [6] for insulation.
<b>Finish Assembly</b>	Gap core halves to 188 $\mu$ H $\pm$ 3% inductance. Insert cores and tape tightly together Item [8]. Label "XXX.X $\mu$ H" (XXX.X = measured primary inductance value in $\mu$ H) Varnish – Item [11].









### 8.9 Transformer Test

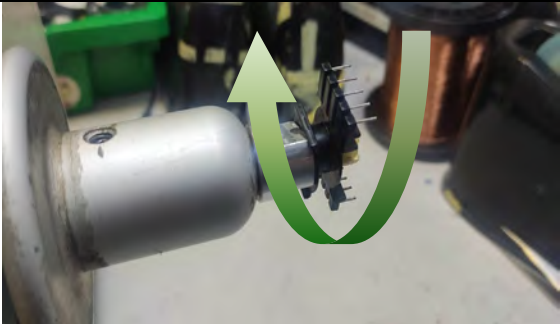

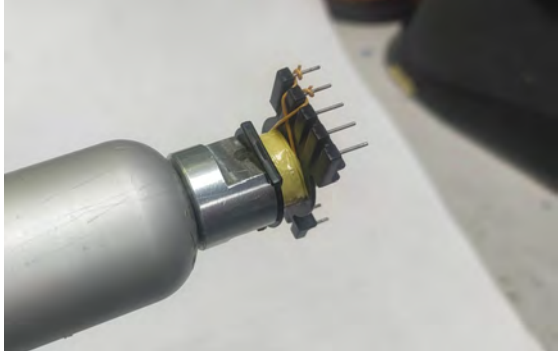
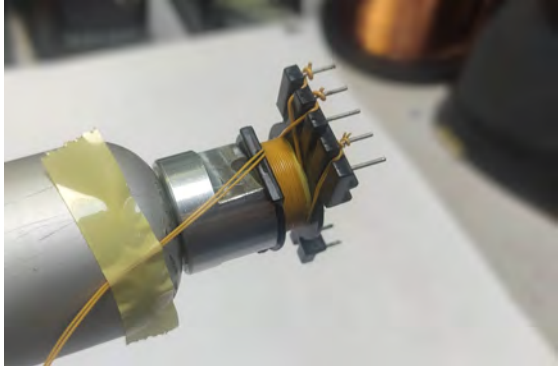
The winding measured inductance of the individual windings as well as the primary leakage inductance of the transformer are shown in the table below:

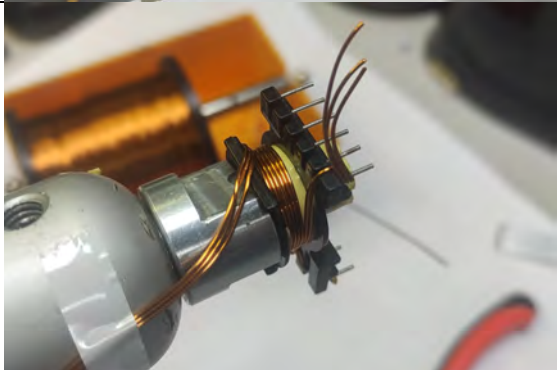
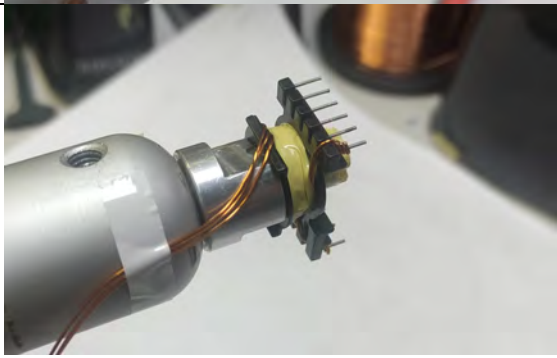

		Between Pins	Pins Shorted
Lpri [ $\mu\text{H}$ ]	186.4	9 - 11	
LCV1 [ $\mu\text{H}$ ]	1.61	3 - 6	
LCV2/CV3 [ $\mu\text{H}$ ]	8.5	1 - 3	
L1aux [ $\mu\text{H}$ ]	10.3	7 - 8	
Llkg1 [ $\mu\text{H}$ ]	7.5	9 - 11	1, 3, 5 and 6

**8.10 Winding Illustration**

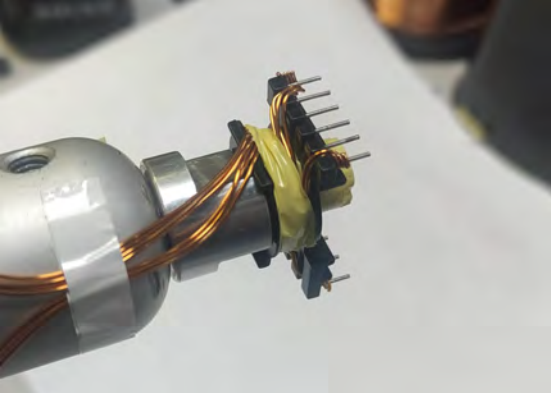
		<p>Place the bobbin on the mandrel with the pin side to the right. Winding direction is in the clockwise direction i.e.</p>
<p><b>Wind 1 Primary 1 2/3 Primary</b></p>		<p>Start at pin 11, wind 16 turns of 1 wire Item [4] in 2 layers with tight tension. Terminate at pin 10.</p>
<p><b>Insulation layer</b></p>		<p>Place 1 layers of tape Item [6] for insulation.</p>
<p><b>Wind 2 Primary Bias</b></p>		<p>Start at pin 8, wind 6 turns of 2 wire Item [5] in 1 layer with tight tension. Cut to leave about 5cm and tape to mandrel bobbin.</p>

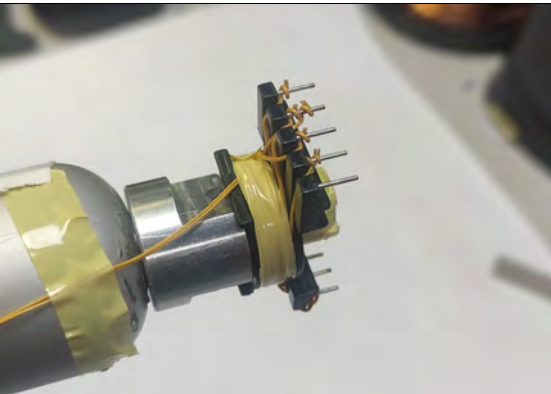
<p><b>Insulation layer</b></p>		<p>Place 1 layers of tape Item [6] for insulation.</p>
<p><b>Wind 3 CV2/CV3 Winding</b></p>		<p>Start at pin 1, wind 3 turns of 3 wire Item [3] in 1 layer with tight tension. Cut to leave about 5 cm and tape to mandrel bobbin</p>
<p><b>Insulation layer</b></p>		<p>Place 1 layers of tape Item [6] for insulation.</p>
<p><b>Wind 4 CV1 Winding</b></p>		<p>Start at pin 6, wind 2 turns of 4 wire Item [3] in 1 layer with tight tension. Cut to leave about 5 cm and tape to mandrel bobbin</p>

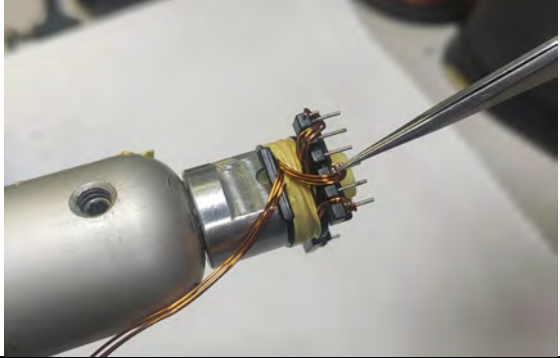
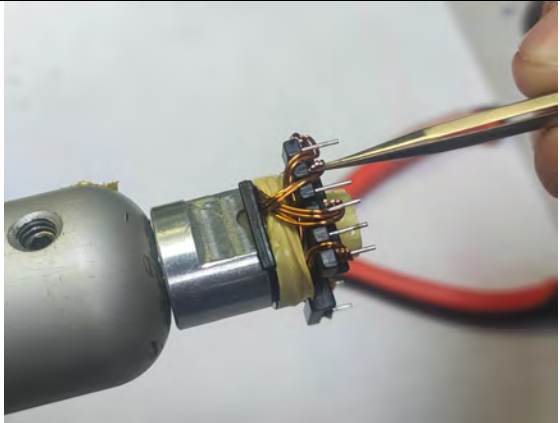
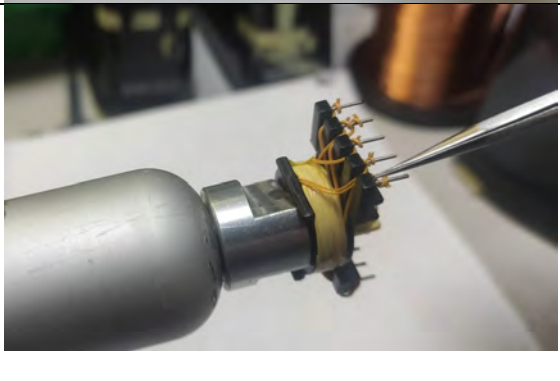
<p><b>Insulation layer</b></p>		<p>Place 1 layers of tape Item [6] for insulation.</p>
<p><b>Wind 5 Primary 2 1/3 Primary</b></p>		<p>Start at pin 10, wind 8 turns of 1 wire Item [4] in 1 layer with tight tension. Terminate at pin 9.</p>
<p><b>Insulation layer</b></p>		<p>Place 1 layers of tape Item [6] for insulation.</p>

<p><b>Termination</b></p>		<p>Terminate the CV1 windings at pin number 3.</p>
<p><b>Termination</b></p>		<p>Terminate the CV2/CV3 winding at pin number 5.</p>
<p><b>Termination</b></p>		<p>Terminate primary bias winding at pin number 7.</p>
<p><b>Insulation</b></p>		<p>Place 2 layers of tape Item [6] for insulation.</p>

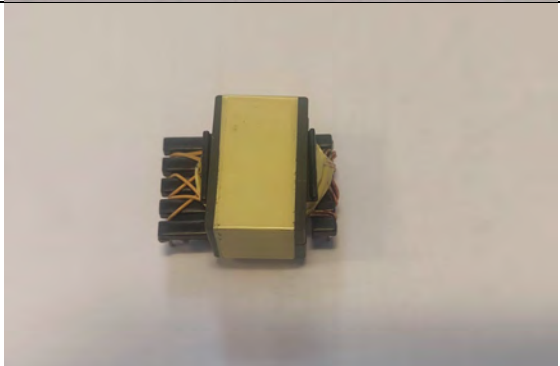
<p><b>Insert core</b></p>		<p>Gap core to achieve 188<math>\mu</math>H. Tape core tightly together.</p>
		<p>Cover with 1 layer of tape Item [8].  Varnish dip and cure Item [11]</p>

### 8.11 CMC Specification

#### 8.11.1 Electrical Diagram

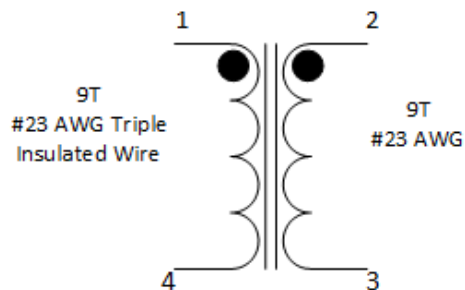

Figure 14 – Inductor Electrical Diagram.

#### 8.11.2 Electrical Specifications

<b>Inductance</b>	Pins 1-4 measured at 100 kHz, 0.4 RMS.	200 $\mu$ H $\pm$ 10%
<b>Primary Leakage Inductance</b>	Pins 1-4, with 2-3 shorted.	1 $\mu$ H

#### 8.11.3 List of Materials

Item	Description
[1]	Core: GL50 T 12X6X4-C, PI Part # 32-00315-00 BIPOLAR ELECTRONIC CO., LTD.
[2]	Magnet Wire: #23 AWG.
[3]	Triple Insulated wire #23 AWG.

#### 8.11.4 Illustration

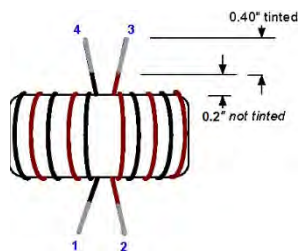

Note: Add Teflon sleeving for terminations.

### 8.12 CMC Winding Illustration

		<p>Start as pin 1 for Item [3] and pin 2 for Item [2].</p> <p>Wind together 9 turns on core Item [1].</p> <p>Mark end of Item [3] as pin 4 and end of Item [2] as pin 3.</p>
--	--	--

## 9 Performance

### 9.1 Current Limit Characteristic Curve

Current Limit Characteristic curve is verified in specific load points with calculating primary peak current at measured switching frequency points.

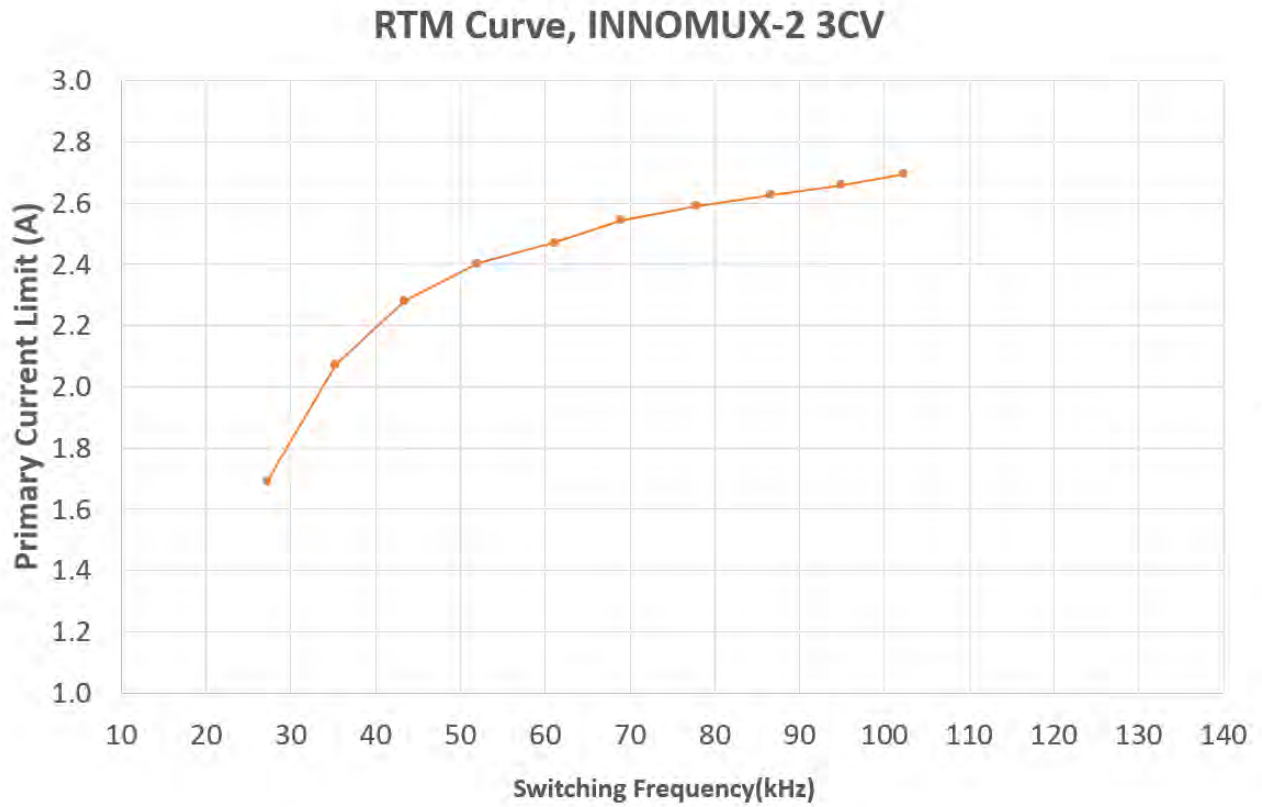

**Figure 15** – Primary Current (A) vs. SW frequency at Room Temperature.



### 9.2 Full Load Efficiency vs. Line Input Voltage

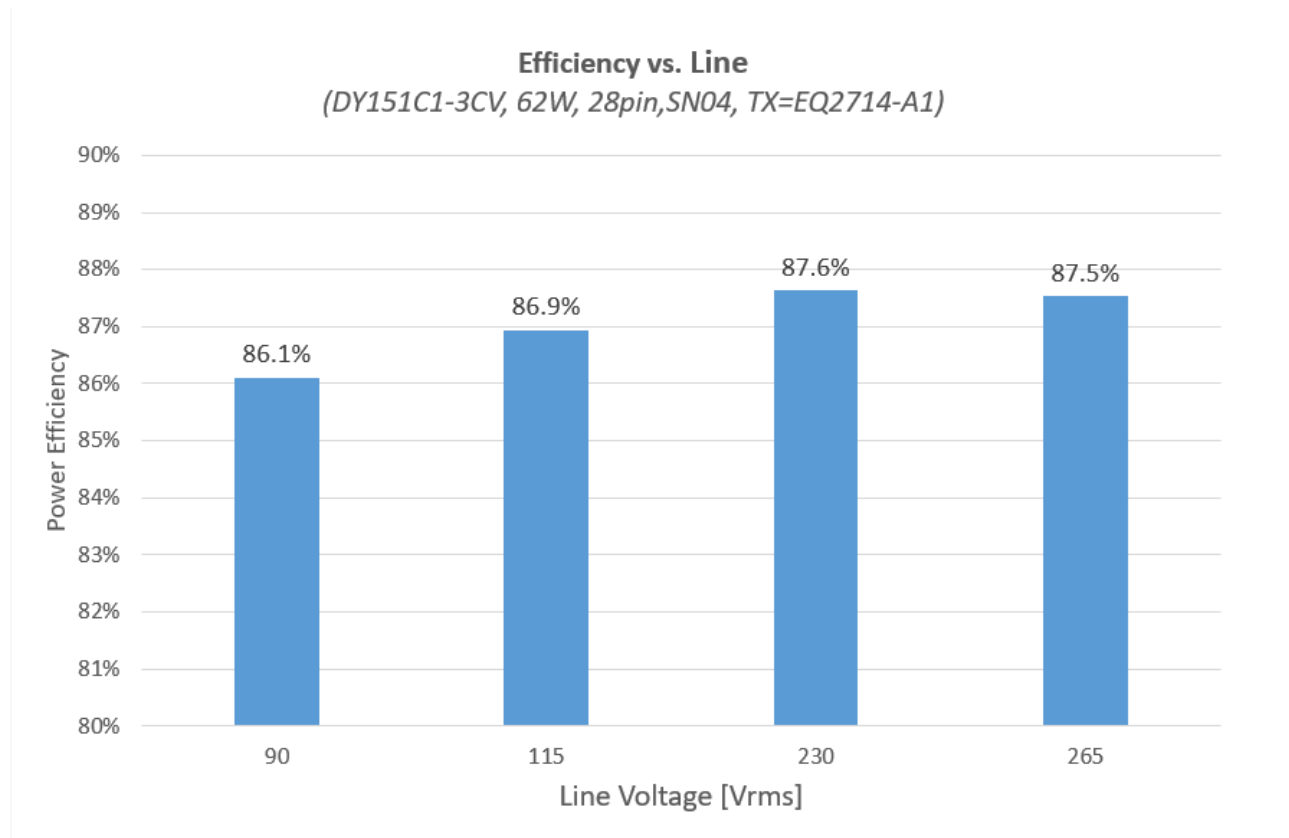
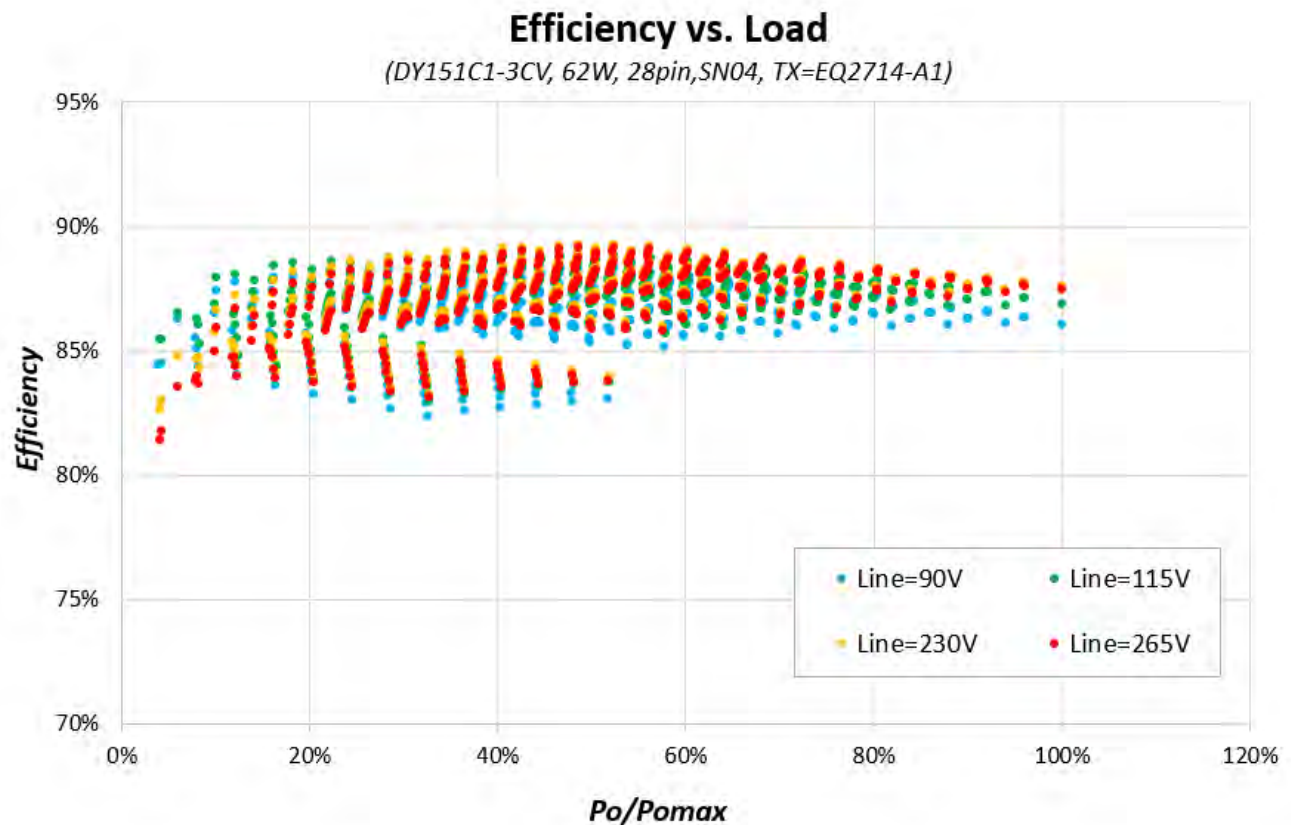

**Figure 16** – Full Power Efficiency vs. Line Voltage at Room Temperature.

### 9.3 Efficiency vs. Load

The efficiency vs. load measurements is shown below. These were obtained for all combinations of:

- All (nominal) line voltages (90 V, 115 V, 230 V, 265 V)
- CV1, CV2 and CV3 have total over thousand test points (load combinations) for the efficiency result.



**Figure 17** – Efficiency vs. Load for all line and  $V_{LED}$  variations, Room Temperature.

### 9.4 Output Load Regulation

The output-voltage regulation error was measured for all CV outputs

- The current at CV1 output was increased from 0% to 100% of its rating in 8 steps
- The current at CV2 output was increased from 0% to 100% of its rating in 5 steps
- The current at CV3 output was increased from 12% to 100% of its rating in 7 steps
- all (nominal) line voltages

The load regulation errors for the CV outputs are shown below.

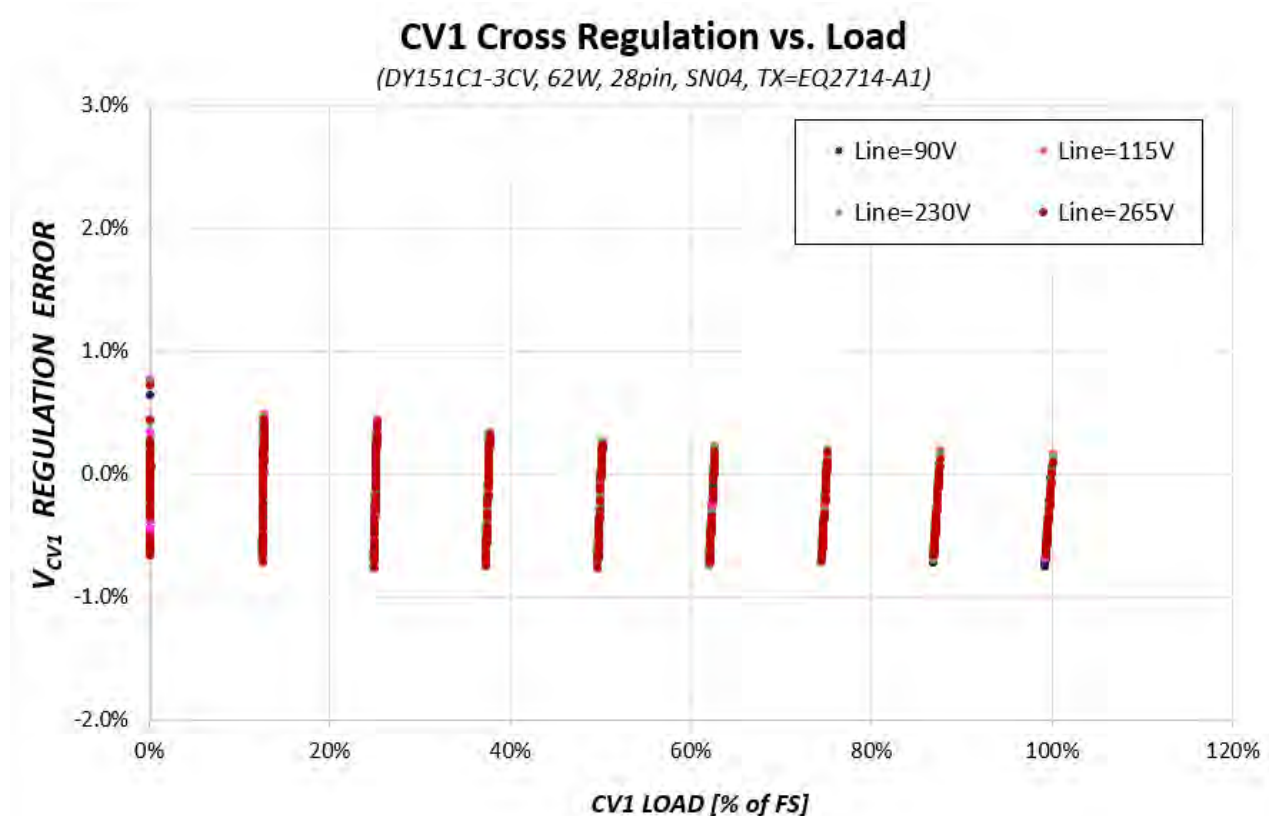

**Figure 18** – VCV1 Output Error vs. Percentage Load, at Room Temperature.

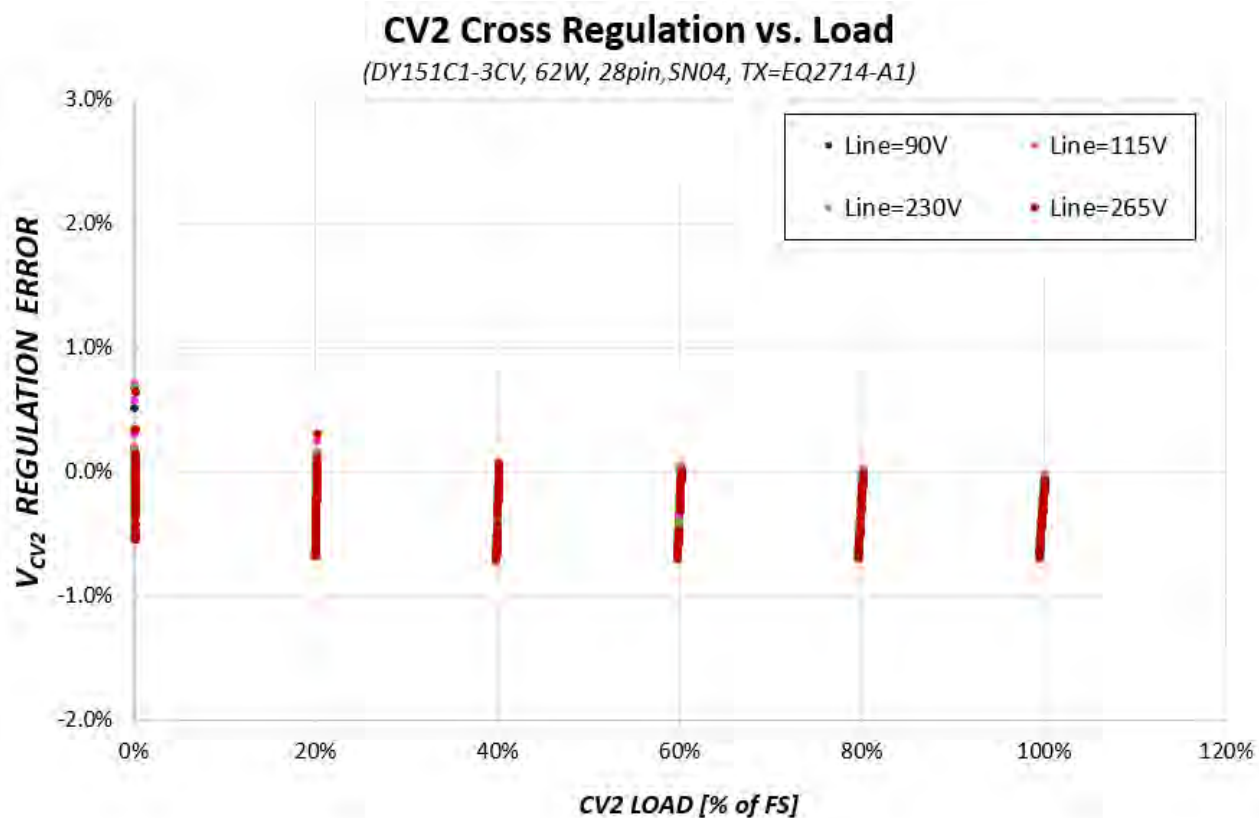

**Figure 19** – VCV2 Output Error vs. Percentage Load, at Room Temperature.

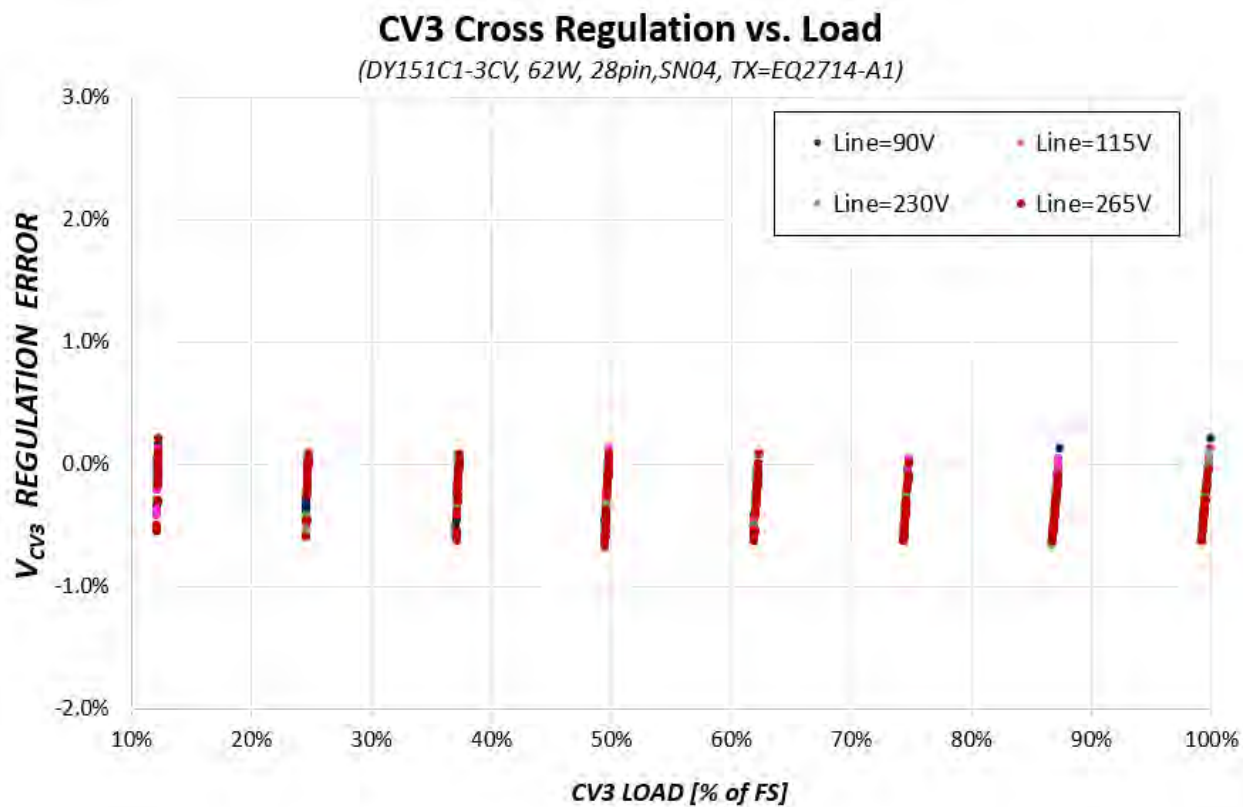

**Figure 20** – VCV3 Output Error vs. Percentage Load, at Room Temperature.

### 9.5 Standby Input Power

The converter standby power was measured for all (nominal) line voltages; with CV2 and CV3 no-load and for 0 mW ~ 250 mW load on the CV1 output. The results are shown in the Figure below.

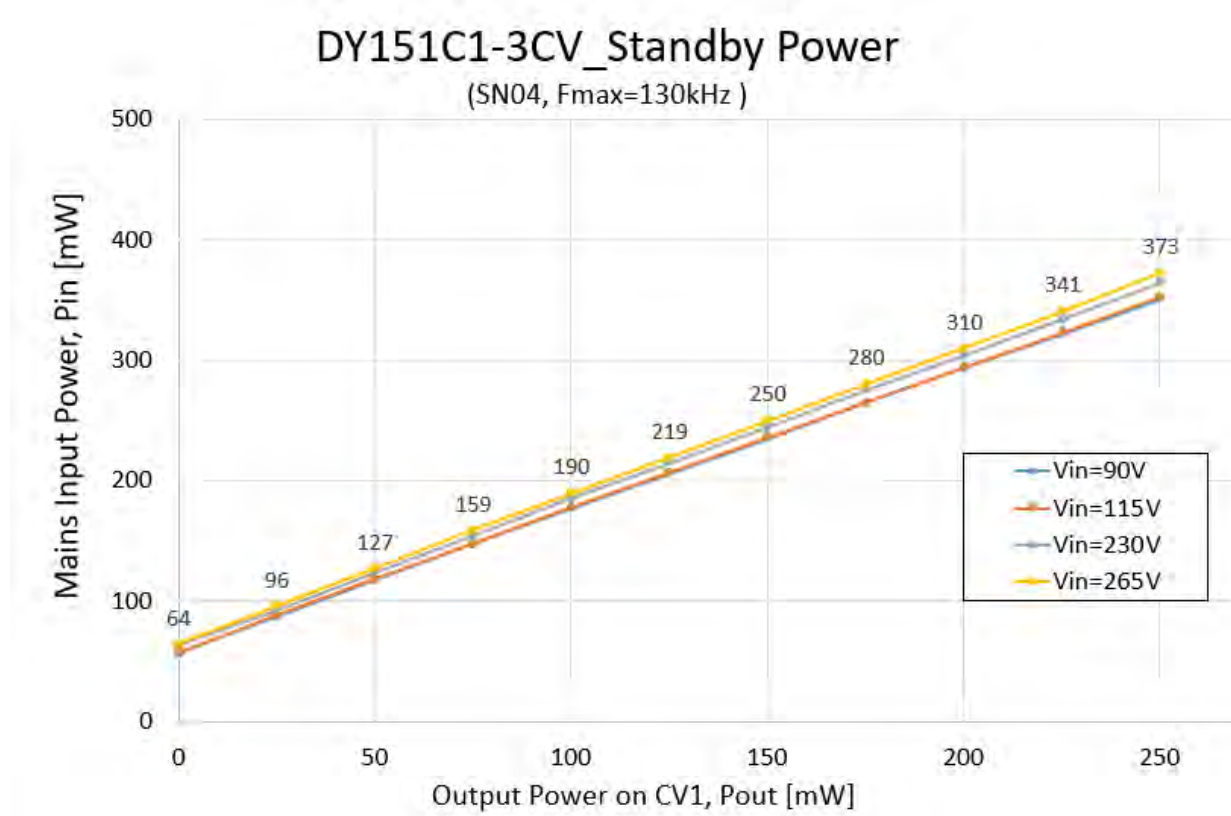
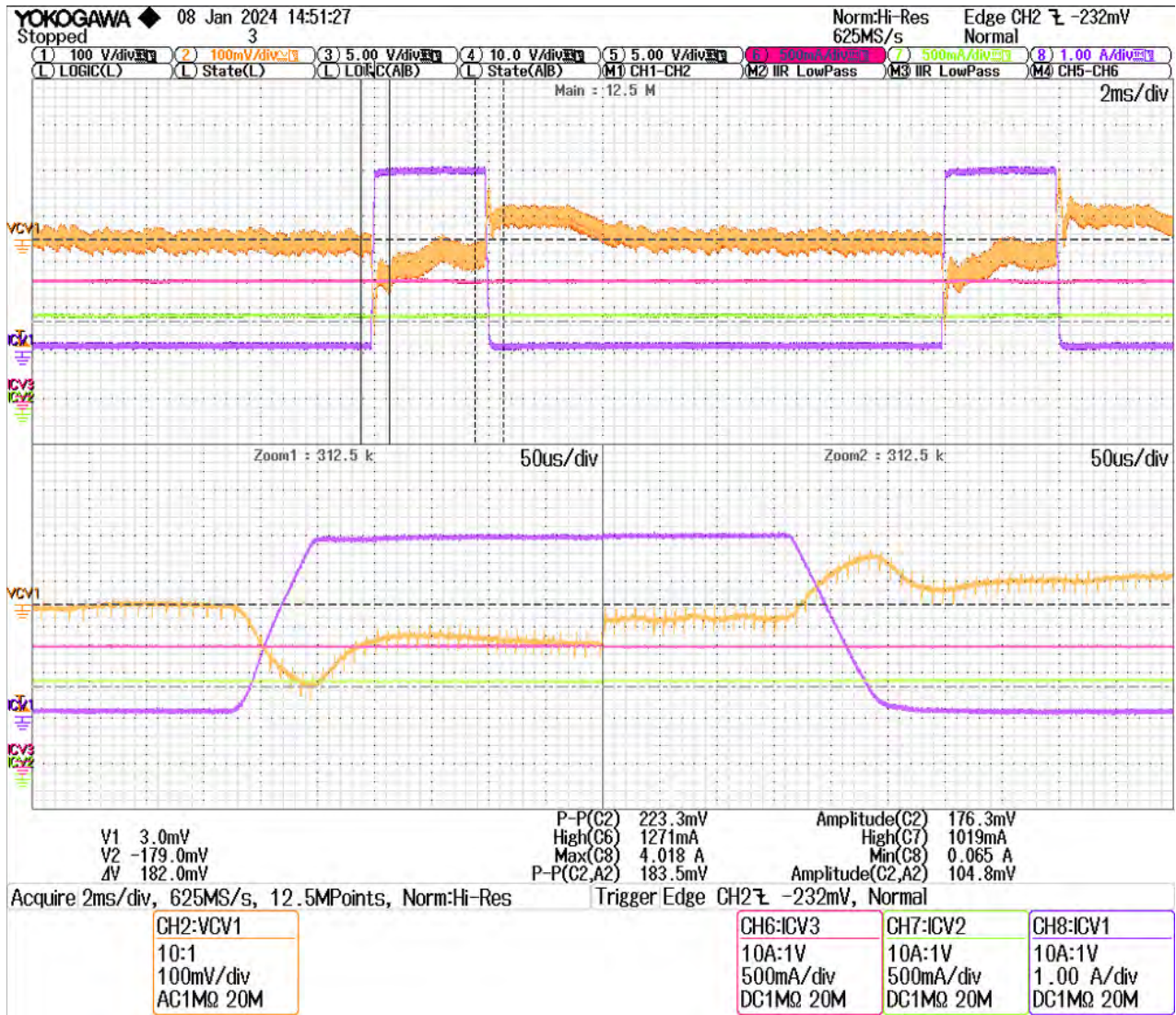

Figure 21 – Standby Power Consumption vs. Line Voltage, Room Temperature.

### 9.6 CV Load Transient Response

CV output voltages are measured at load transient from 0.05 A to 4 A for CV1, 0 A to 1 A for CV2, 0 A to 1.25 A for CV3. Measurement has been done at 90 VAC and 265 VAC with full load on other channels while the one supplied with load step and no-load on other channels when the one supplied with load step. In all cases less than 5% voltage drop observed on CV outputs.

Bandwidth of the channels are 20 MHz.



**Figure 22** – CV1 (5 V) Output - Load Transient Under Full Load on CV2 and CV3 at 90 VAC.  
 $I_{CV1} = 0.05 \text{ A} - 4 \text{ A}$ ; Undershoot 223 mV, 4.46%; Overshoot = 184 mV, 3.68%  
 CH2: V<sub>CV1</sub>, Ch6: I<sub>CV3</sub>, Ch7: I<sub>CV2</sub>, CH8: I<sub>CV1</sub>

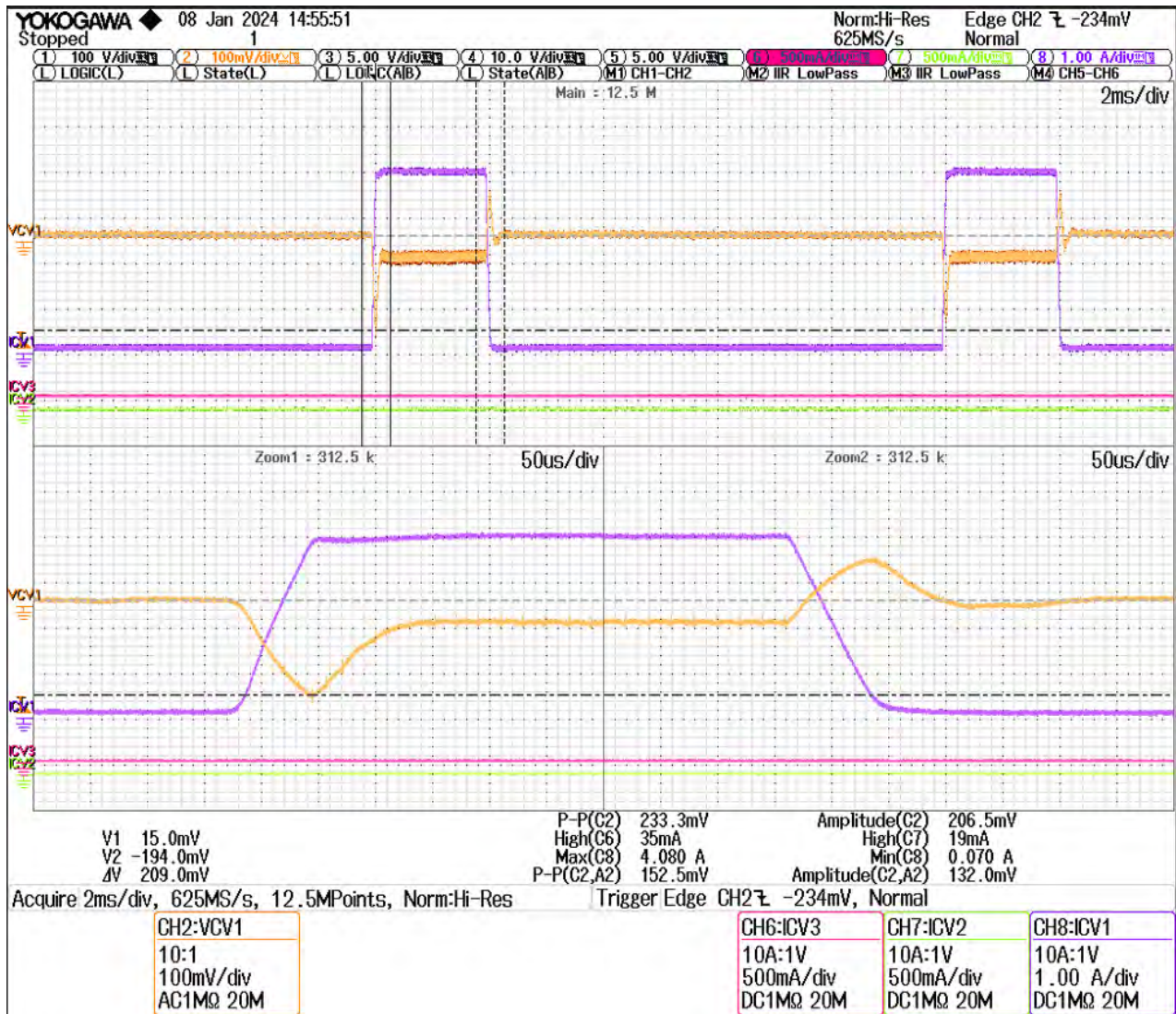

**Figure 23** – CV1 (5 V) Output - Load Transient Under No-Load on CV2 and CV3 at 90 VAC.

$I_{CV1}$  = 0.05 A – 4 A; Undershoot 233 mV, 4.66%; Overshoot = 152 mV, 3.04%

CH2: V<sub>CV1</sub>, Ch6: I<sub>CV3</sub>, Ch7: I<sub>CV2</sub>, CH8: I<sub>CV1</sub>





**Figure 24 – CV1 (5 V) Output - Load Transient Under Full Load on CV2 and CV3 at 265 VAC.**  
 $I_{CV1} = 0.05 \text{ A} - 4 \text{ A}$ ; Undershoot 222 mV, 4.44%; Overshoot = 230 mV, 4.6%  
 CH2:  $V_{CV1}$ , Ch6:  $I_{CV3}$ , Ch7:  $I_{CV2}$ , CH8:  $I_{CV1}$

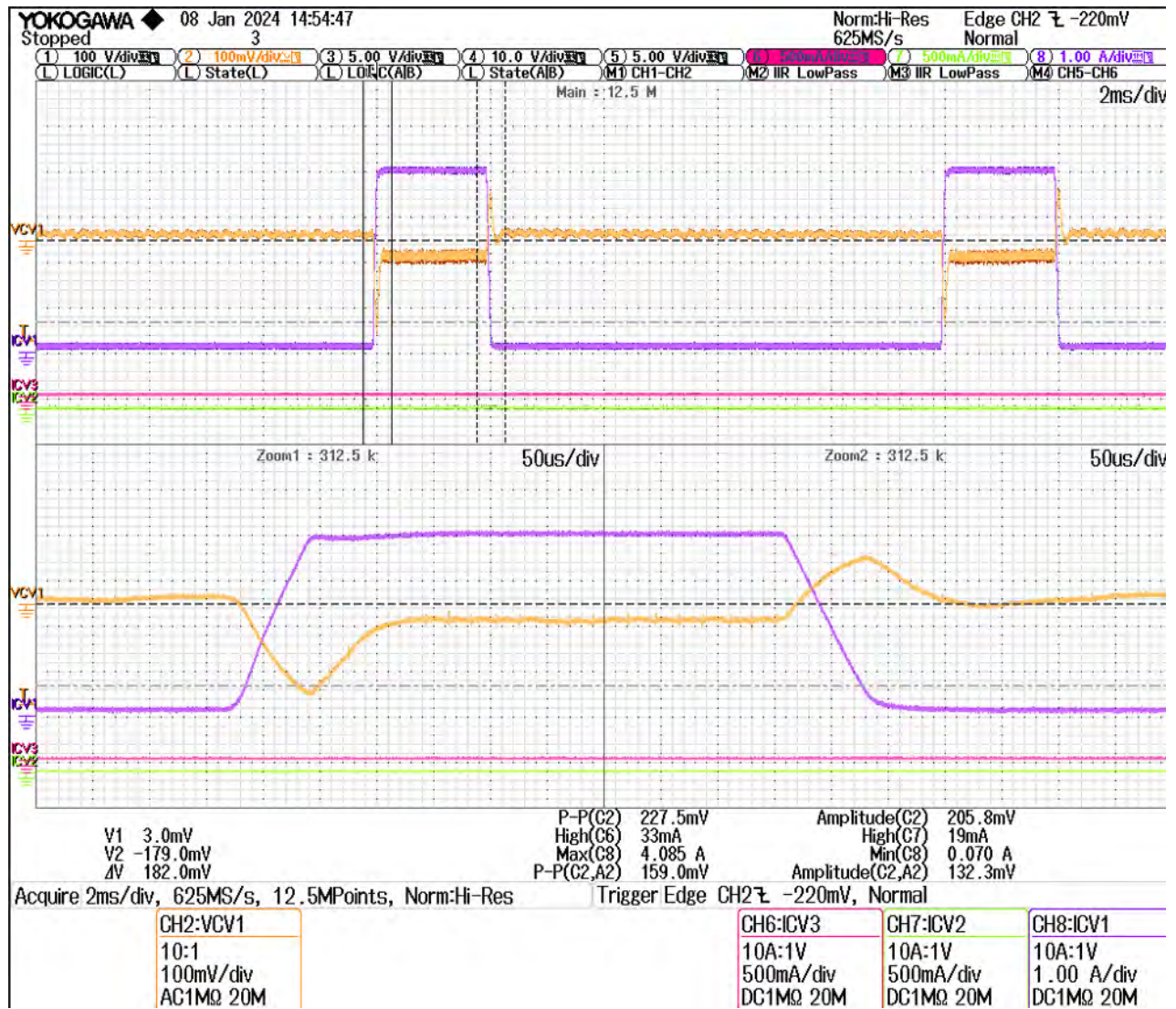

**Figure 25 – CV1 (5 V) Output - Load Transient Under No-Load on CV2 and CV3 at 265 VAC.**

$I_{CV1}$  = 0.05 A - 4 A; Undershoot 228 mV, 4.56%; Overshoot = 159 mV, 3.18%

CH2:  $V_{CV1}$ , CH6:  $I_{CV3}$ , CH7:  $I_{CV2}$ , CH8:  $I_{CV1}$



**Figure 26 – CV2 (12 V) Output - Load Transient Under Full Load on CV1 and CV3 at 90 VAC.**  
 $I_{CV2} = 0 \text{ A} - 1 \text{ A}$ ; Undershoot 214 mV, 1.78%; Overshoot = 185 mV, 1.54%  
 CH2:  $V_{CV2}$ , Ch6:  $I_{CV3}$ , Ch7:  $I_{CV2}$ , CH8:  $I_{CV1}$

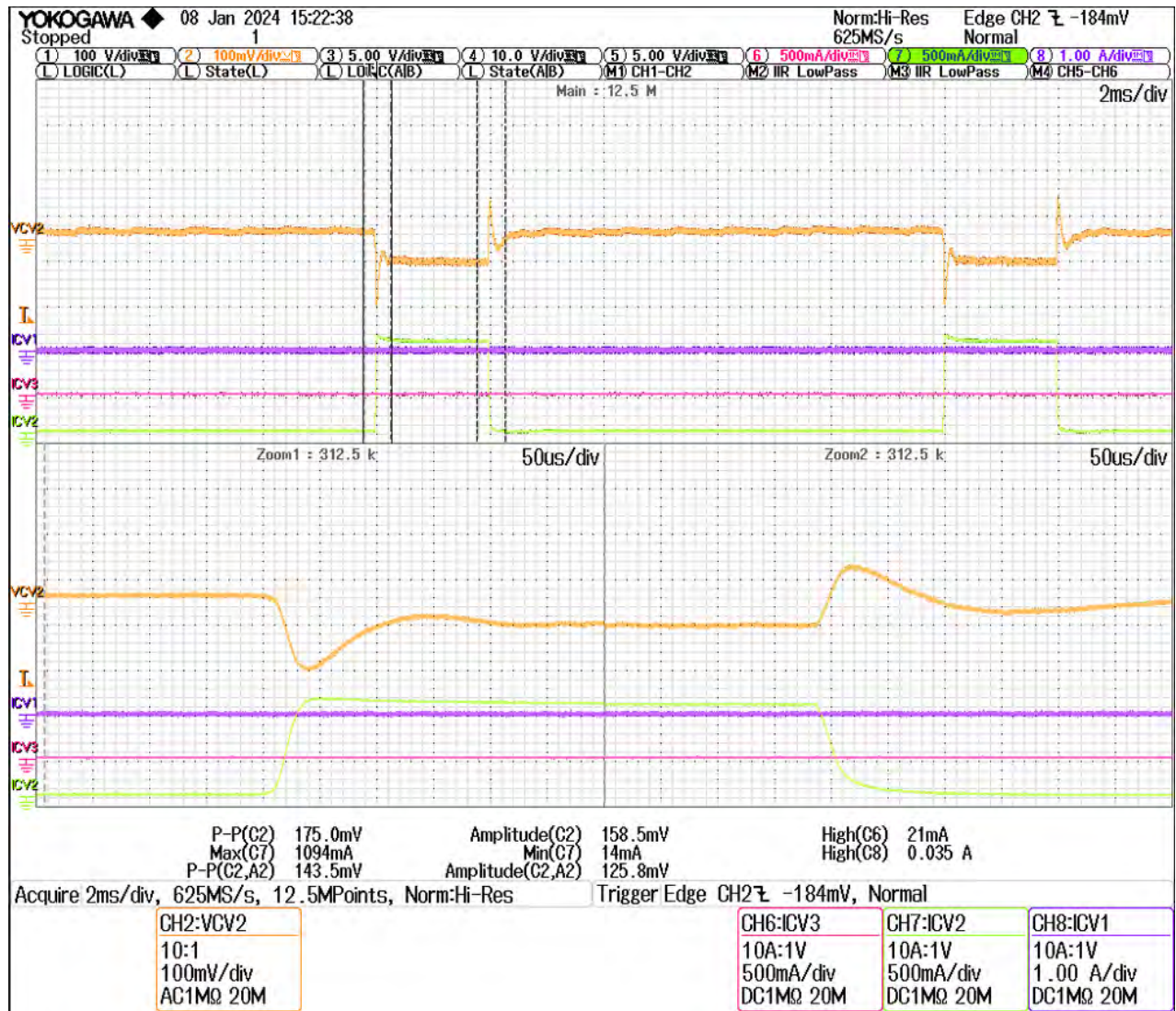

**Figure 27** – CV2 (12 V) Output - Load Transient Under No-Load on CV1 and CV3 at 90 VAC.

$I_{CV2} = 0\text{ A} - 1\text{ A}$ ; Undershoot 175 mV, 1.46%; Overshoot = 144mV, 1.2%

CH2: VCV2, Ch6: Icv3, Ch7: Icv2, CH8: Icv1

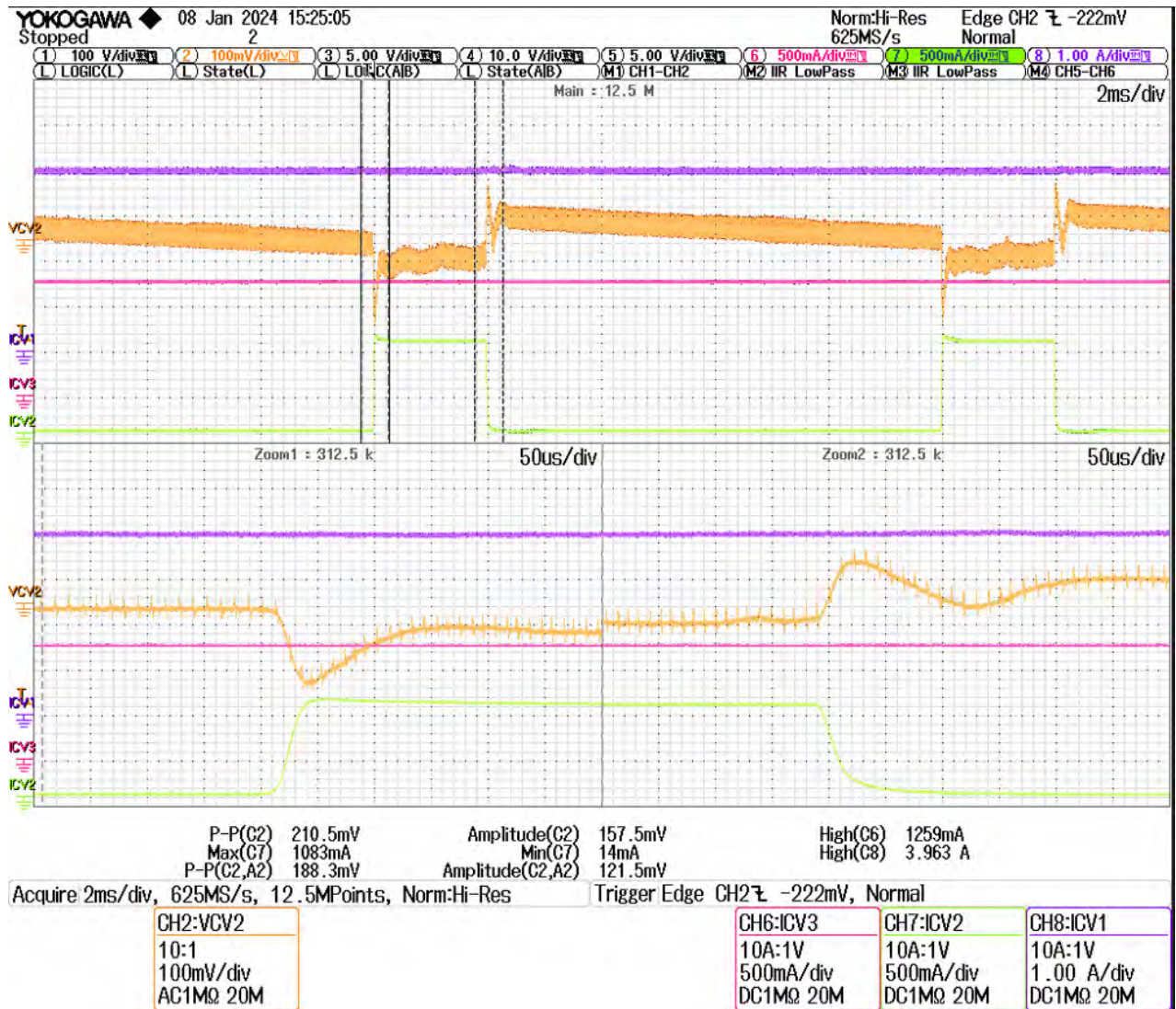

**Figure 28 – CV2 (12 V) Output - Load Transient Under Full Load on CV1 and CV3 at 265 VAC.**

$I_{CV2} = 0\text{ A} - 1\text{ A}$ ; Undershoot 211 mV, 1.76%; Overshoot = 188 mV, 1.57%

CH2:  $V_{CV2}$ , Ch6:  $I_{CV3}$ , Ch7:  $I_{CV2}$ , CH8:  $I_{CV1}$



**Figure 29** – CV2 (12 V) Output - Load Transient Under No-Load on CV1 and CV3 at 265 VAC.

$I_{CV2} = 0 \text{ A} - 1 \text{ A}$ ; Undershoot 177 mV, 1.47%; Overshoot = 146 mV, 1.22%

CH2:  $V_{CV2}$ , Ch6:  $I_{CV3}$ , Ch7:  $I_{CV2}$ , CH8:  $I_{CV1}$

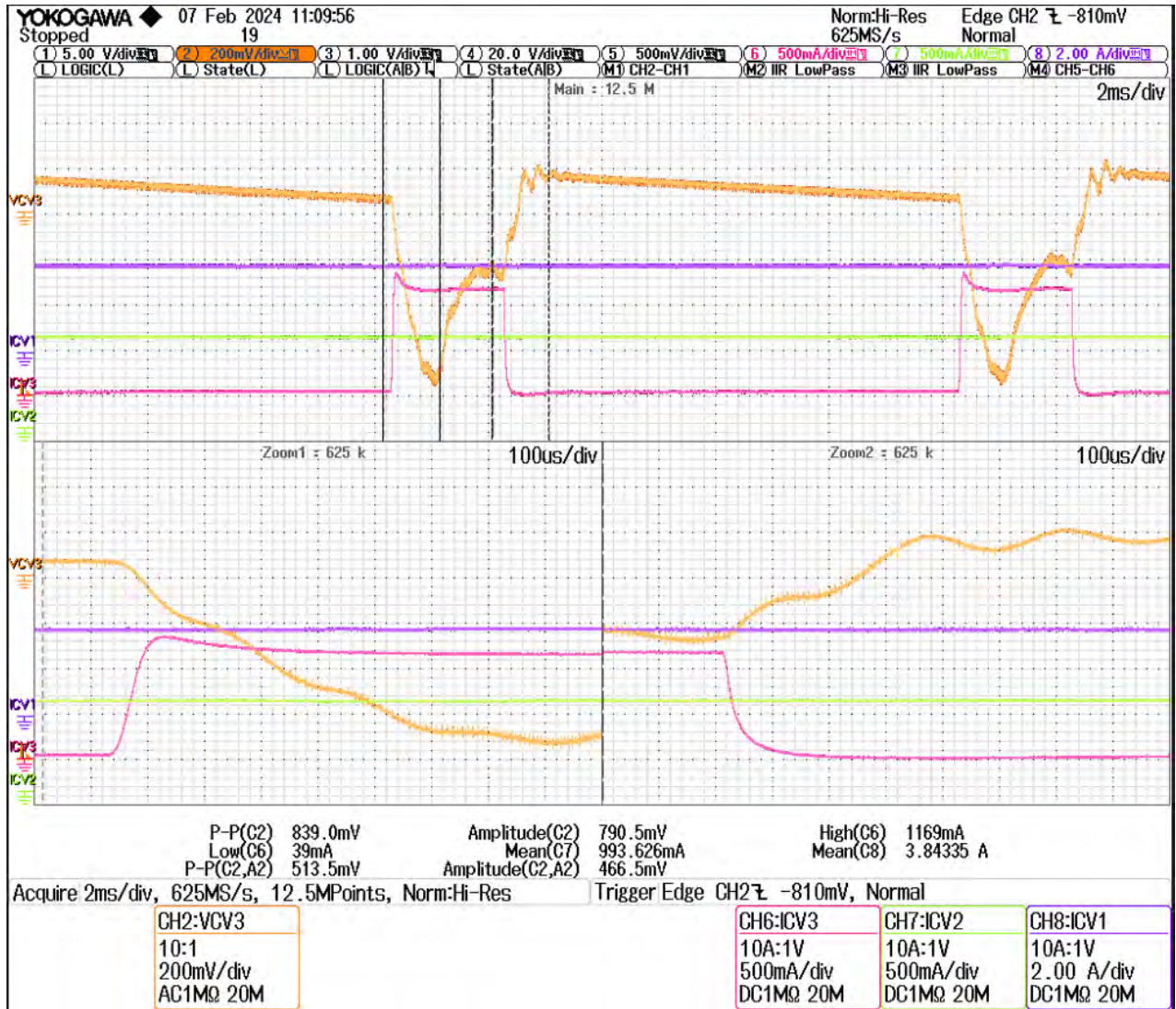

**Figure 30 – CV3 (24 V) Output - Load Transient Under Full Load on CV1 and CV2 at 90 VAC.**

$I_{CV2}=0.1A - 1.25 A$ ; Undershoot 839 mV, 3.49%; Overshoot = 514 mV, 2.14%

CH2:  $V_{CV3}$ , Ch6:  $I_{CV3}$ , Ch7:  $I_{CV2}$ , CH8:  $I_{CV1}$

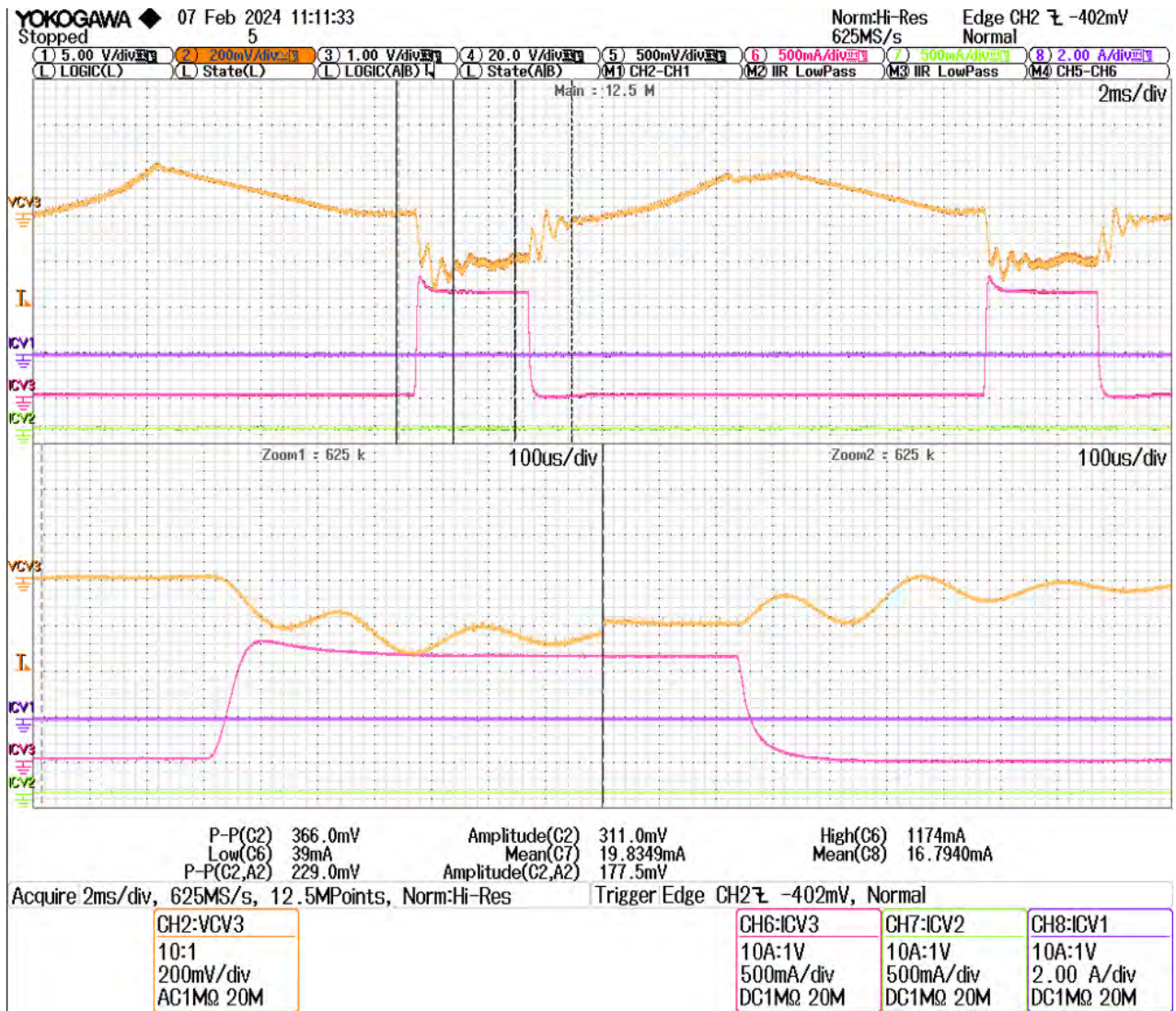

**Figure 31 – CV3 (24 V) Output - Load Transient Under No-Load on CV1 and CV2 at 90 VAC.**

$I_{CV2} = 0.1 \text{ A} - 1.25 \text{ A}$ ; Undershoot 366 mV, 1.53%; Overshoot = 229 mV, 0.96%

CH2: V<sub>CV3</sub>, CH6: I<sub>CV3</sub>, CH7: I<sub>CV2</sub>, CH8: I<sub>CV1</sub>

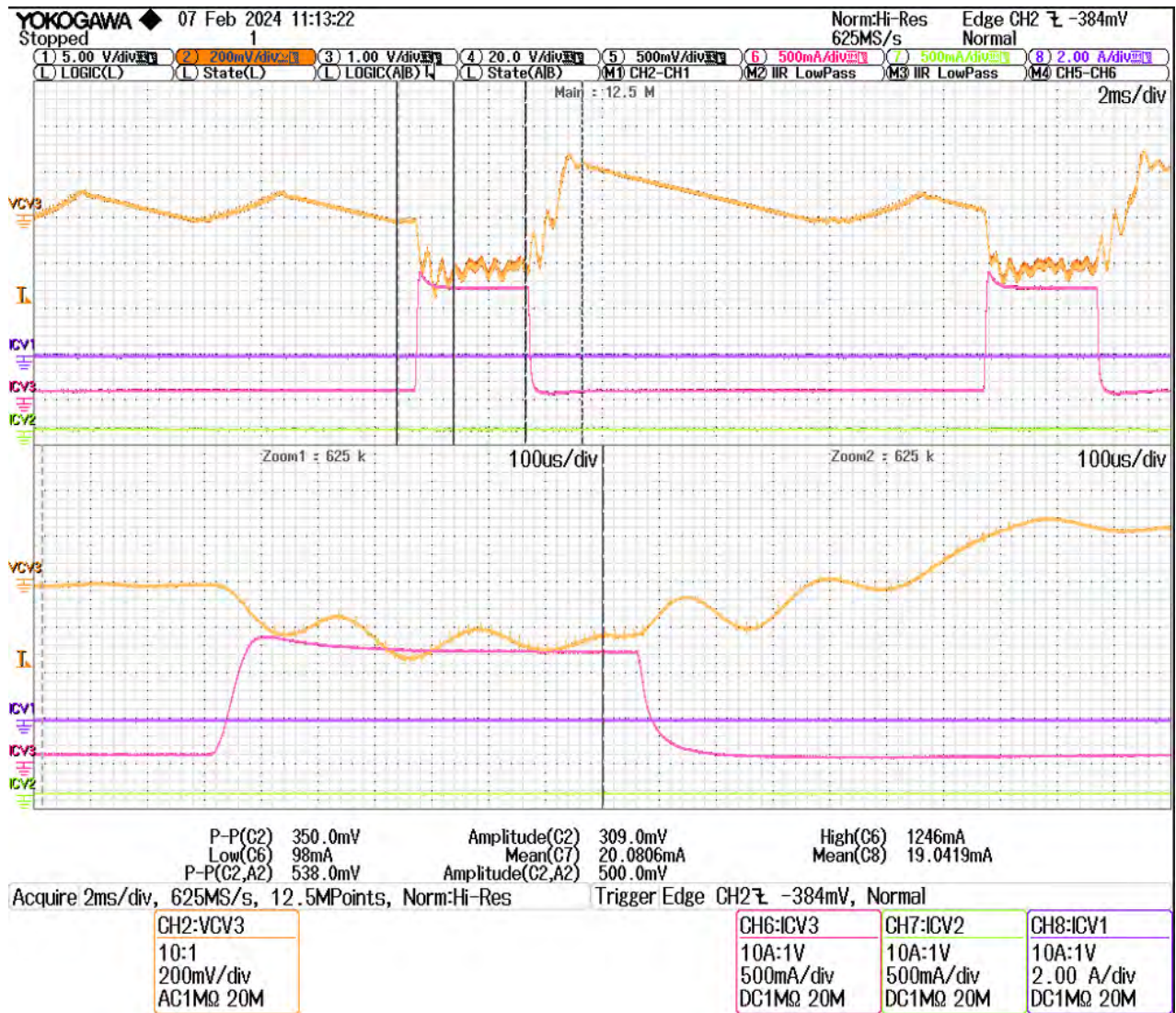



**Figure 32 – CV3 (24 V) Output - Load Transient Under Full Load on CV1 and CV2 at 265 VAC.**

$I_{CV2} = 0.1 \text{ A} - 1.25 \text{ A}$ ; Undershoot 846 mV, 3.5%; Overshoot = 563 mV, 2.35%

CH2:  $V_{CV3}$ , CH6:  $I_{CV3}$ , CH7:  $I_{CV2}$ , CH8:  $I_{CV1}$



**Figure 33 – CV3 (24 V) Output - Load Transient Under No-Load on CV1 and CV2 at 265 VAC.**

$I_{cv2} = 0.1 \text{ A} - 1.25 \text{ A}$ ; Undershoot 350 mV, 1.46%; Overshoot = 538 mV, 2.24%

CH2:  $V_{CV3}$  Ch6:  $I_{cv3}$ , Ch7:  $I_{cv2}$ , CH8:  $I_{cv1}$

### 9.7 Switching Waveforms

#### 9.7.1 Primary Switch Maximum Voltage

Voltages on the primary FET have been measured at 265 VAC and 90 VAC under full load condition. Channel bandwidth is 200 MHz.



Figure 34 – Primary Switch Voltage Under Full Load at 265 VAC.

CH1:  $V_{DRAIN}$ , CH6:  $I_{CV3}$ , CH7:  $I_{CV2}$ , CH8:  $I_{CV1}$

Maximum D-S voltage across the primary switch is 602 V.

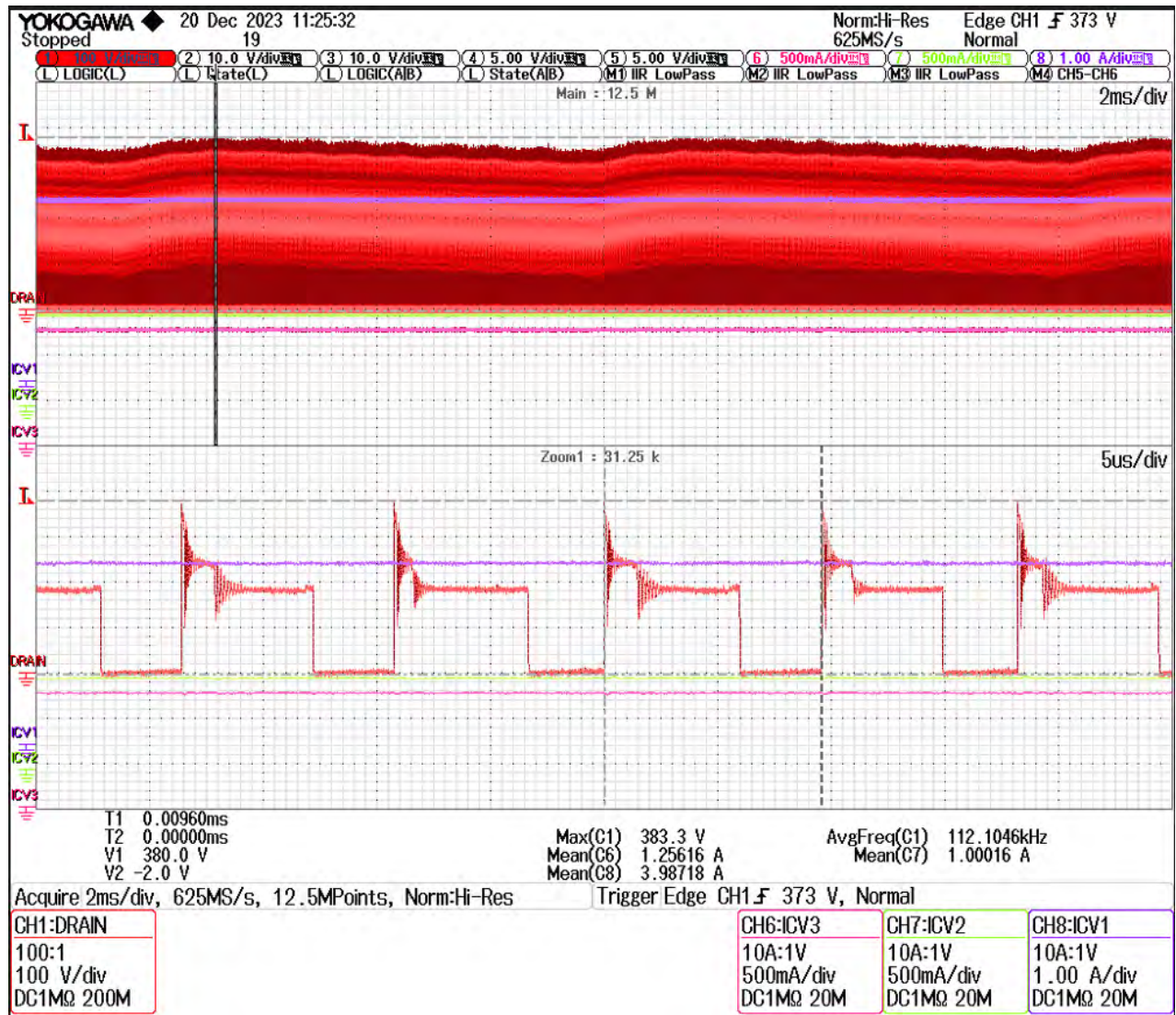

Figure 35 – Primary Switch Voltage Under Full Load at 90 VAC.

CH1:  $V_{DRAIN}$ , CH6:  $I_{CV3}$ , CH7:  $I_{CV2}$ , CH8:  $I_{CV1}$

Maximum D-S voltage across the primary switch is 383 V.

### 9.7.2 Primary Switching Frequency

The primary switching frequency of the converter varies depending on line and load conditions. It was measured under full load at minimum line input of 90 VAC. The maximum switching frequency occurs at the minimum DC input (115 kHz). CV1 channel has 4 A, CV2 has 1 A, CV3 has 1.25 A load currents.

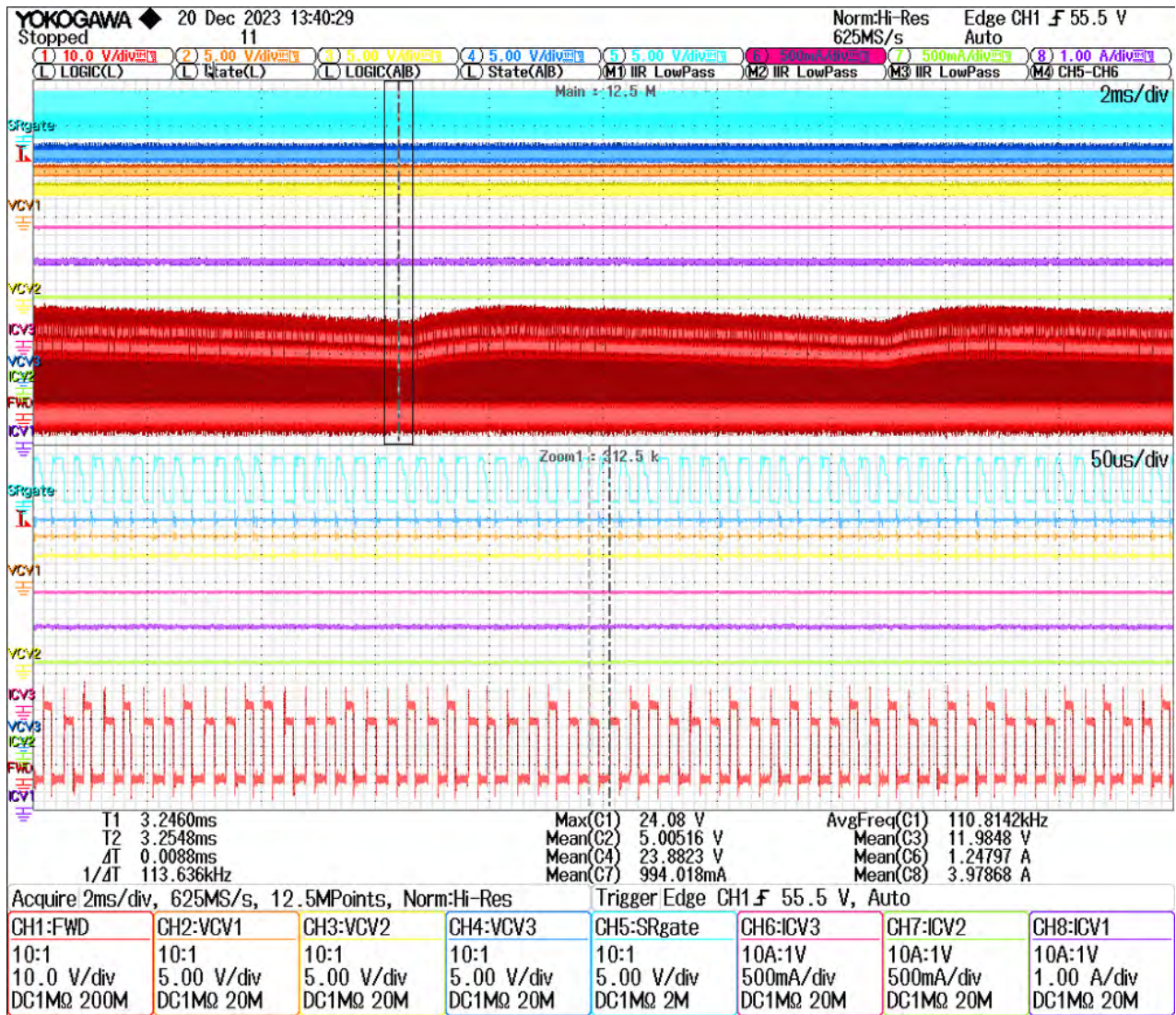

Figure 36 – Maximum Primary Switching Frequency (115 kHz).

9.7.3 Transformer Current Waveforms

CH4	ICV1_TX
CH5	ICV2_TX
CH6	ICV3_TX
CH7	IPR_SW
CH8	ISR

Scope Channel Allocation (This Section).

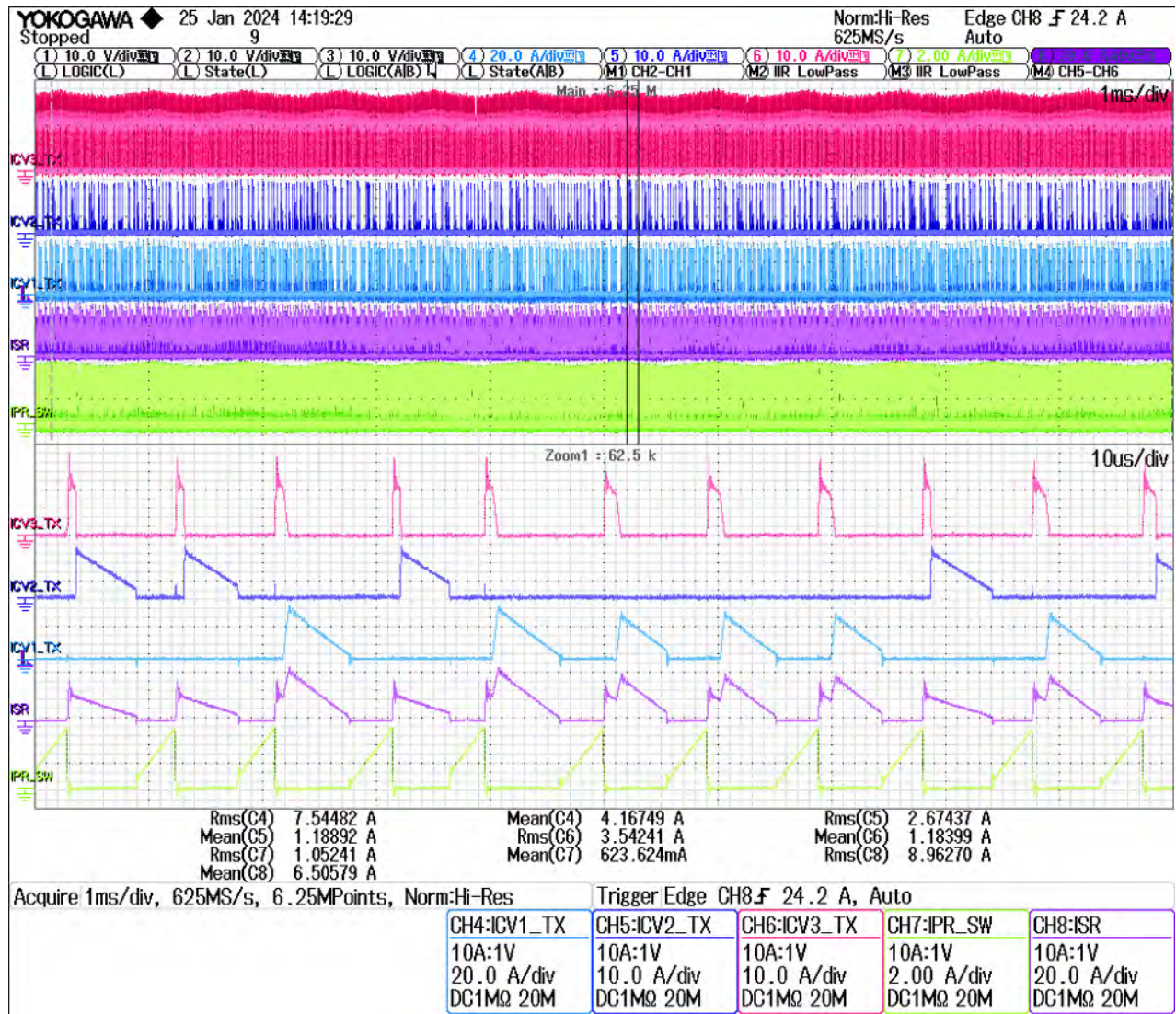

Figure 37 – Transformer Winding Currents at Minimum Input Voltage.

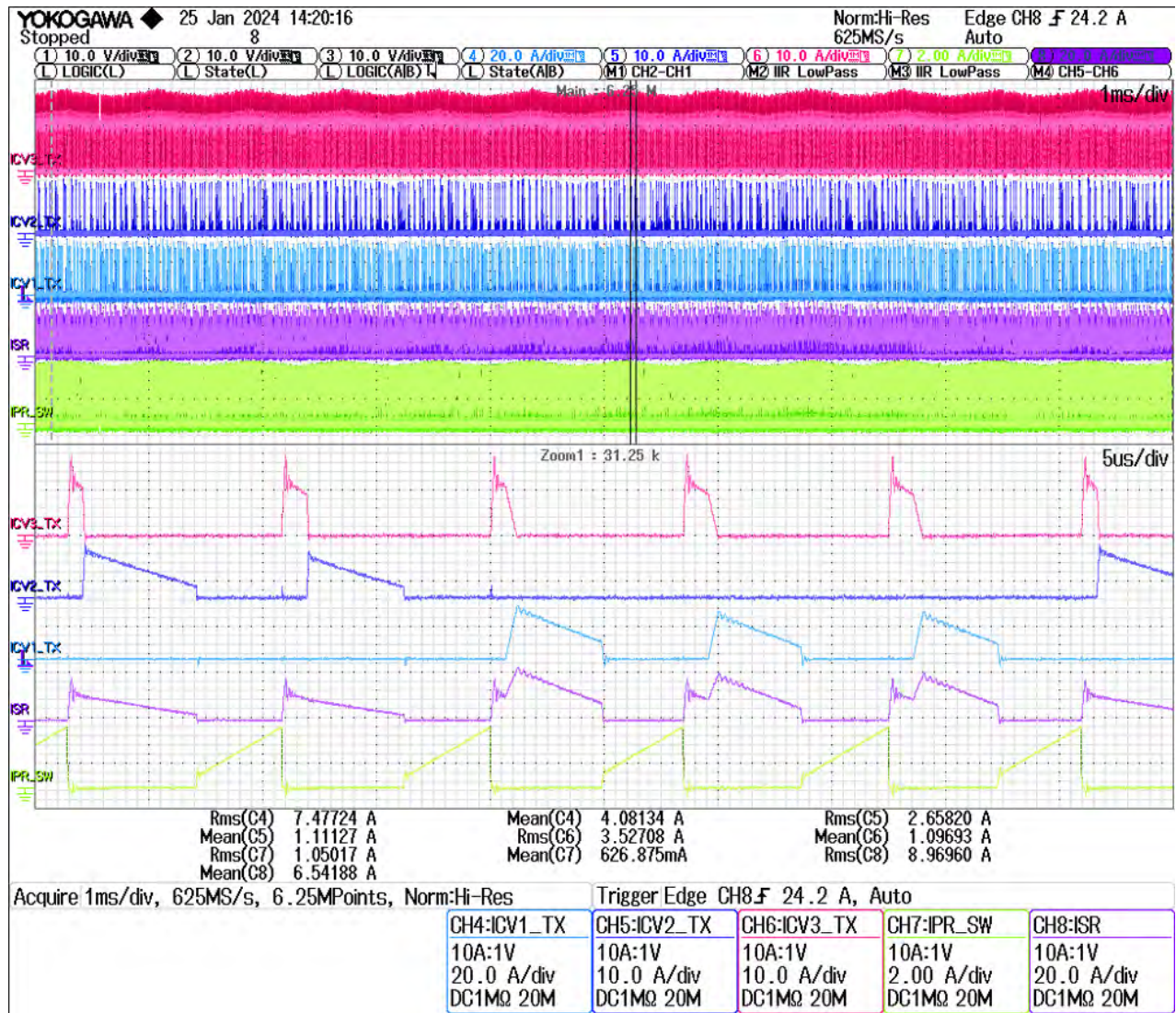

Figure 38 – Transformer Currents – Detailed View.

9.8 Start-Up

CH2	VCV1
CH3	VCV2
CH4	VCV3
CH5	BPS voltage
CH6	ICV3
CH7	ICV2
CH8	ICV1

Scope Channel Allocation (This Section).

9.8.1 Full Load Start-up

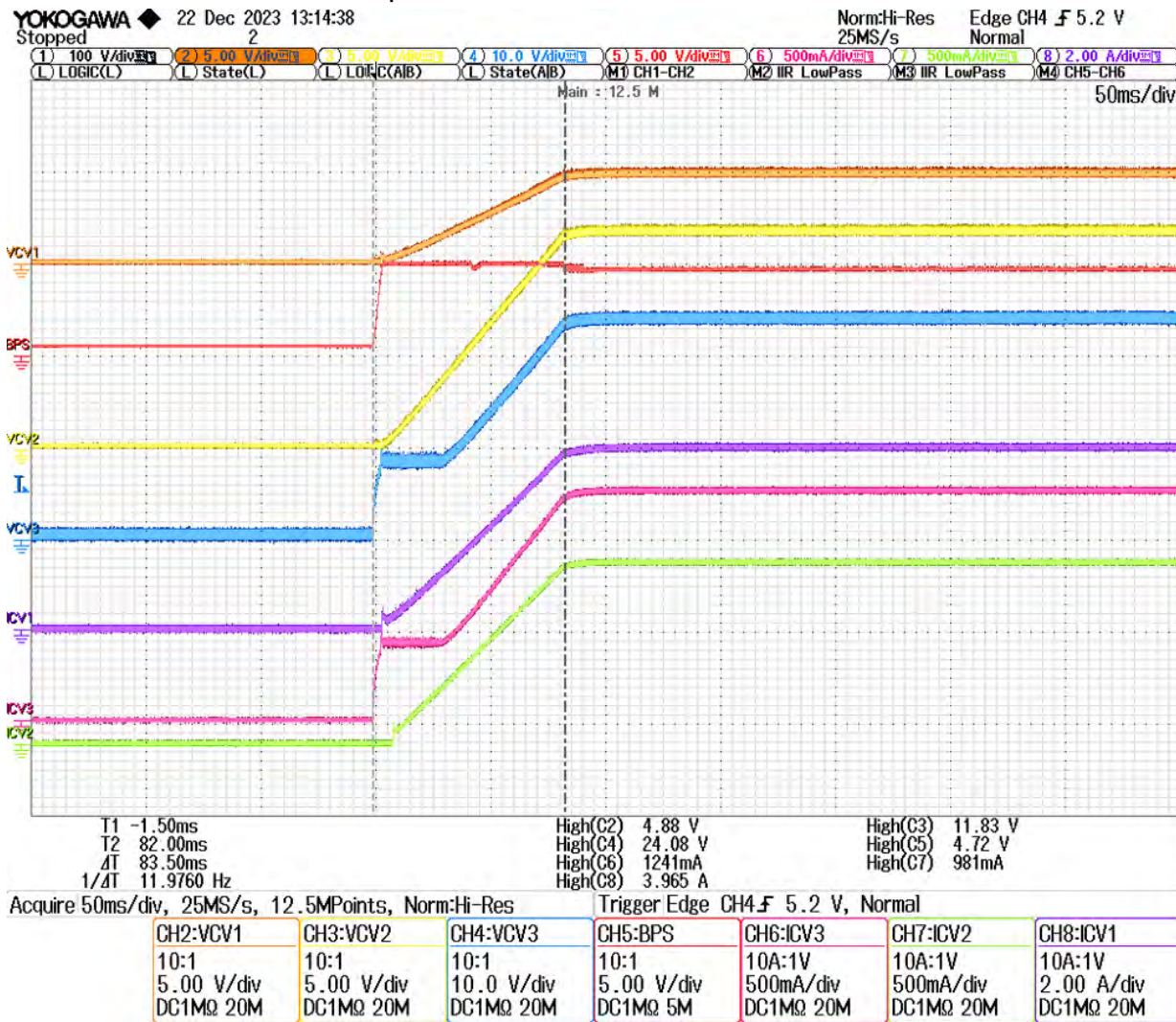

Figure 39 – Full Load Start-up. Line Input 90 VAC.



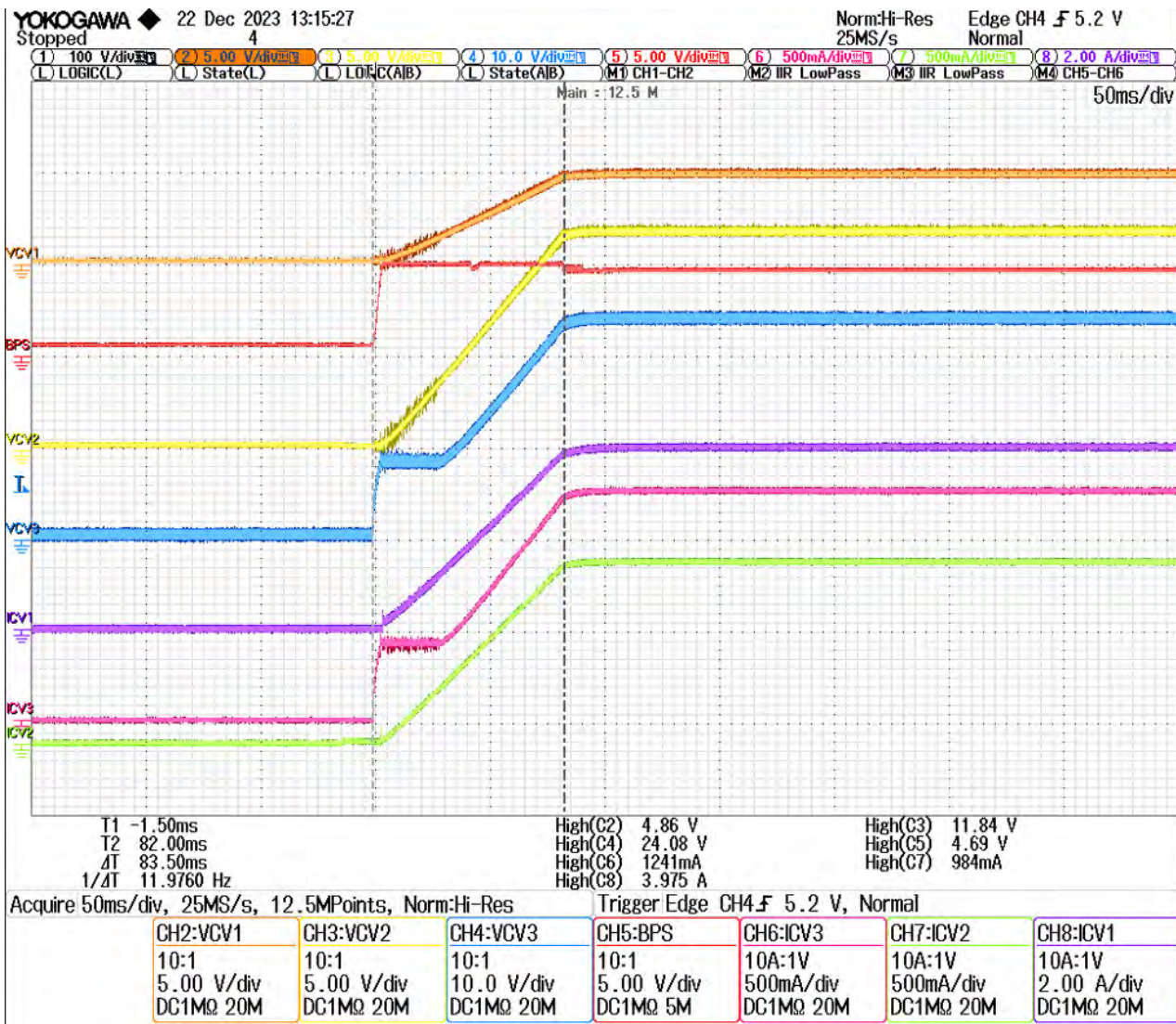

Figure 40 – Full Load Start-up. Line Input 265 VAC.

9.8.2 No-Load Start-up

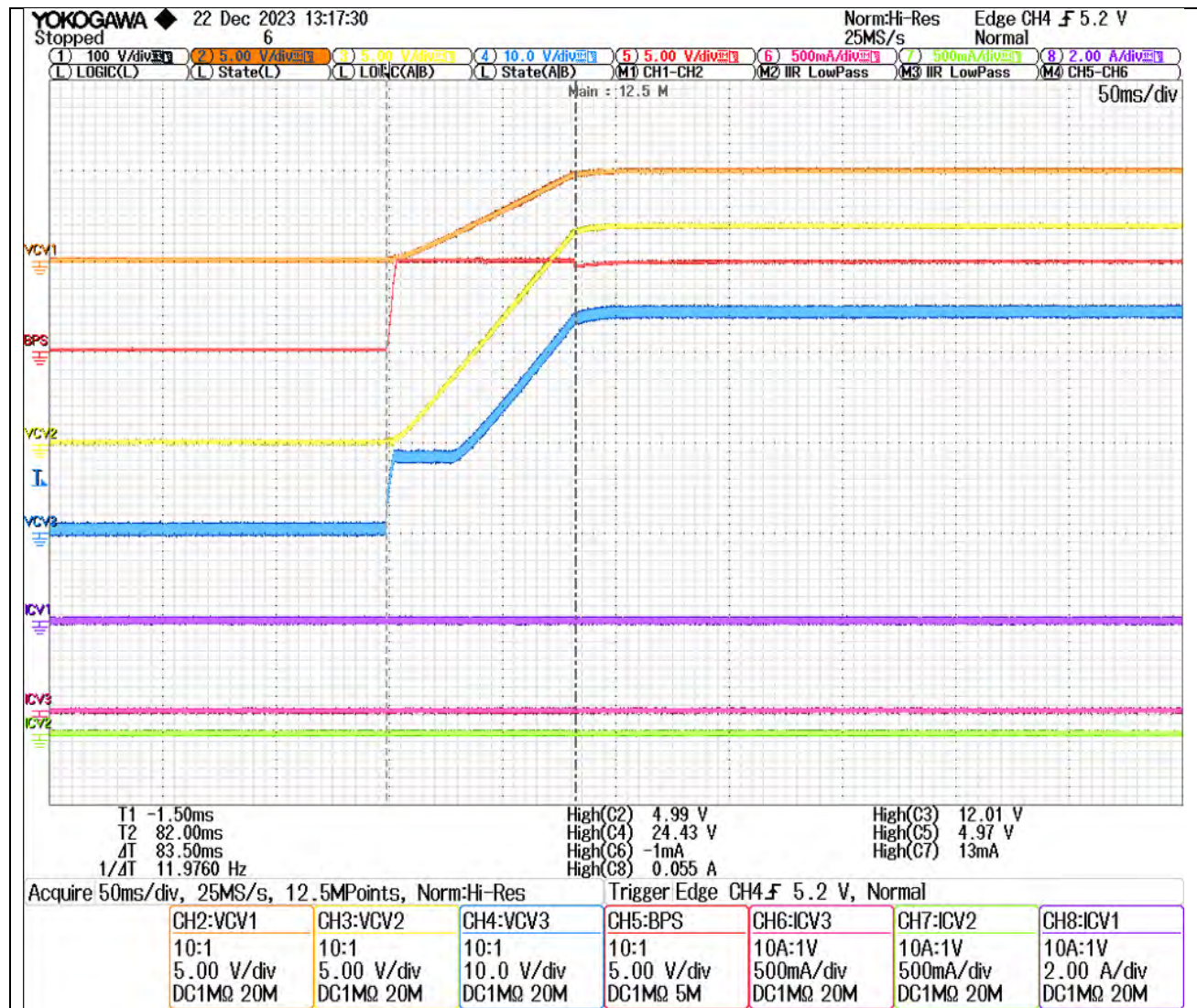

Figure 41 – No-load Start-up, Line Input 90 VAC.

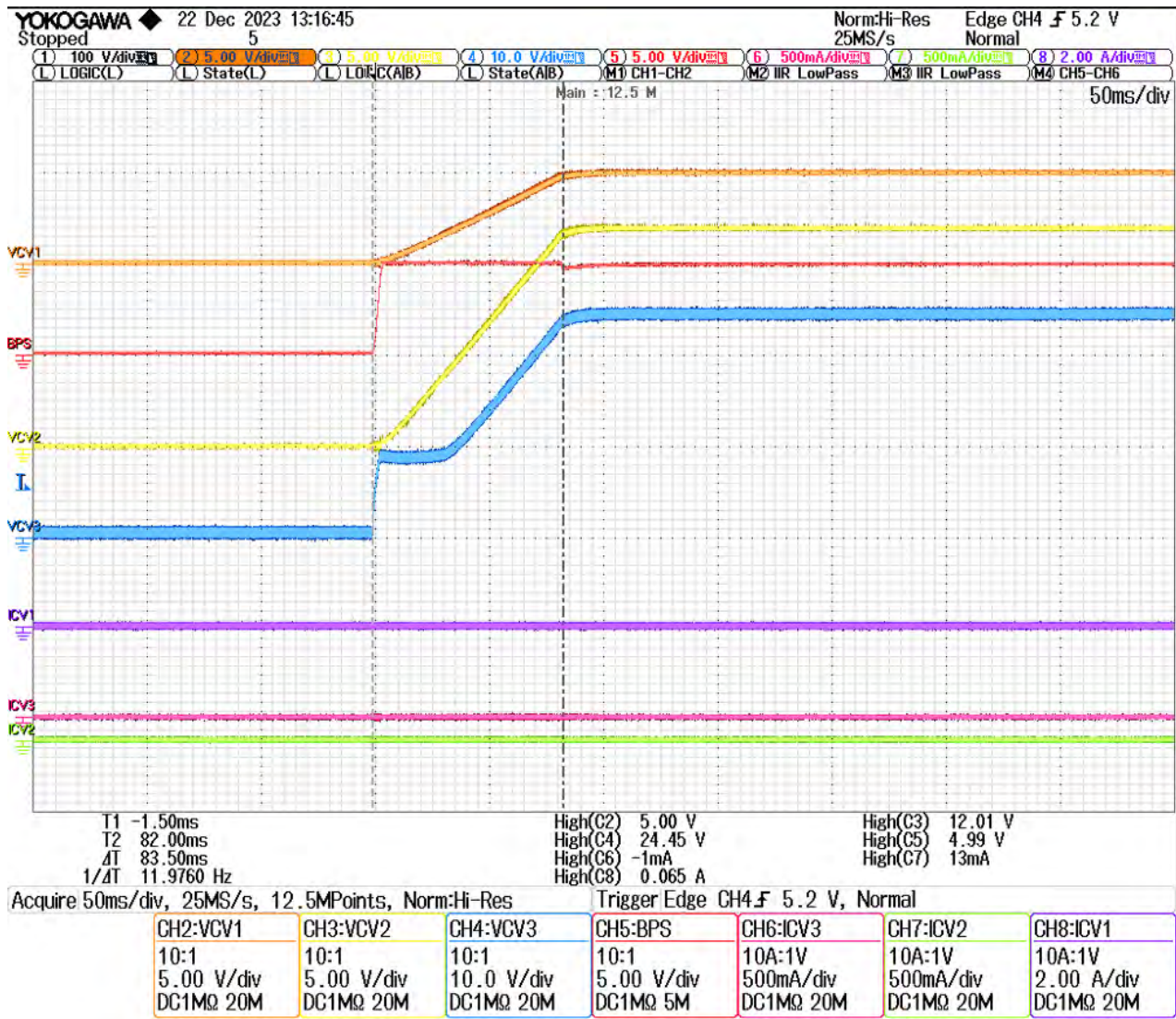

Figure 42 – No-load Start-up, Line Input 265 VAC.

### 9.8.3 Start-up Under CV Fault Conditions

CH1	FWD
CH2	VCV1
CH3	VCV2
CH4	CDR3
CH5	CDR1
CH6	ICV3
CH7	ICV2
CH8	ICV1

Scope Channel Allocation (This Section).

The converter was tested for start-up under two types of single fault conditions, namely:

- Short-circuit to GND at CV1 output
- Short-circuit to GND at CV2 output
- Short-circuit to GND at CV3 output
- Open circuit of feedbacks

In all cases, the converter protection prevented any permanent damage to its components. The line fuse F1 remained intact. The converter went into auto restart for the duration of the fault condition. It resumed normal operation after the fault condition was removed.

Details of the start-up behavior under those fault conditions are shown in Figure 43 to Figure 66

9.8.4 Protection Under Fault Conditions

CV's Full Load	Faults Before Start-up					
	CV1 Short to GND		CV2 Short to GND		CV3 Short to GND	
	90 V	265 V	90 V	265 V	90 V	265 V
Protection Definition	Protection Enabled	Protection Enabled	Protection Enabled	Protection Enabled	Protection Enabled	Protection Enabled

CV's No-Load	Faults Before Start-up					
	CV1 Short to GND		CV2 Short to GND		CV3 Short to GND	
	90 V	265 V	90 V	265 V	90 V	265 V
Protection Definition	Protection Enabled	Protection Enabled	Protection Enabled	Protection Enabled	Protection Enabled	Protection Enabled

CV's Full Load	Faults Before Start-up					
	CV1 FB Open		CV2 FB Open		CV3 FB Open	
	90 V	265 V	90 V	265 V	90 V	265 V
Protection Definition	Protection Enabled	Protection Enabled	Protection Enabled	Protection Enabled	Protection Enabled	Protection Enabled

CV's No-Load	Faults Before Start-up					
	CV1 FB Open		CV2 FB Open		CV3 FB Open	
	90 V	265 V	90 V	265 V	90 V	265 V
Protection Definition	Protection Enabled	Protection Enabled	Protection Enabled	Protection Enabled	Protection Enabled	Protection Enabled

9.8.4.1 Start-up Under CV Fault Conditions

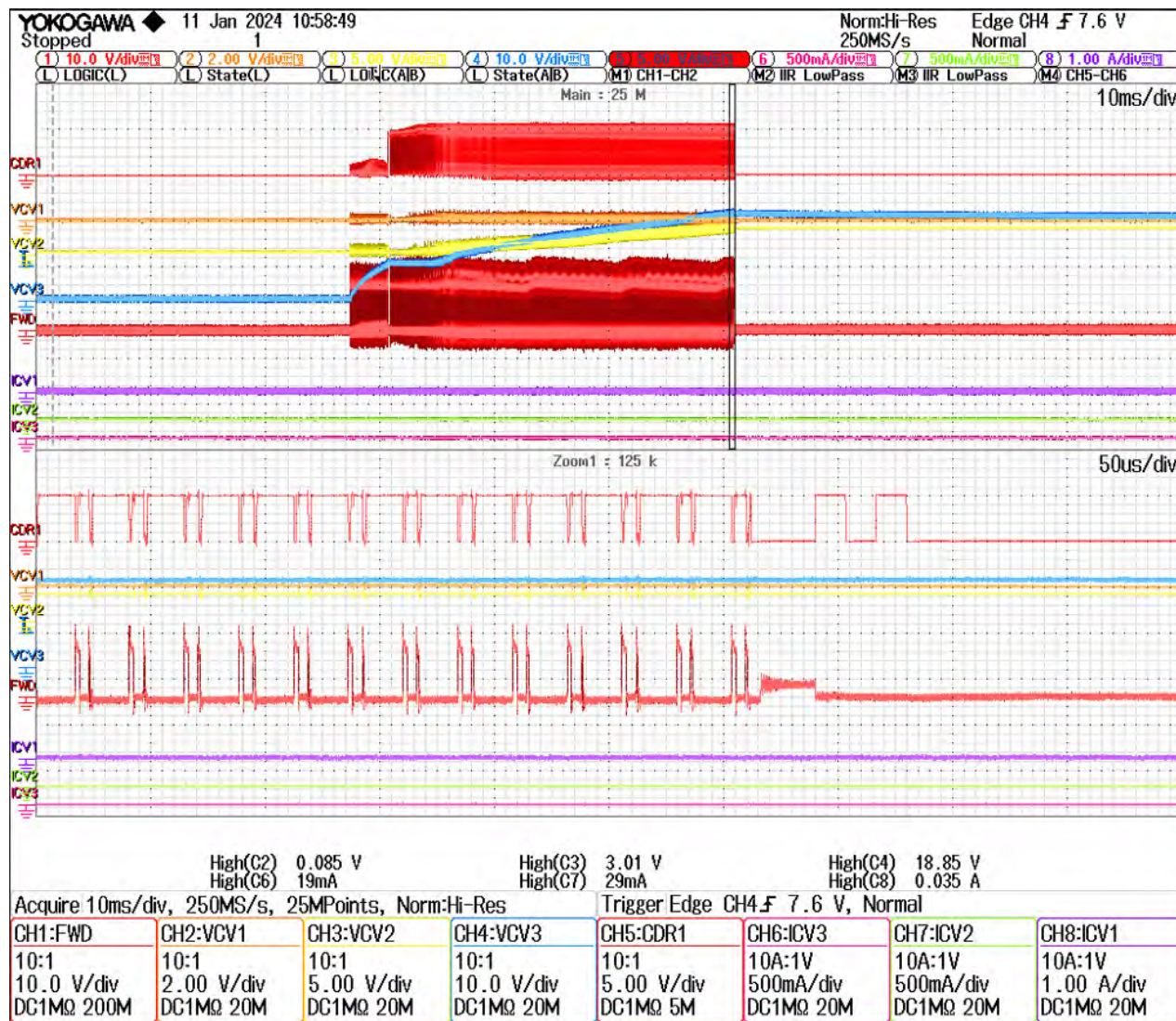

Figure 43 – Start-up With CV1 Shorted to GND. Line Input 90 V, No-Load.

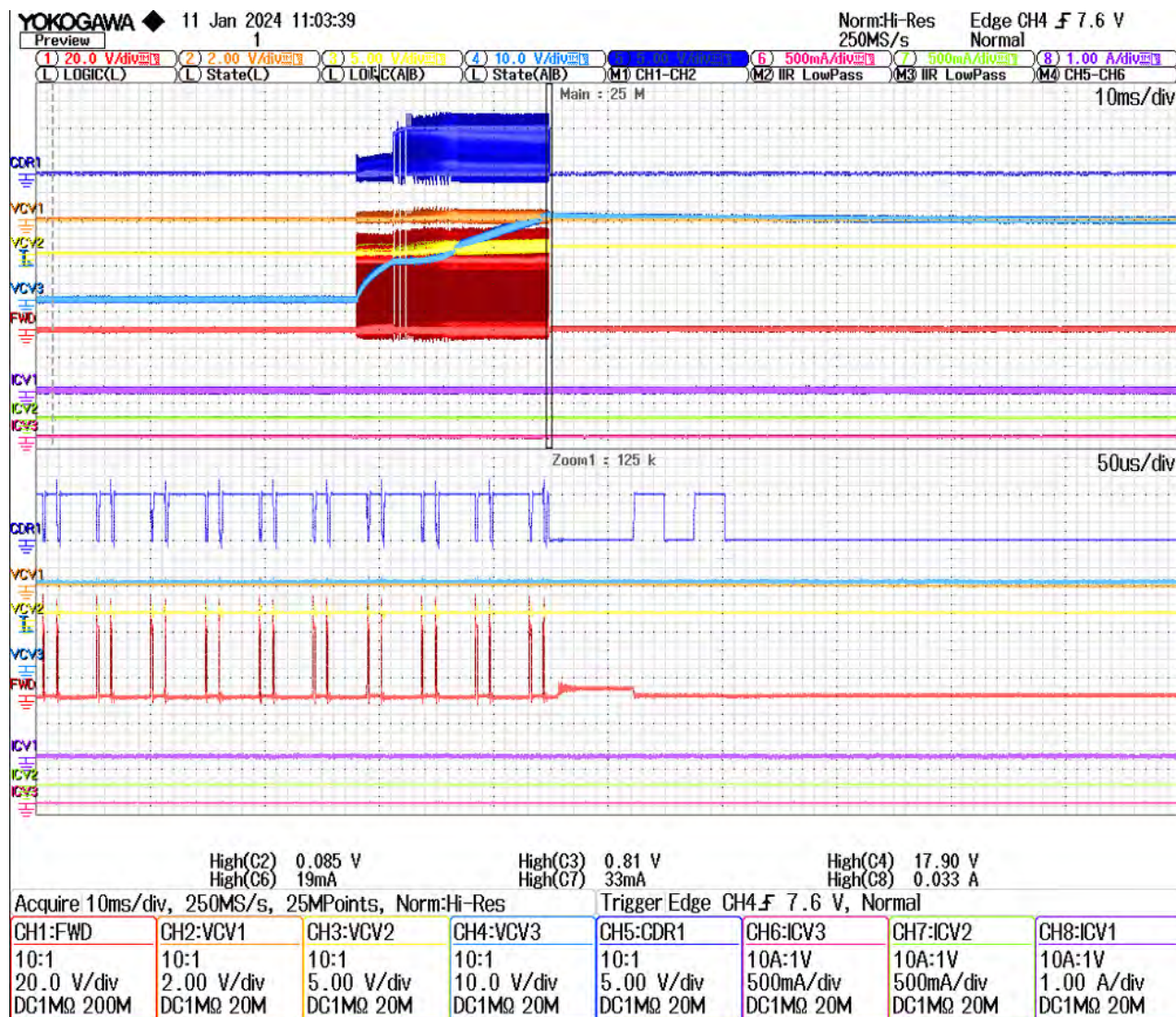

Figure 44 – Start-up With CV1 Shorted to GND. Line Input 265 V, No-Load.

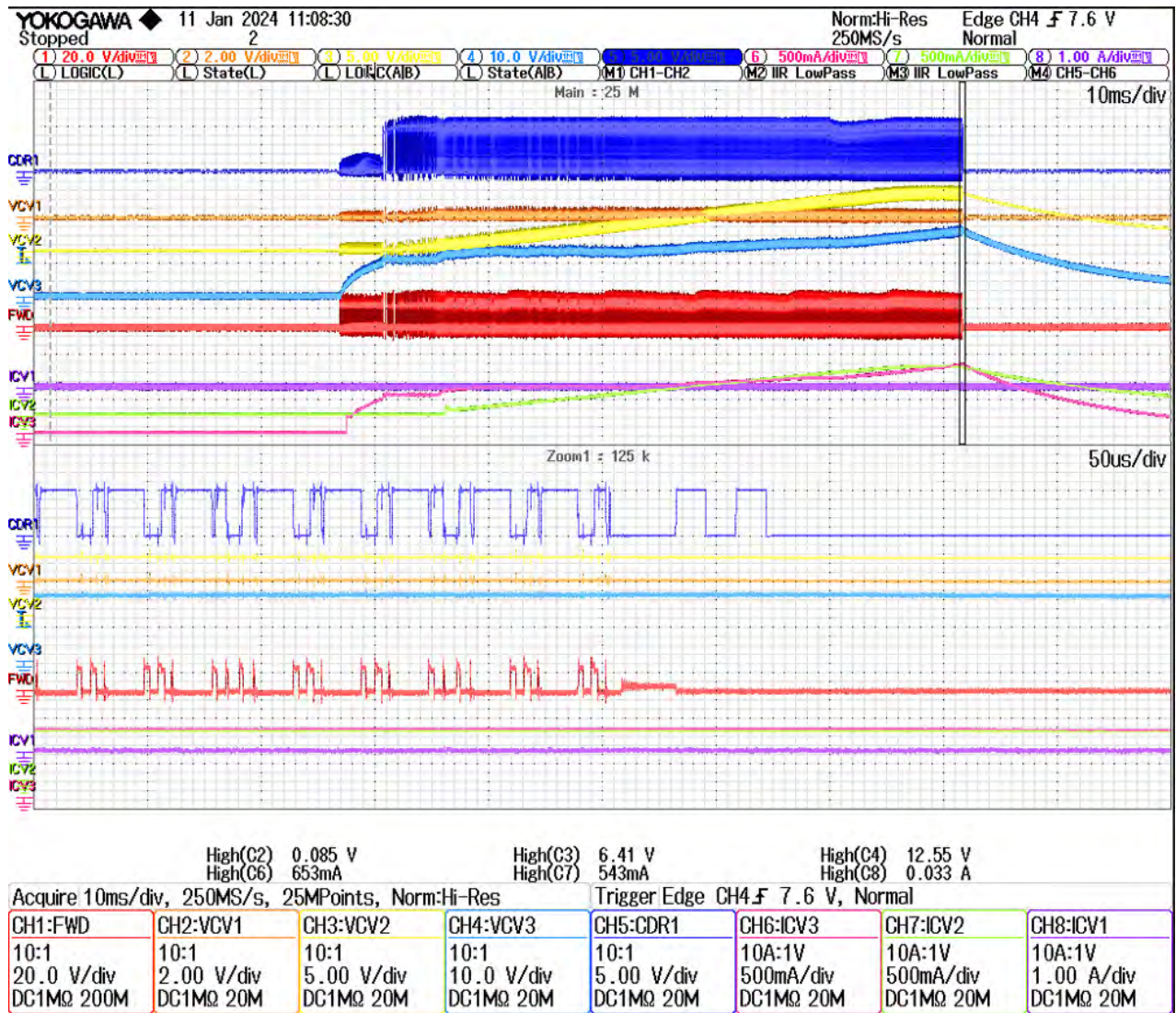

Figure 45 – Start-up With CV1 Shorted to GND. Line Input 90 V, Full Load.



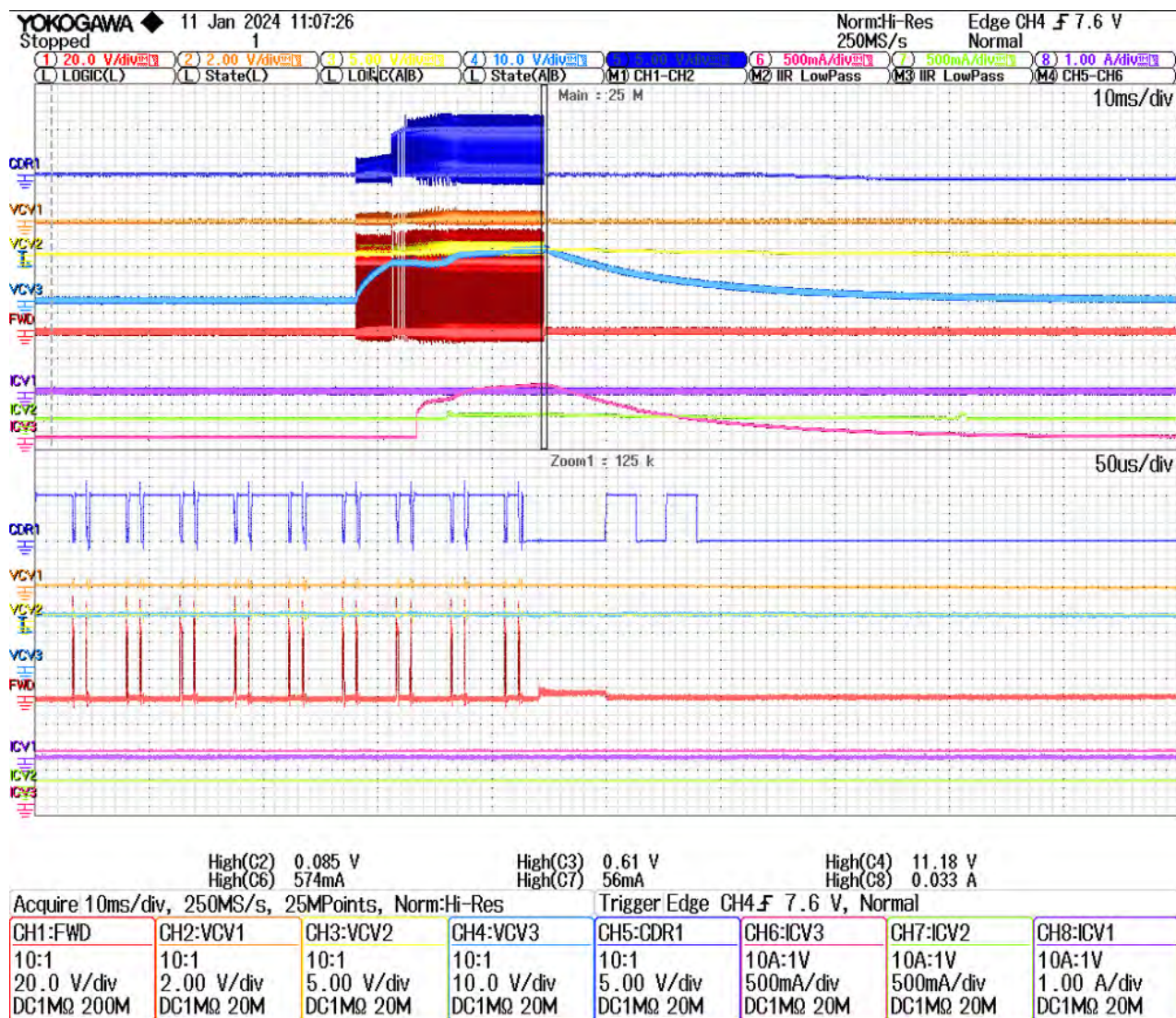

Figure 46 – Start-up With CV1 Shorted to GND. Line Input 265 V, Full Load.

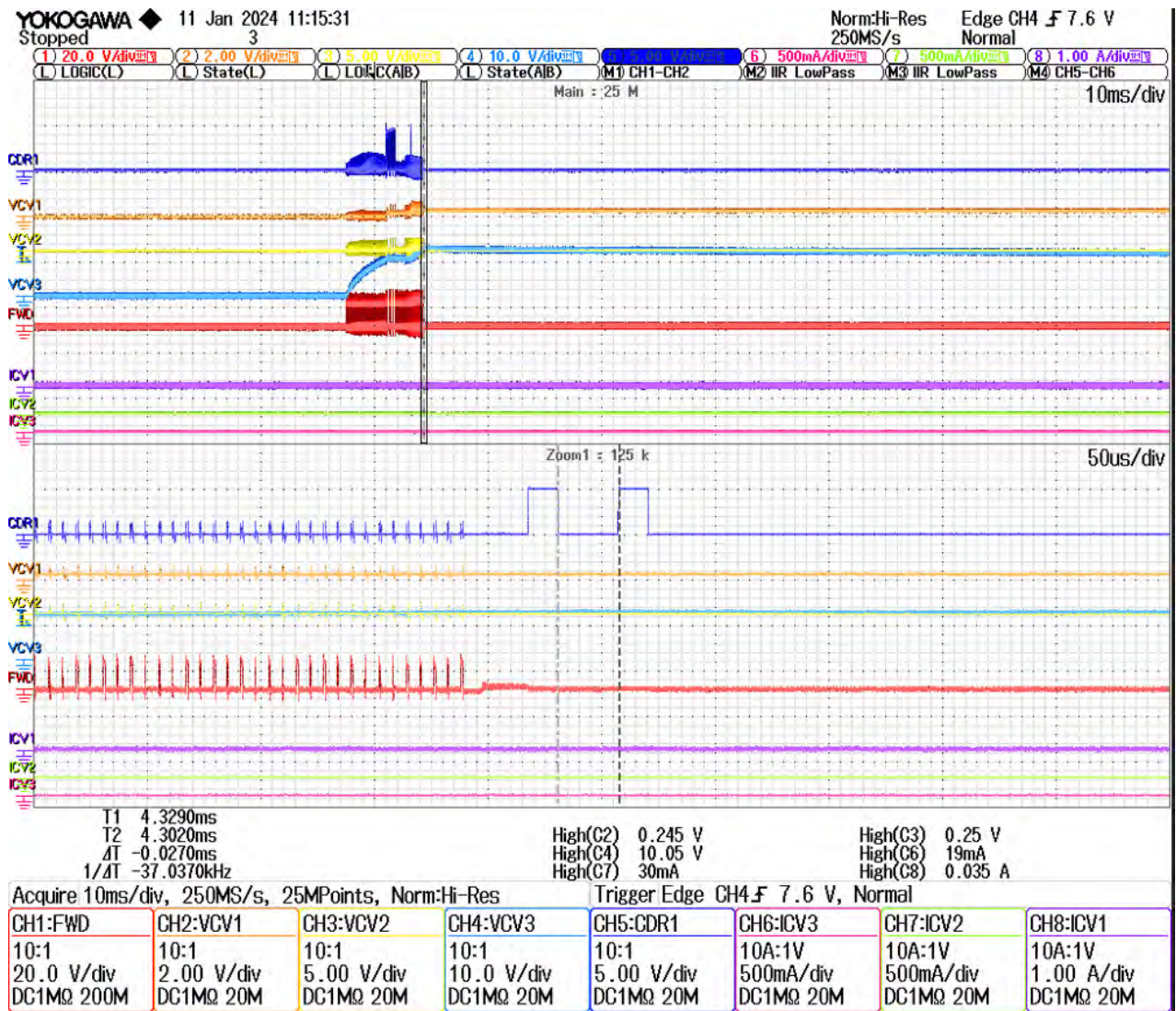

Figure 47 – Start-up With CV2 Shorted to GND. Line Input 90 V, No-Load.

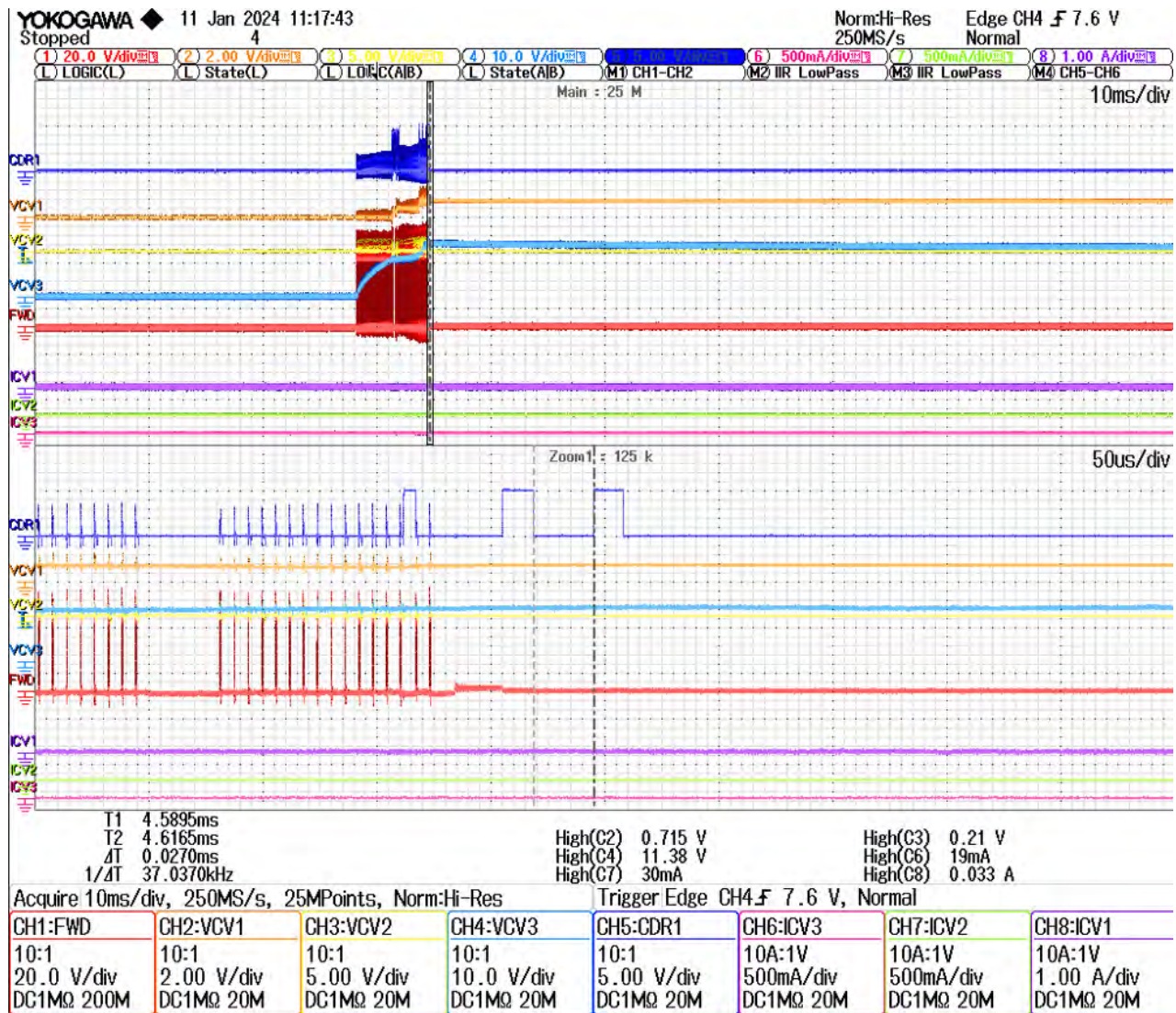

Figure 48 – Start-up With CV2 Shorted to GND. Line Input 265 V, No-Load.

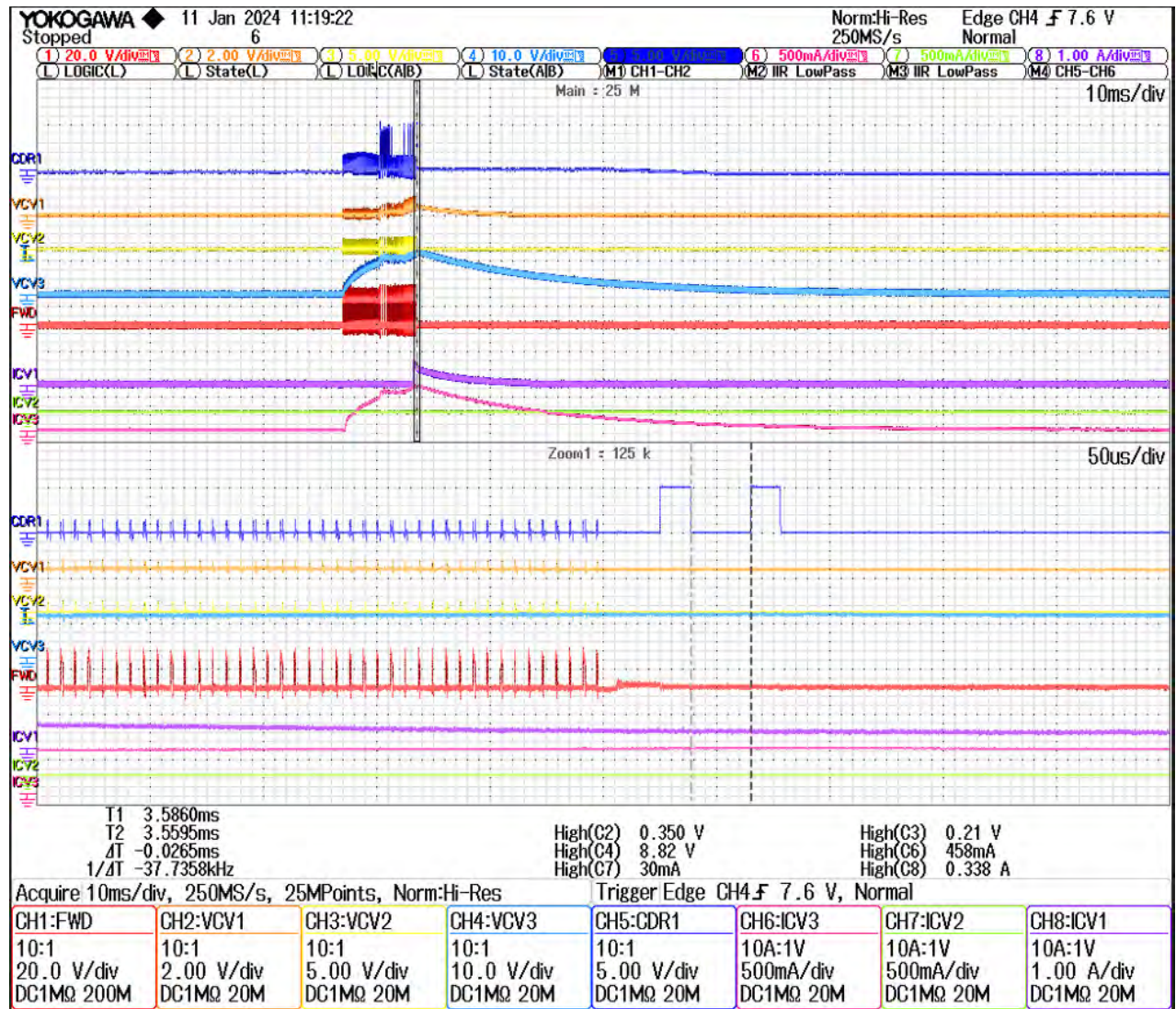

Figure 49 – Start-up With CV2 Shorted to GND. Line Input 90 V, Full Load.

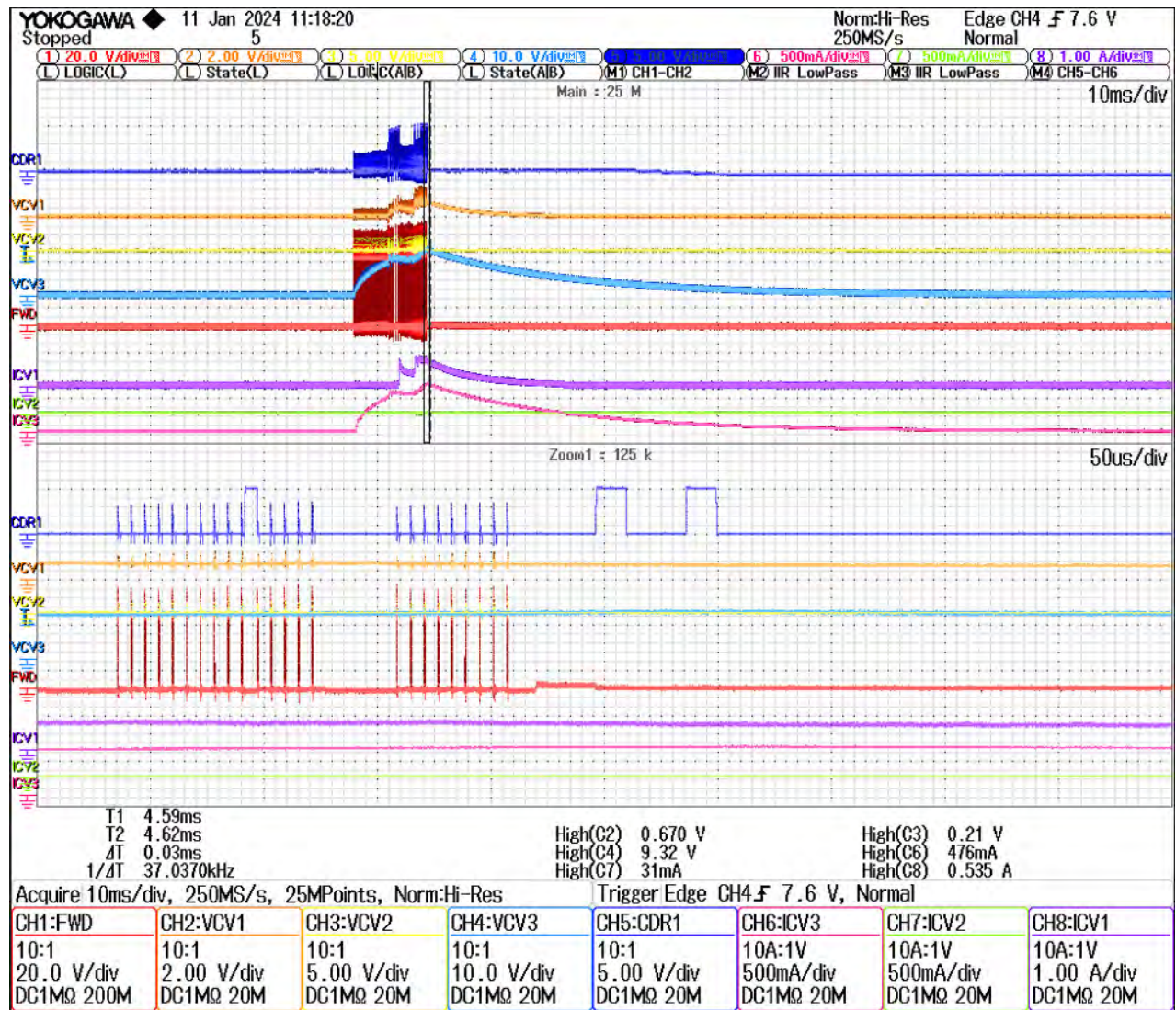

Figure 50 – Start-up With CV2 Shorted to GND. Line Input 265 V, Full Load.

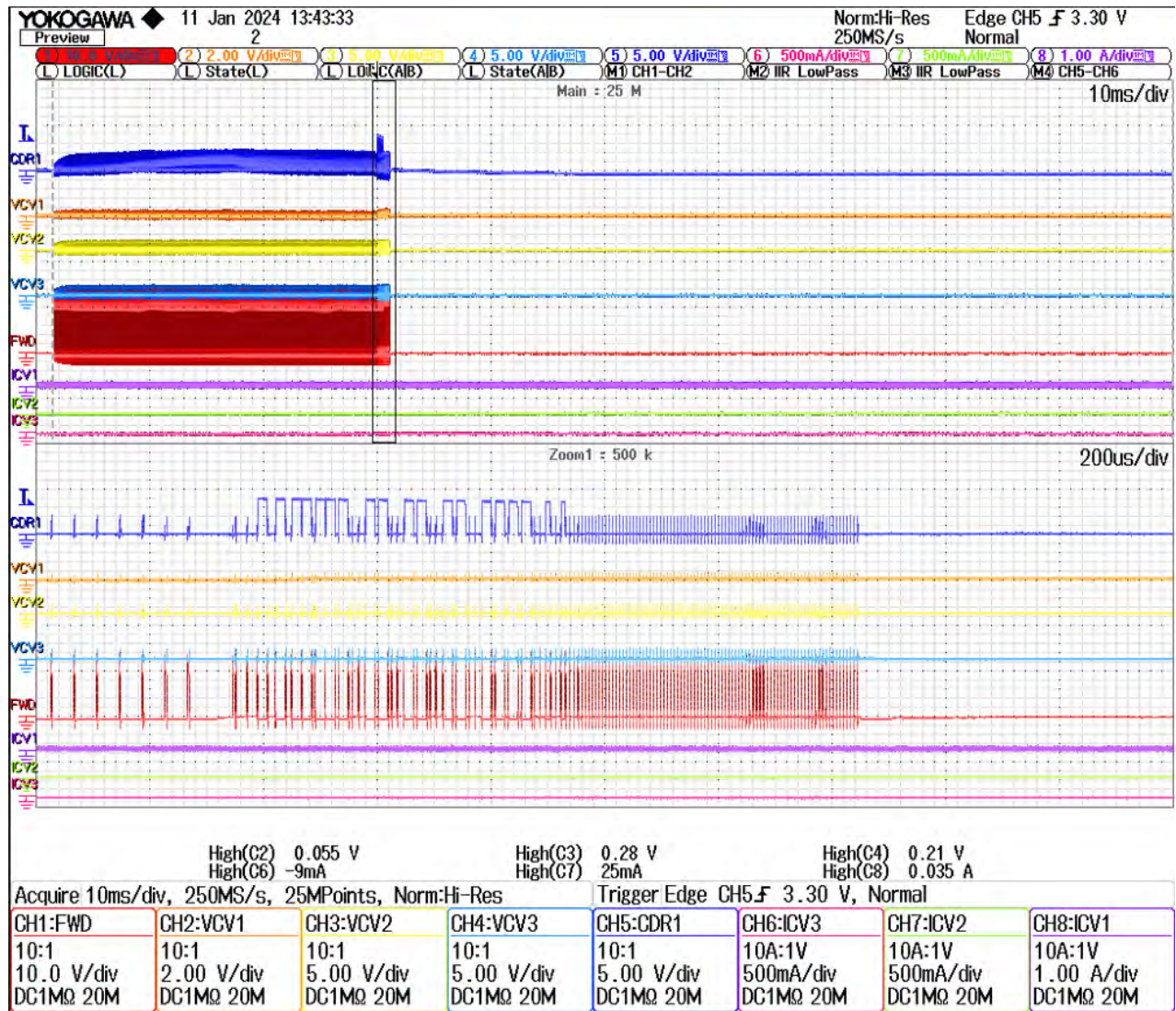

Figure 51 – Start-up With CV3 Shorted to GND. Line Input 90 V, No-Load.

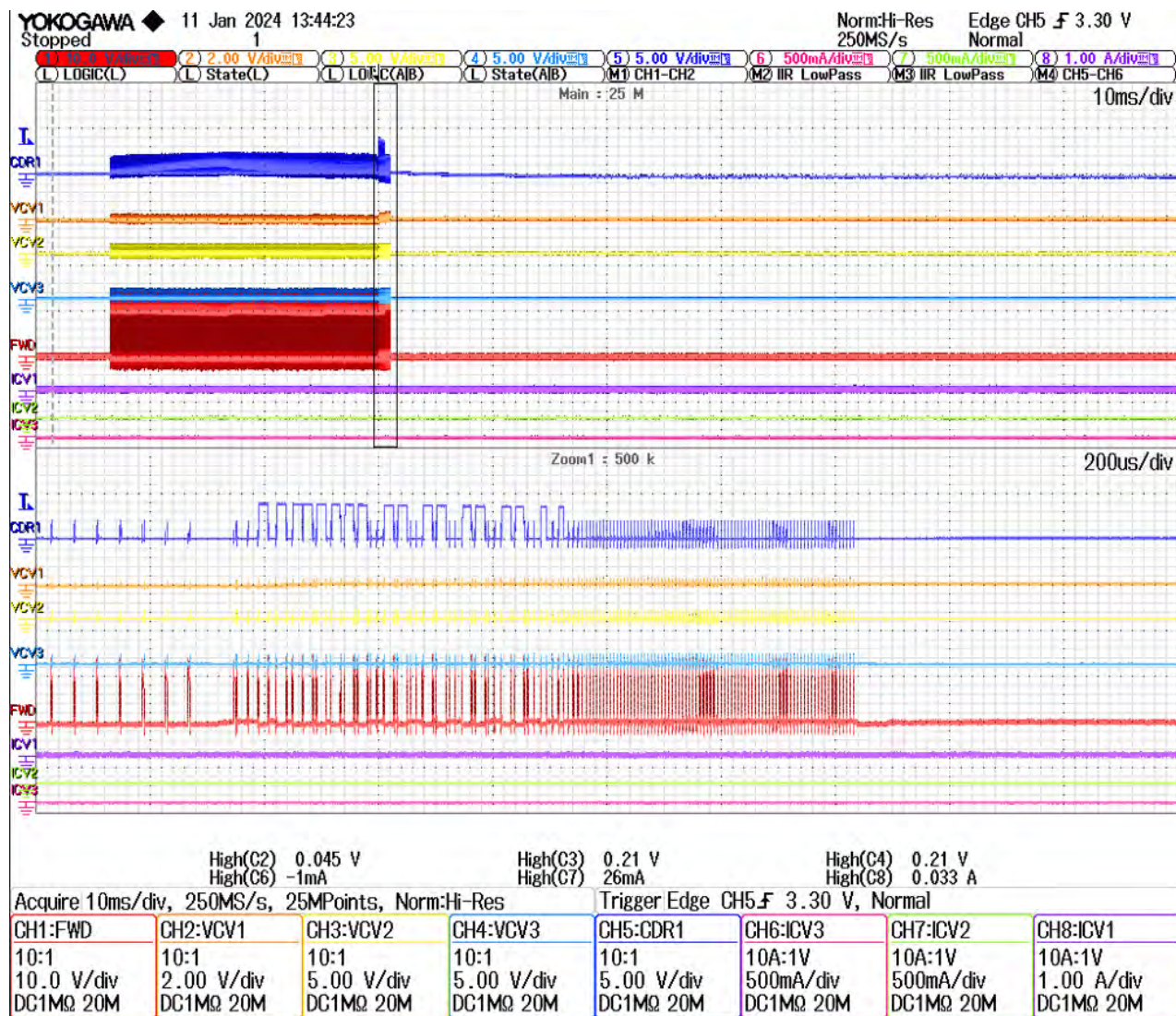

Figure 52 – Start-up with CV3 Shorted to GND. Line Input 90 V, Full Load.

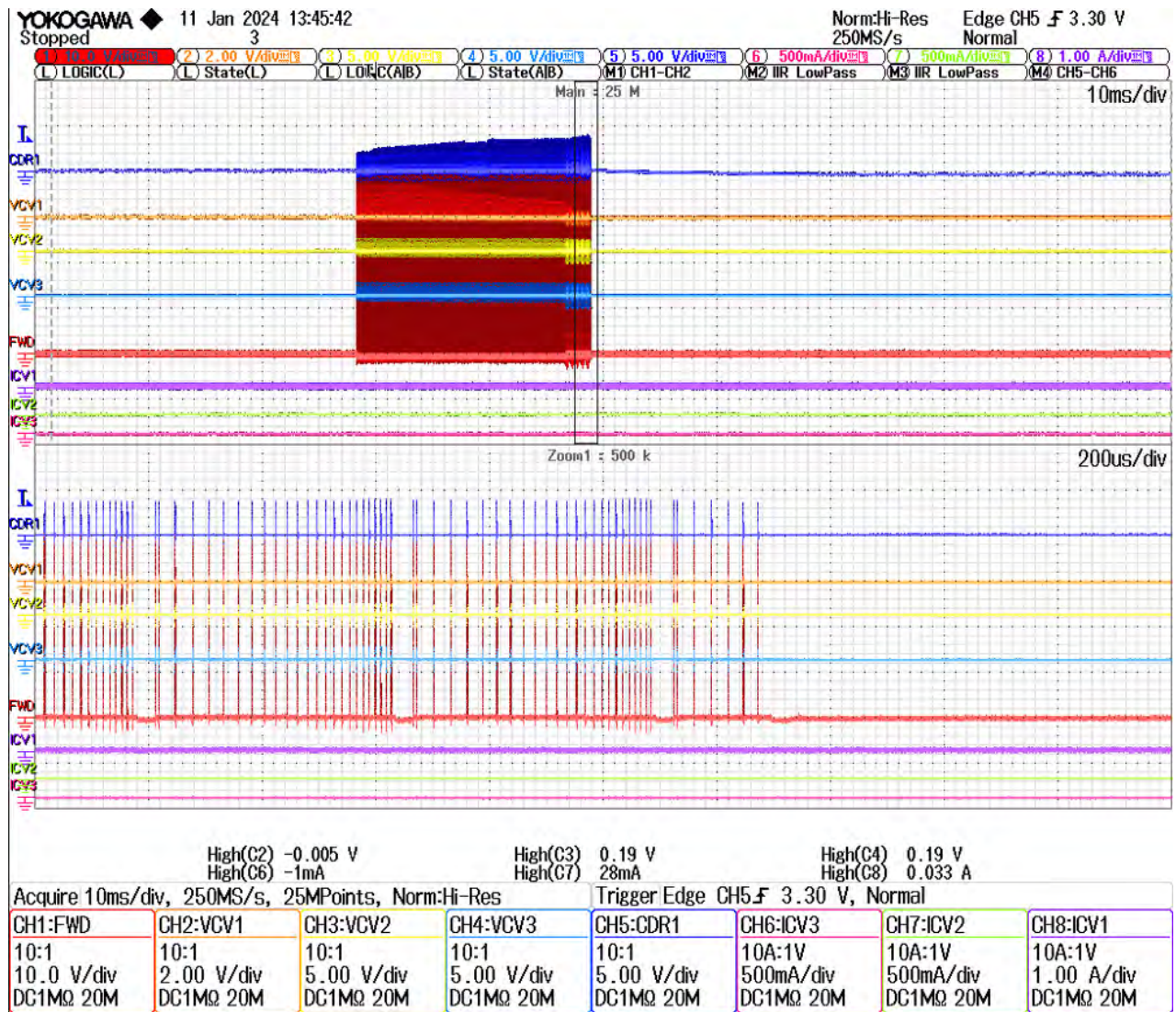

Figure 53 – Start-up with CV3 Shorted to GND. Line Input 265 V, No-Load.



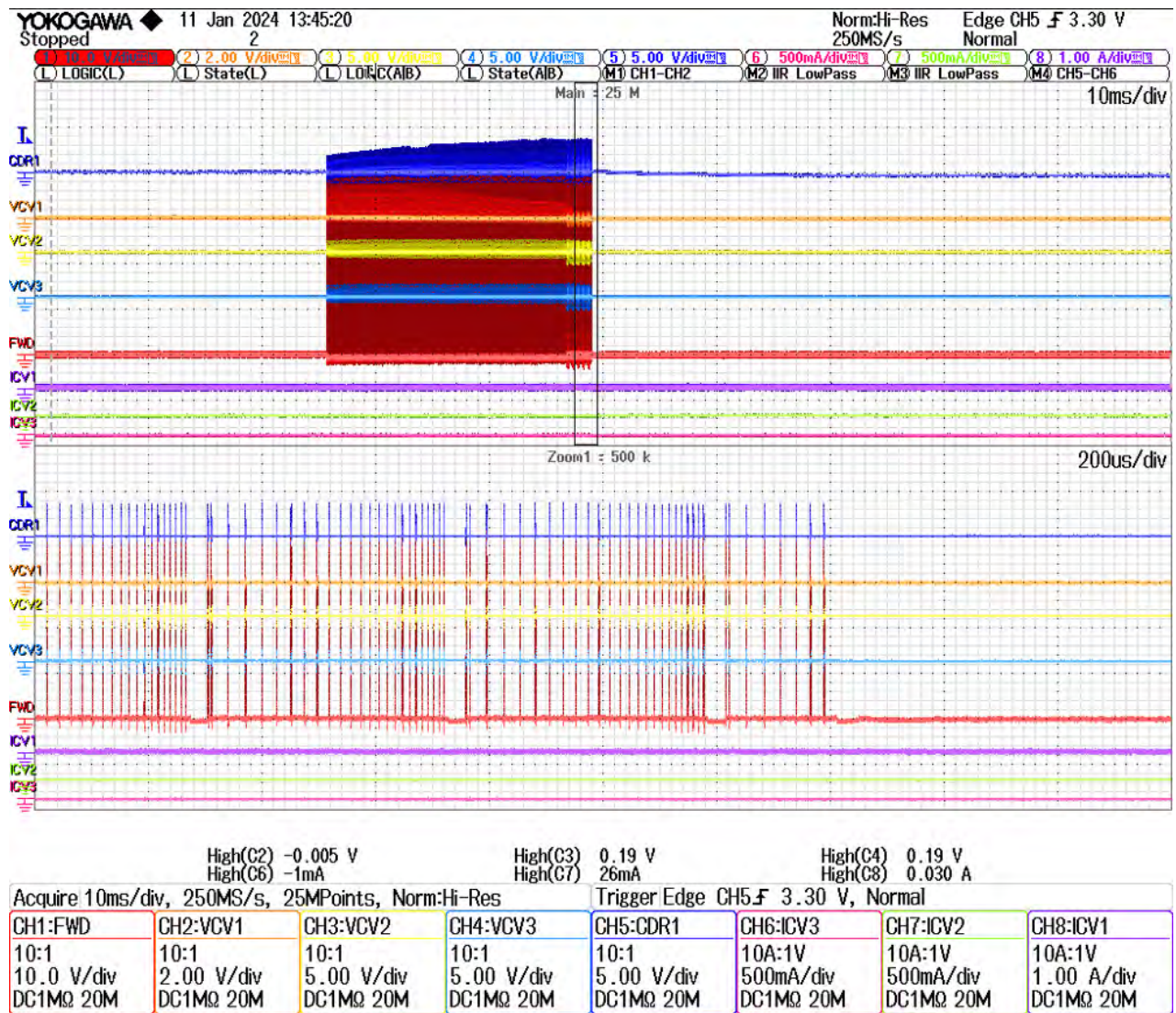

Figure 54 – Start-up With CV3 Shorted to GND. Line Input 265 V, Full Load.

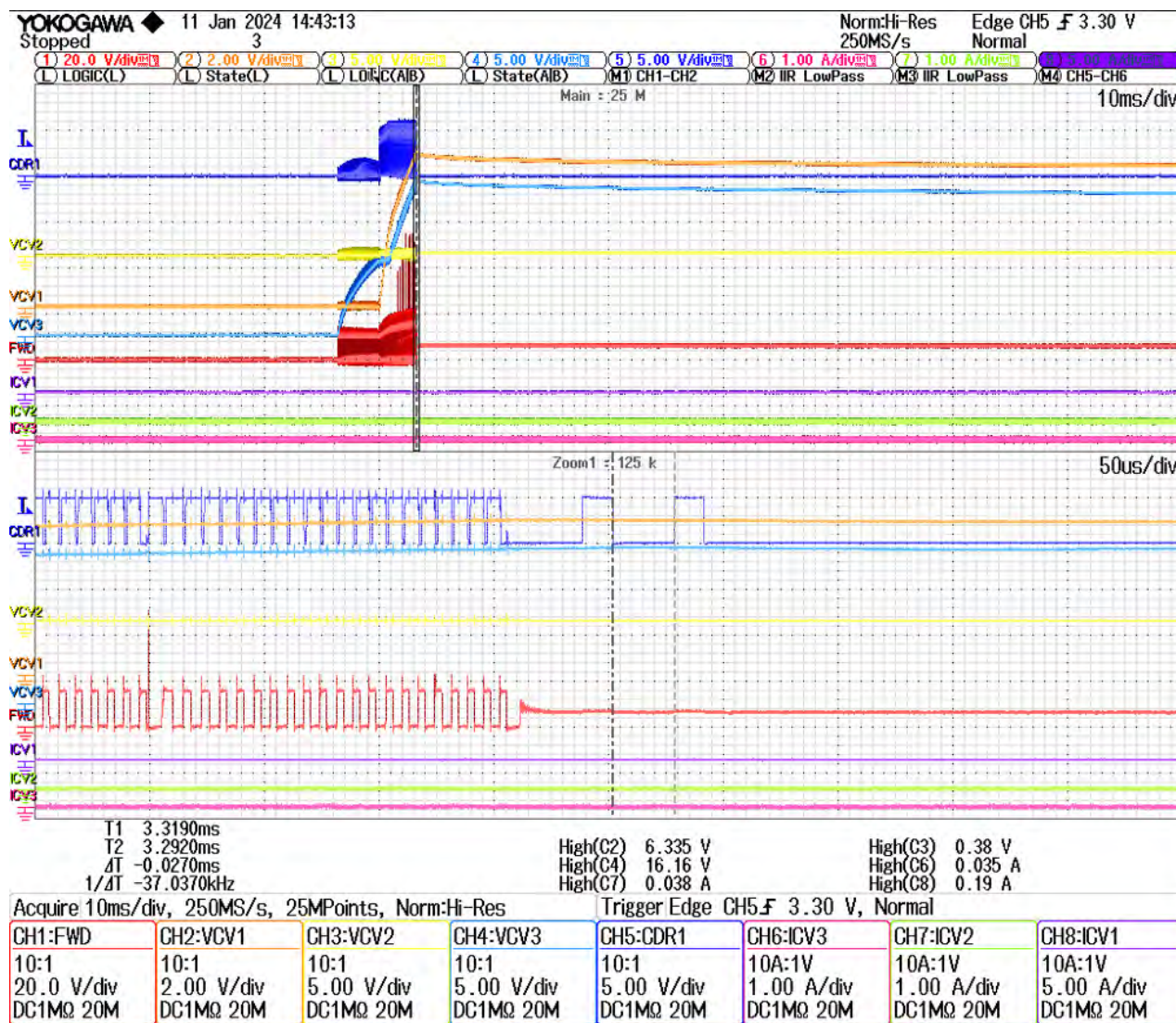

Figure 55 – Start-up With FB1 Open. Line Input 90 V, No-Load.

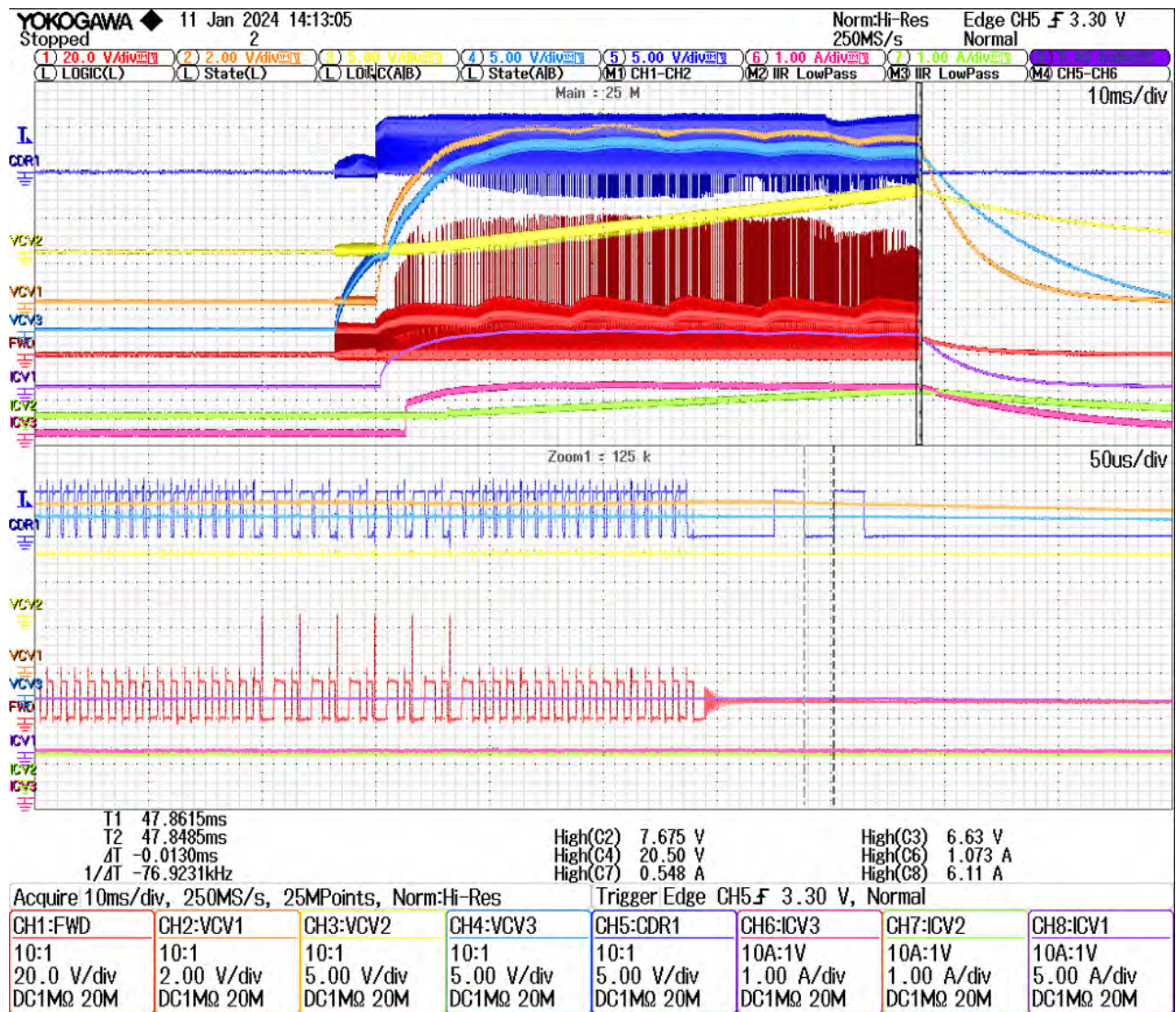

Figure 56 – Start-up With FB1 Open. Line Input 90 V, Full Load.

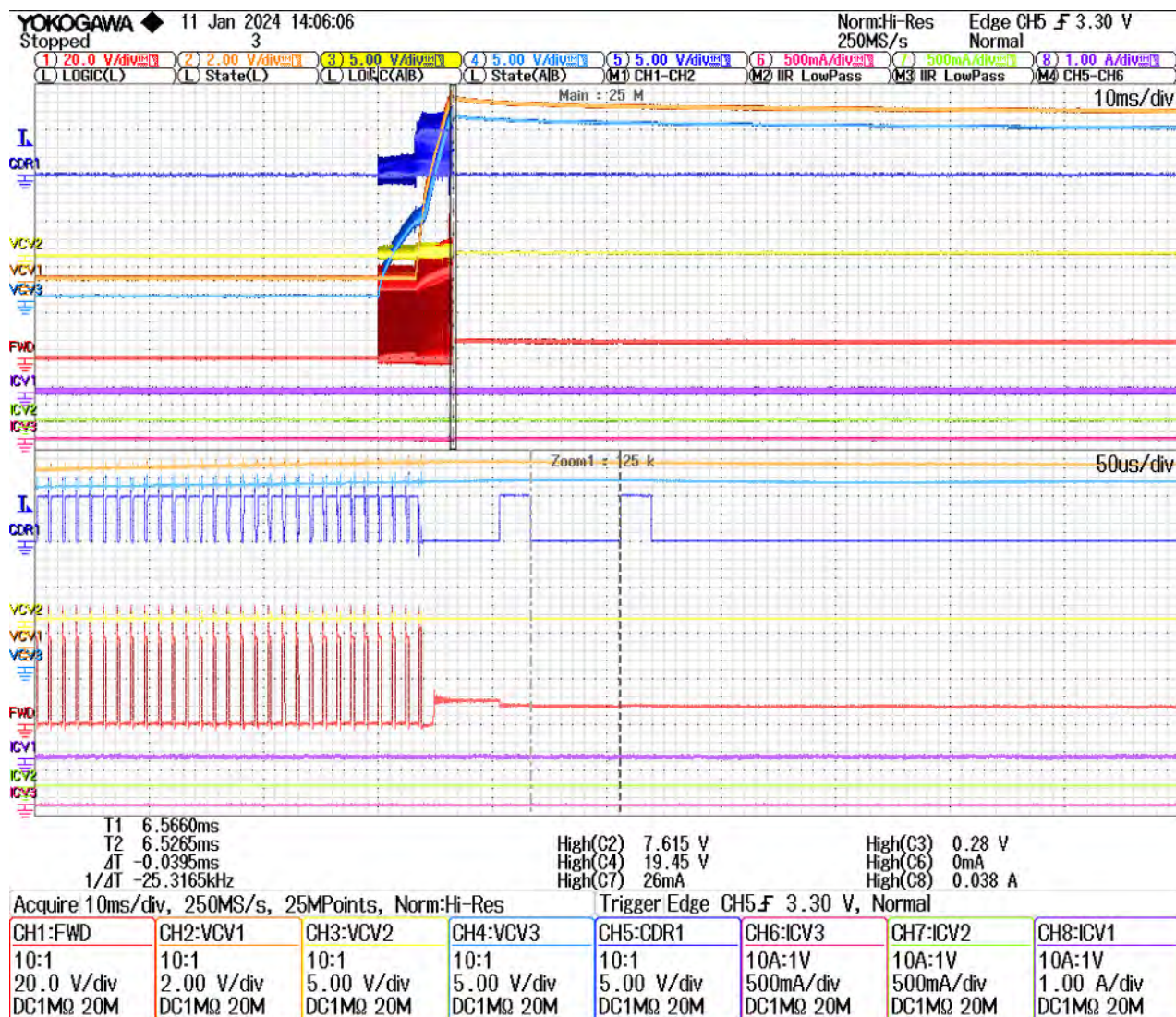

Figure 57 – Start-up With FB1 Open. Line Input 265 V, No-Load.

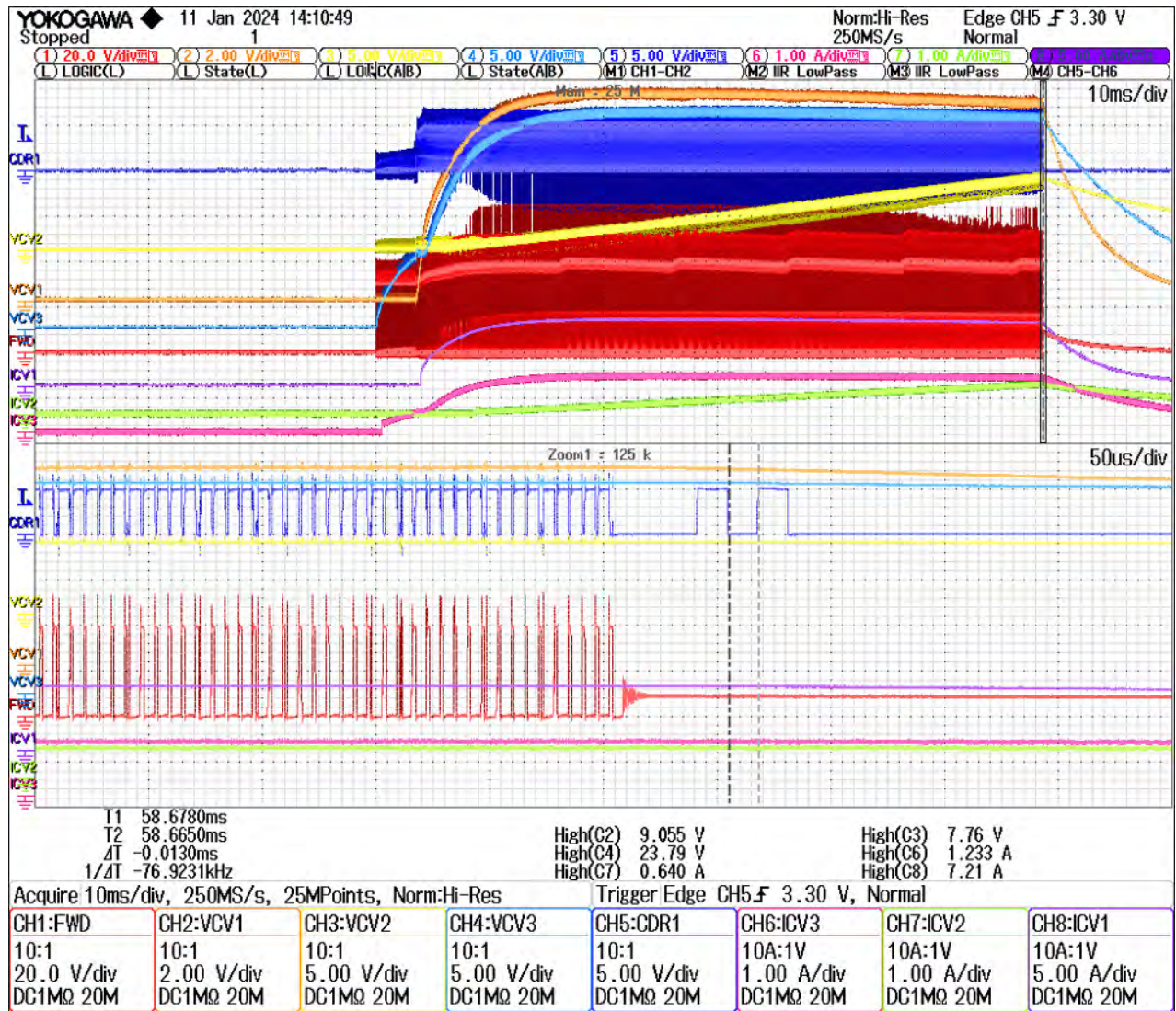

Figure 58 – Start-up With FB1 Open. Line Input 265 V, Full Load.

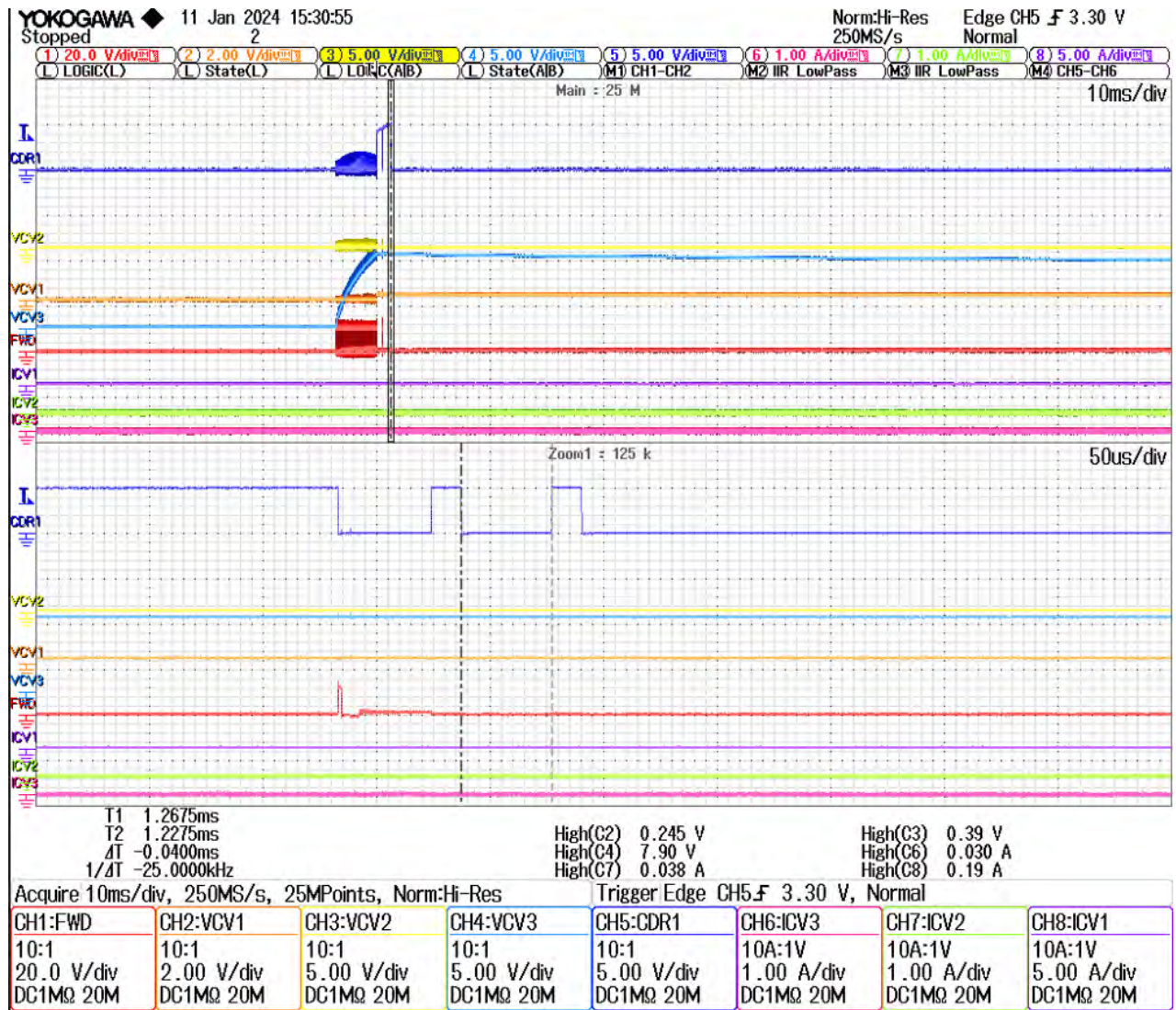

Figure 59 – Start-up With FB2 Open. Line Input 90 V, No-Load.

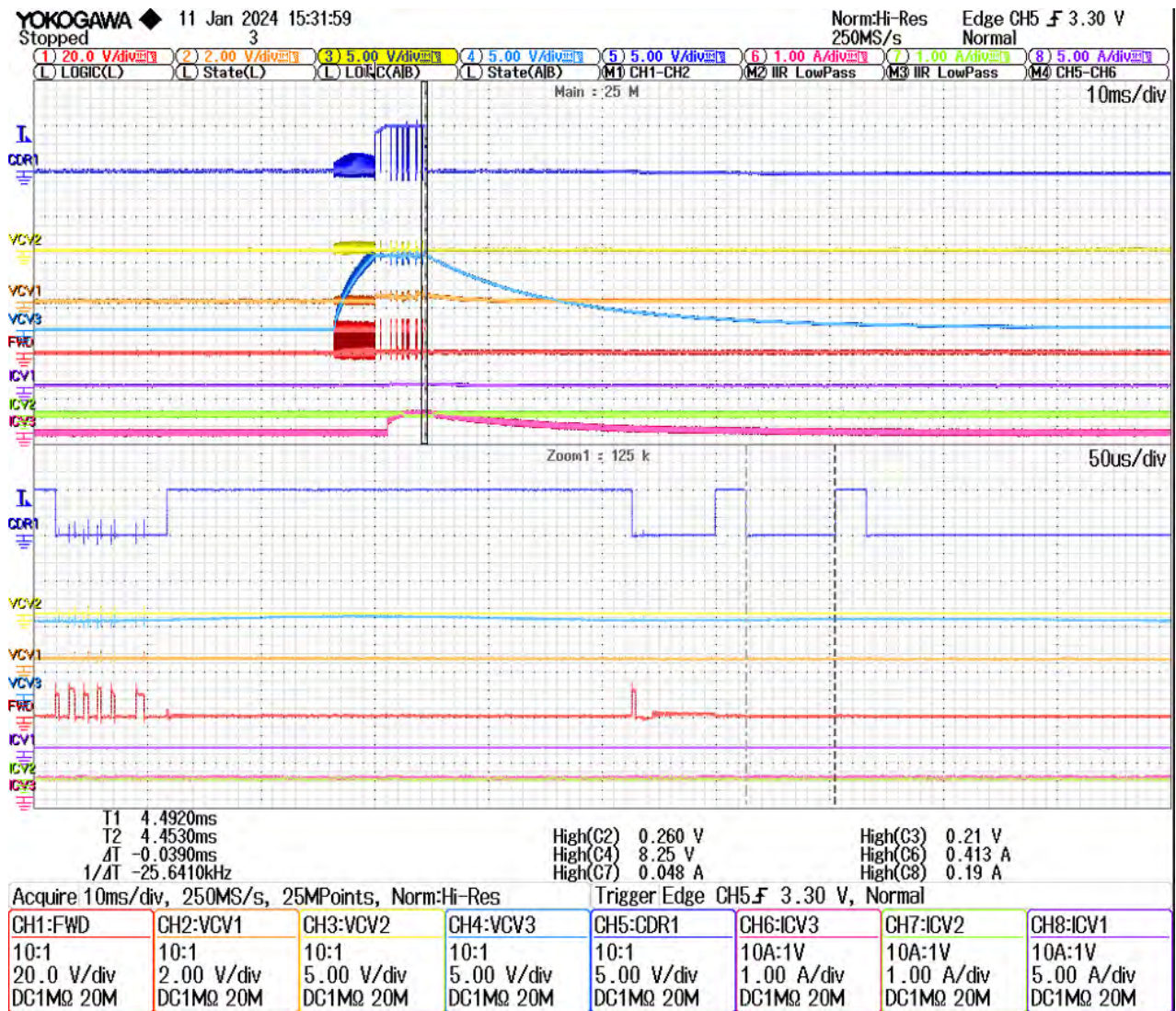

Figure 60 – Start-up With FB2 Open. Line Input 90 V, Full Load.

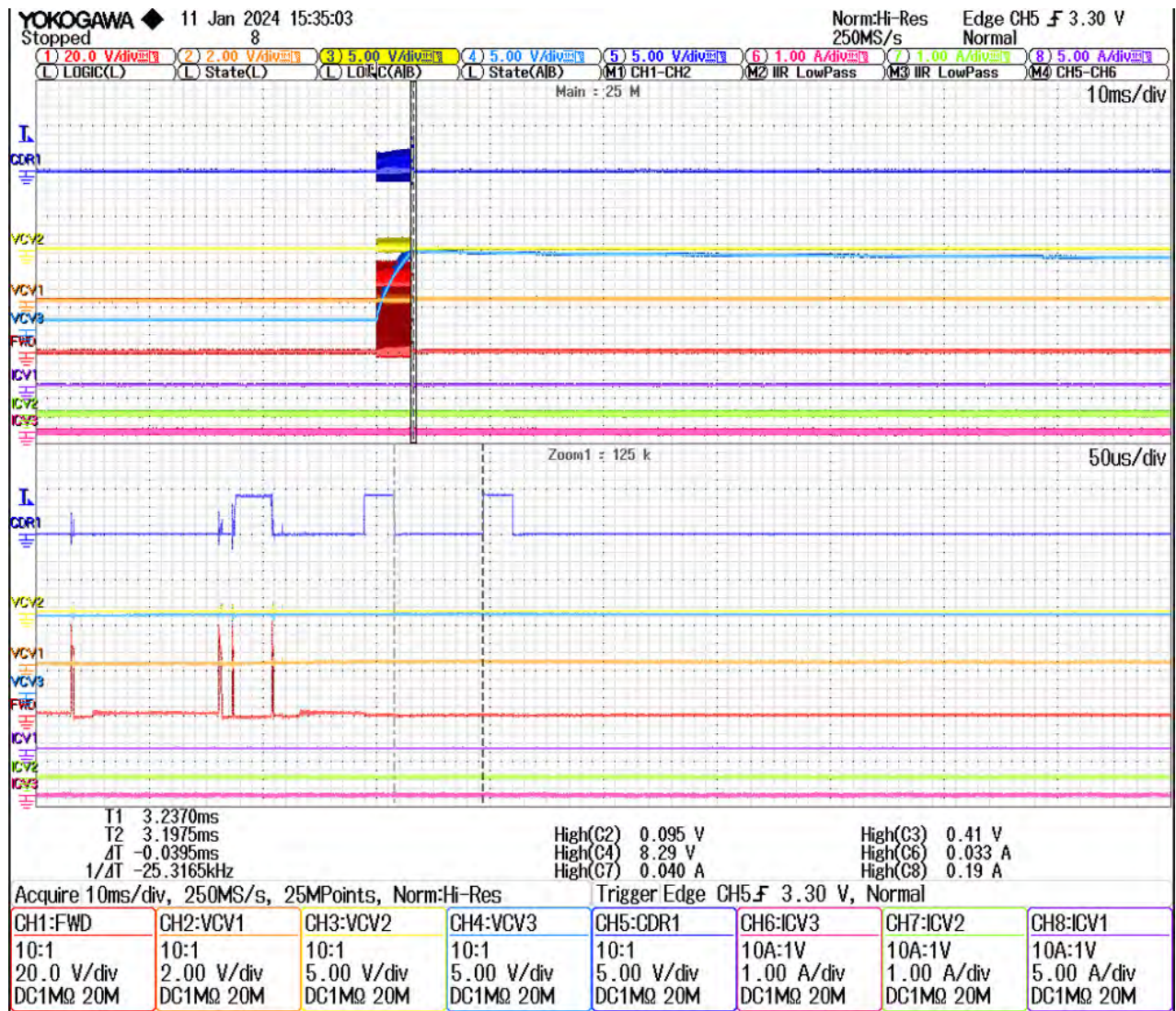

Figure 61 – Start-up With FB2 Open. Line Input 265 V, No-Load.



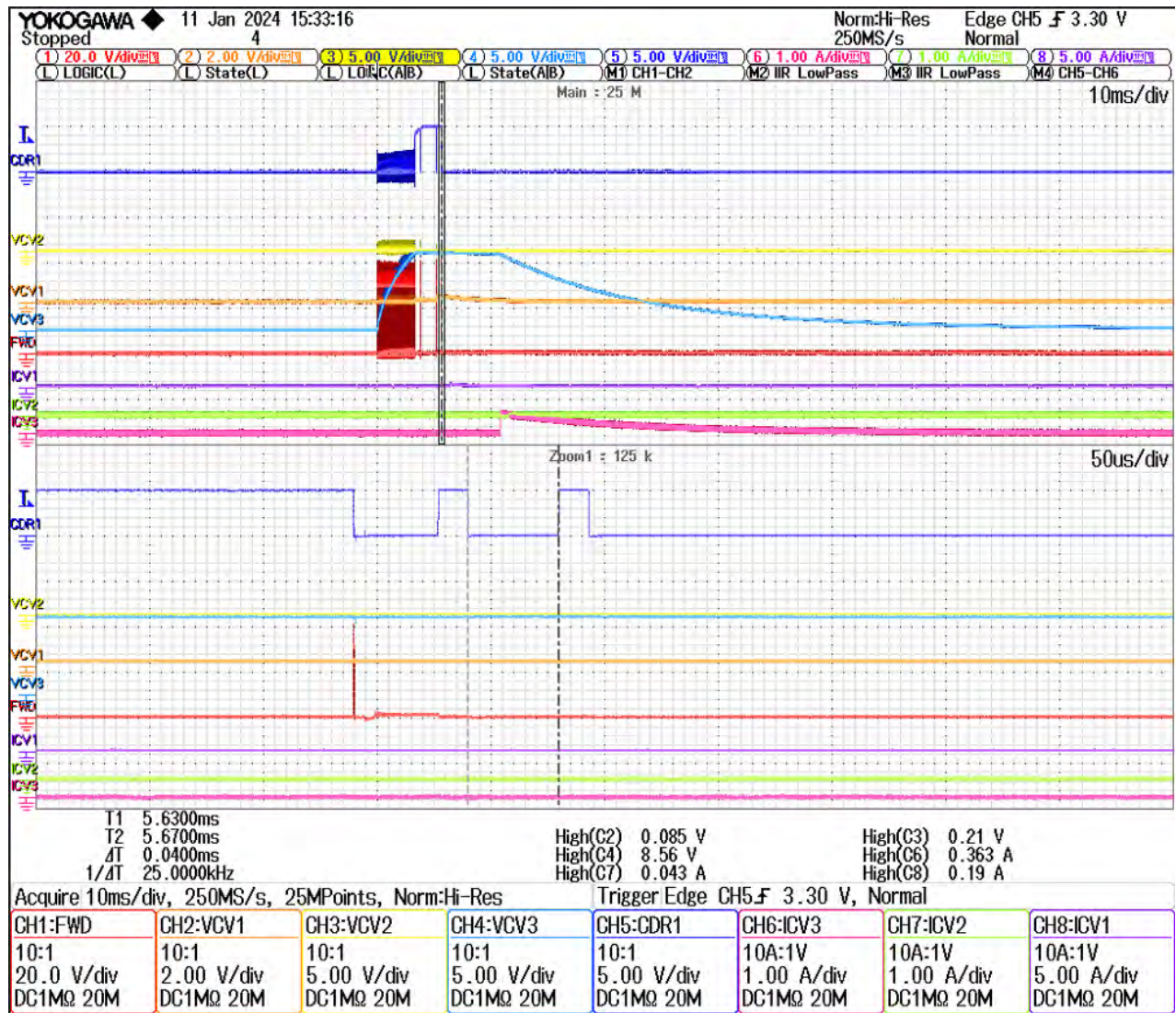

Figure 62 – Start-up With FB2 Open. Line Input 265 V, Full Load.

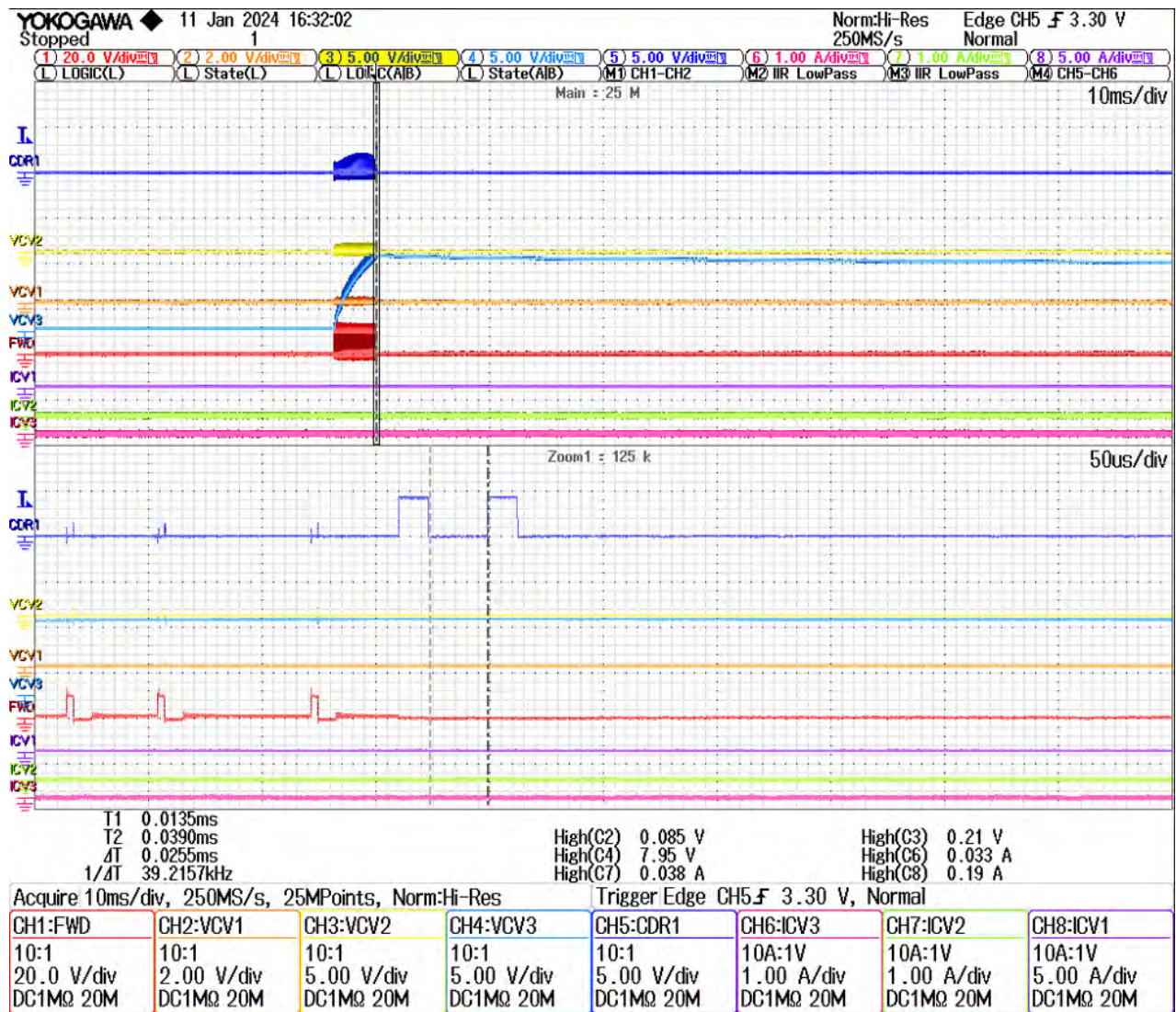

Figure 63 – Start-up With FB3 Open. Line Input 90 V, No-Load.

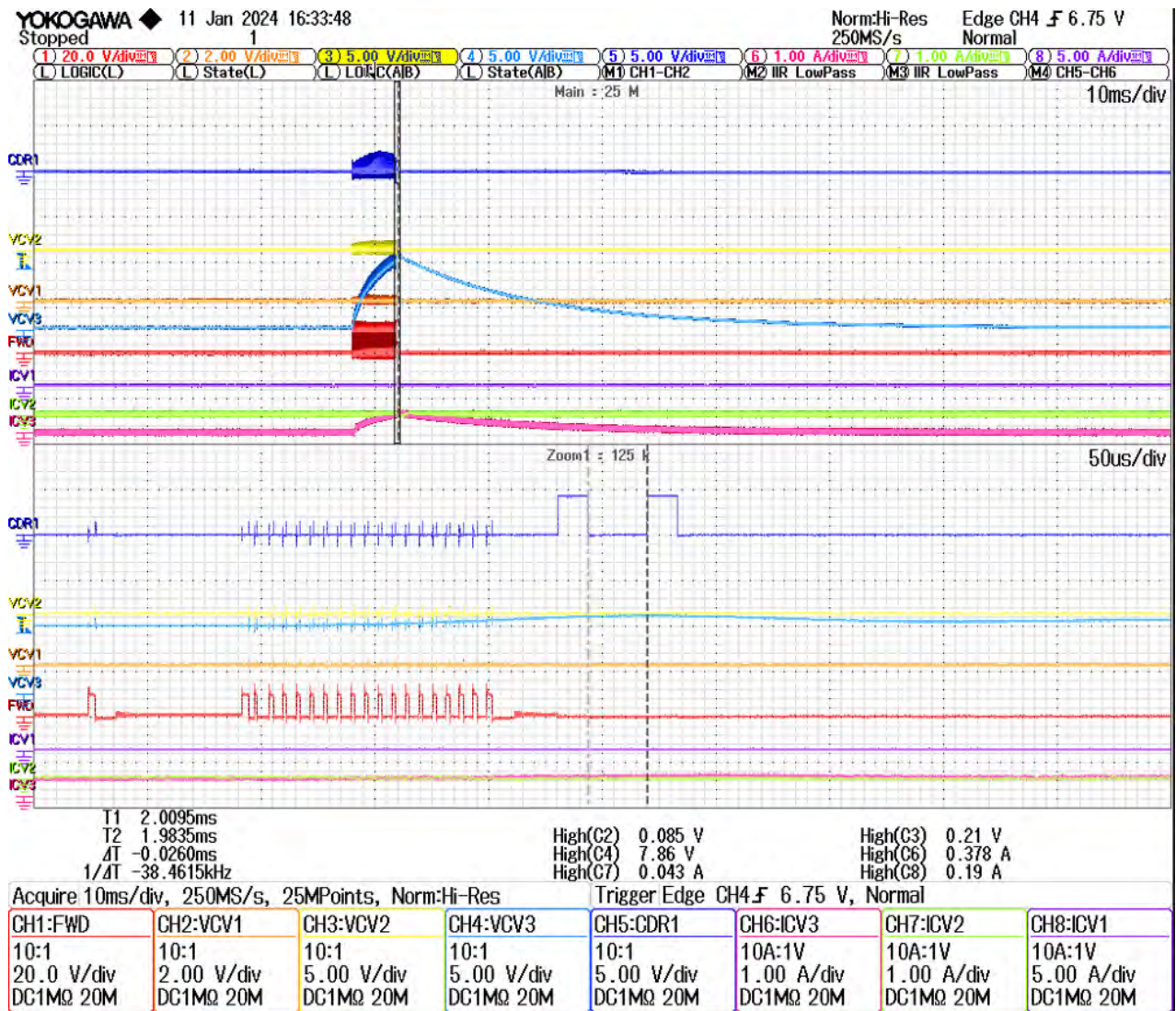

Figure 64 – Start-up With FB3 Open. Line Input 90 V, Full Load.

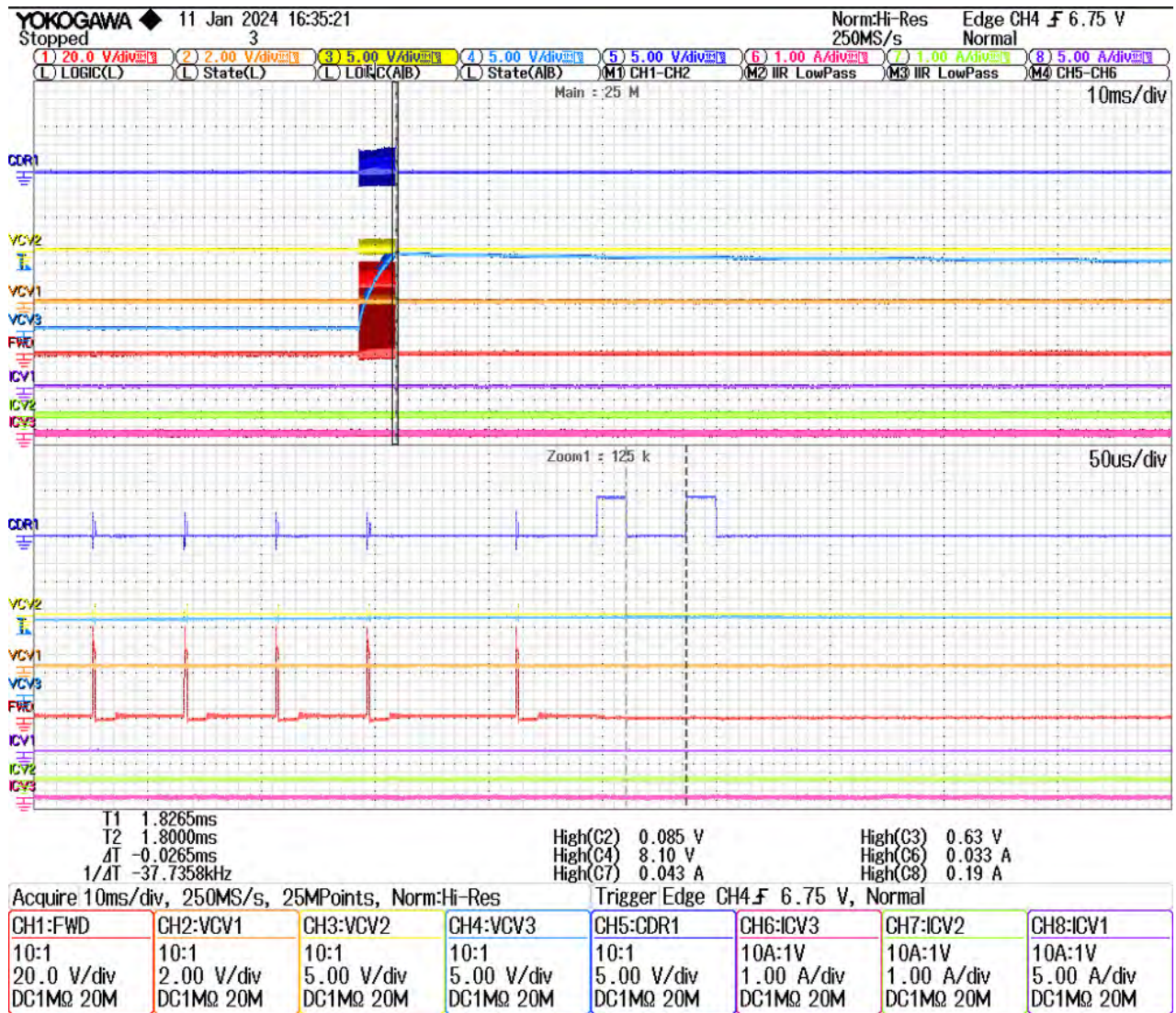

Figure 65 – Start-up With FB3 Open. Line Input 265 V, No-Load.

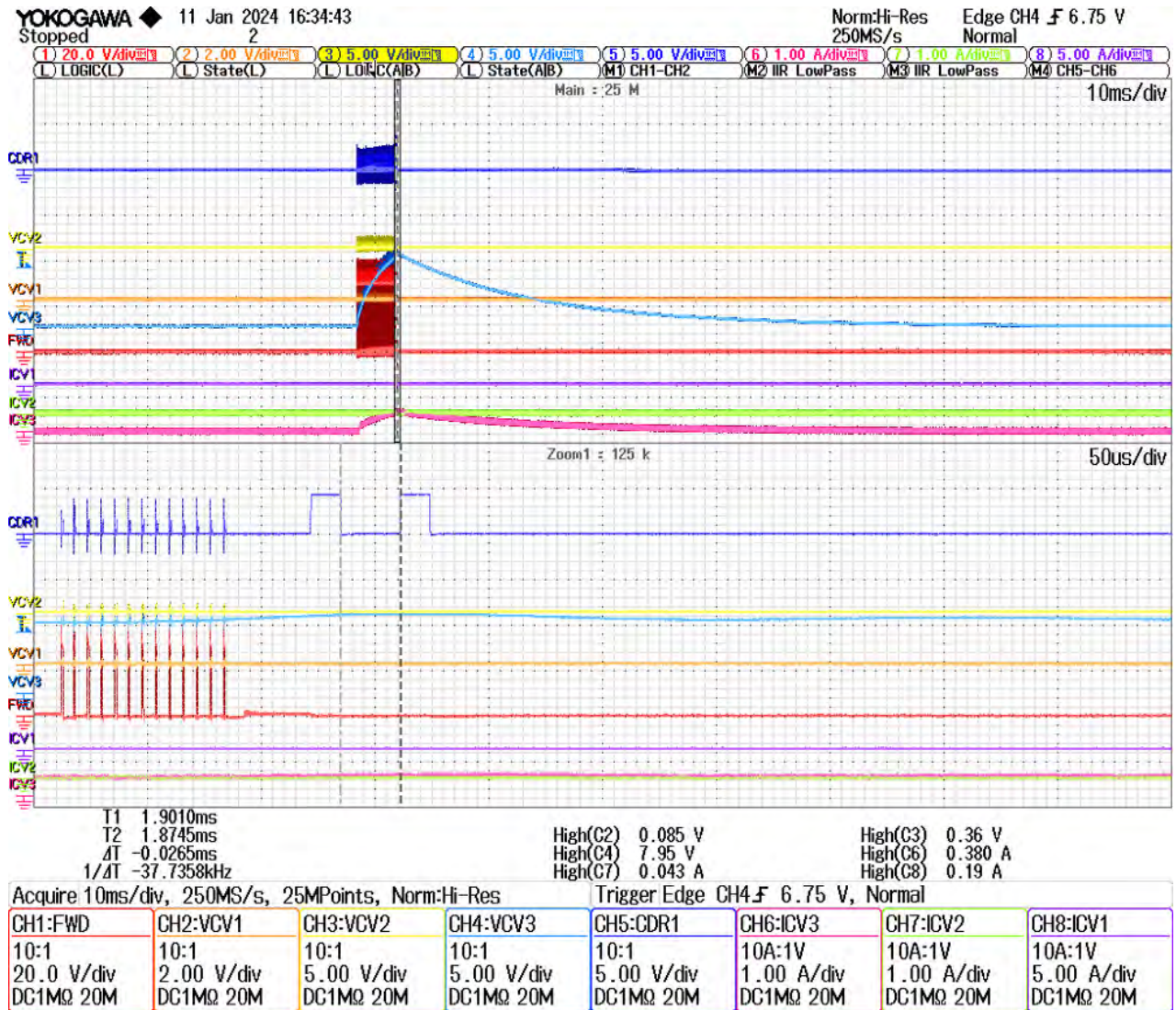

Figure 66 – Start-up With FB3 Open. Line Input 265 V, Full Load.

### 9.9 Component Peak Voltages

#### 9.9.1 SR FET Drain-Source Voltage



Figure 67 – SR FET(Q1)  $V_{DS}$  Voltage Under Full Load at 265 VAC.

Ch1:  $V_{SR}$ , Ch5:  $SR_{GATE}$ , Ch6:  $ICV3$ , Ch7:  $ICV2$ , Ch8:  $ICV1$

Maximum D-S voltage across the SR FET is 53 V.

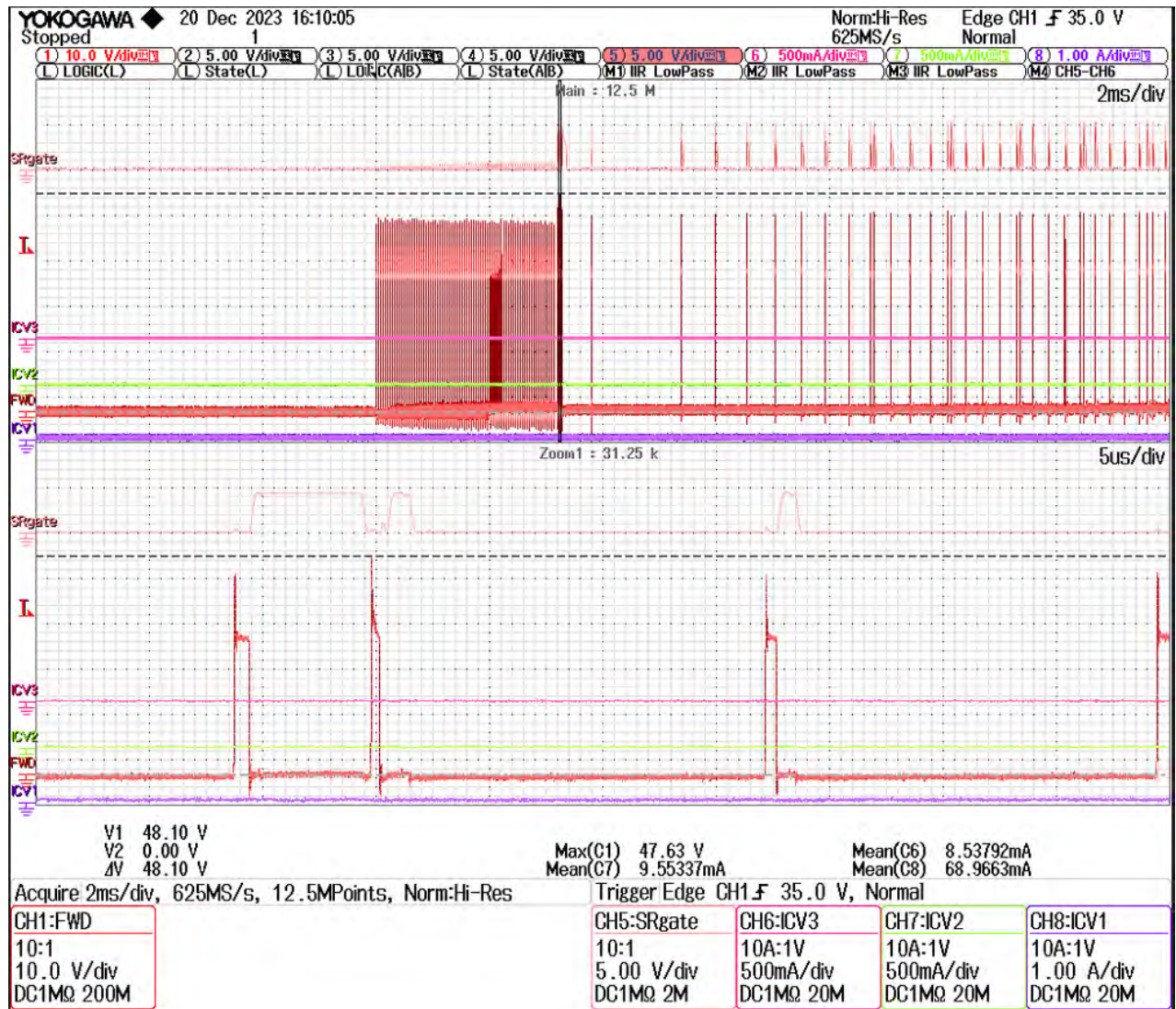

Figure 68 – SR FET(Q1)  $V_{DS}$  Voltage Under at Start-up at 265 VAC.

Ch1:  $V_{SR}$ , Ch5: SRGATE, Ch6:  $I_{CV3}$ , Ch7:  $I_{CV2}$ , Ch8:  $I_{CV1}$

Maximum D-S voltage across the SR FET is 48 V.

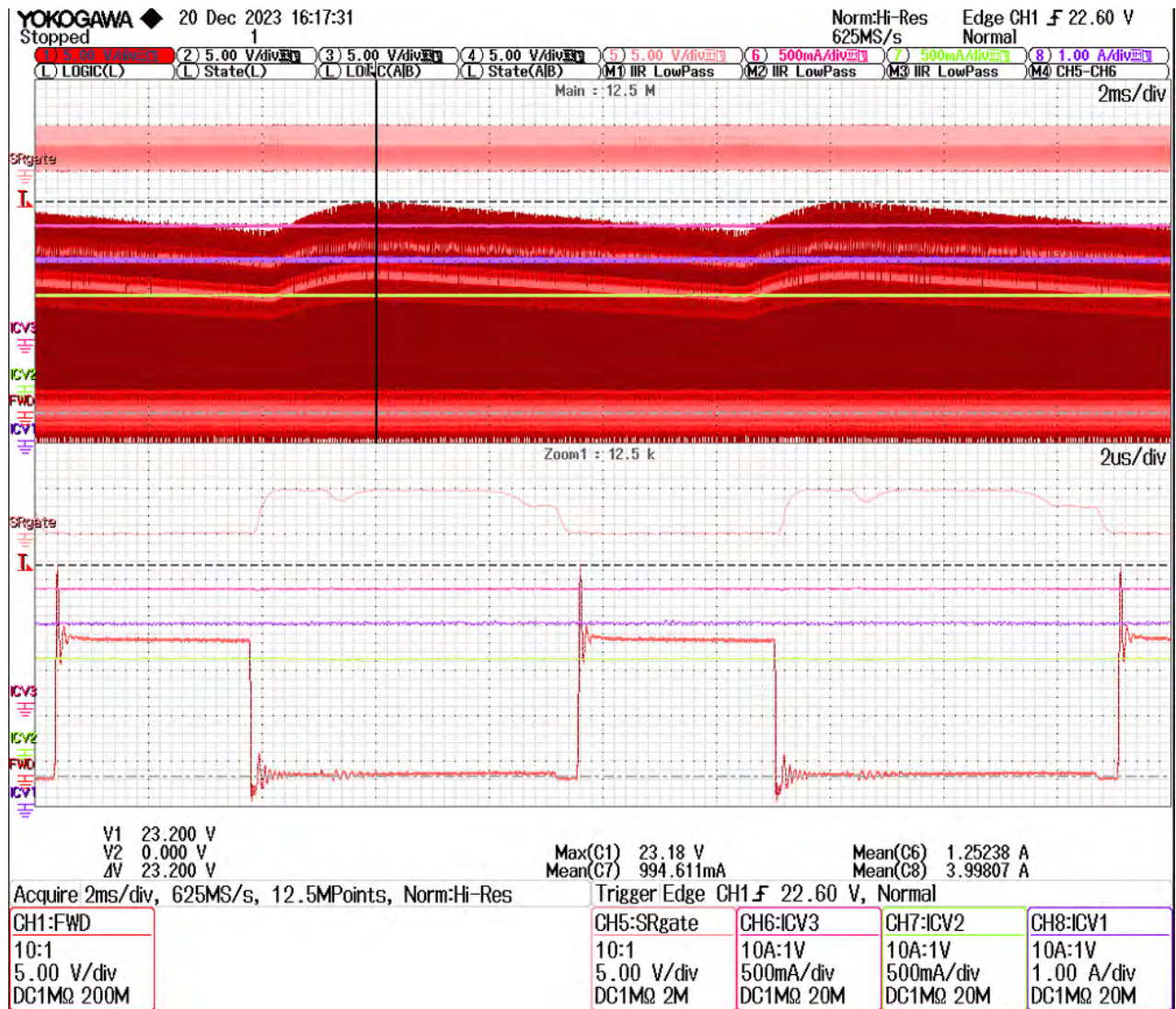

Figure 69 – SR FET(Q1)  $V_{DS}$  Voltage Under Full Load at 90 VAC.

Ch1:  $V_{SR}$ , Ch5:  $SR_{GATE}$ , Ch6:  $ICV3$ , Ch7:  $ICV2$ , Ch8:  $ICV1$

Maximum D-S voltage across the SR FET is 23 V.





Figure 70 – SR FET(Q1)  $V_{ds}$  Voltage at Start-up at 90 VAC.

Ch1:  $V_{SR}$ , Ch5:  $SR_{GATE}$ , Ch6:  $I_{CV3}$ , Ch7:  $I_{CV2}$ , Ch8:  $I_{CV1}$

Maximum D-S voltage across the SR FET 17.6 V.

9.9.2 CV1 Selection FET Drain-Source Voltage

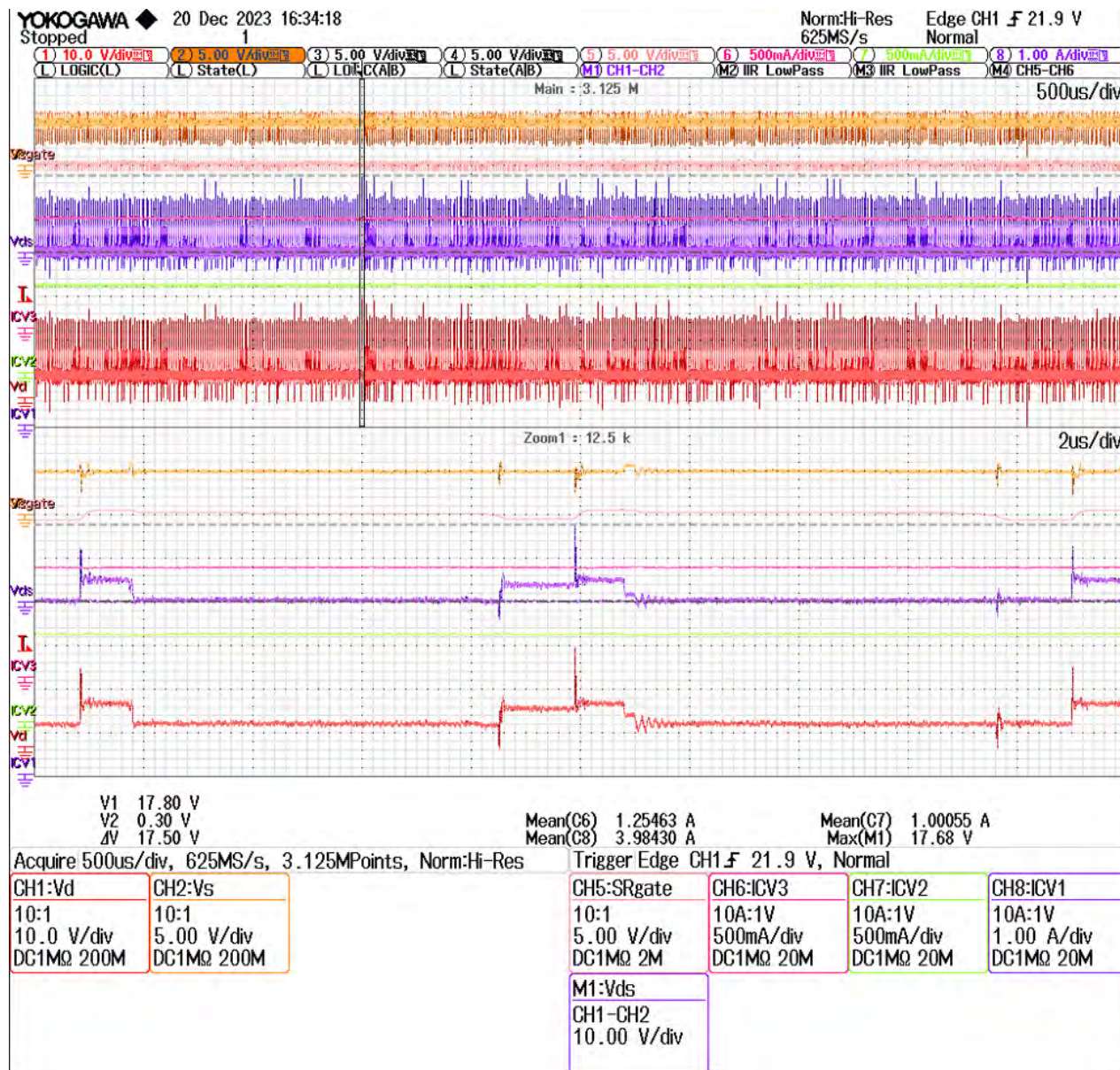

Figure 71 – CV1 Selection FET (Q2) D-S Voltage Under Full Load at 265 VAC.

Ch1:  $V_{CV1DRAIN}$ , Ch2:  $V_{CV1}$ , Ch5:  $SR_{GATE}$ ,  
 Ch6:  $I_{cV3}$ , Ch7:  $I_{cV2}$ , Ch8:  $I_{cV1}$ , ChM1:  $V_{DS\_CV1}$

The maximum D-S voltage across the selection FET of CV1 is 17.7 V.

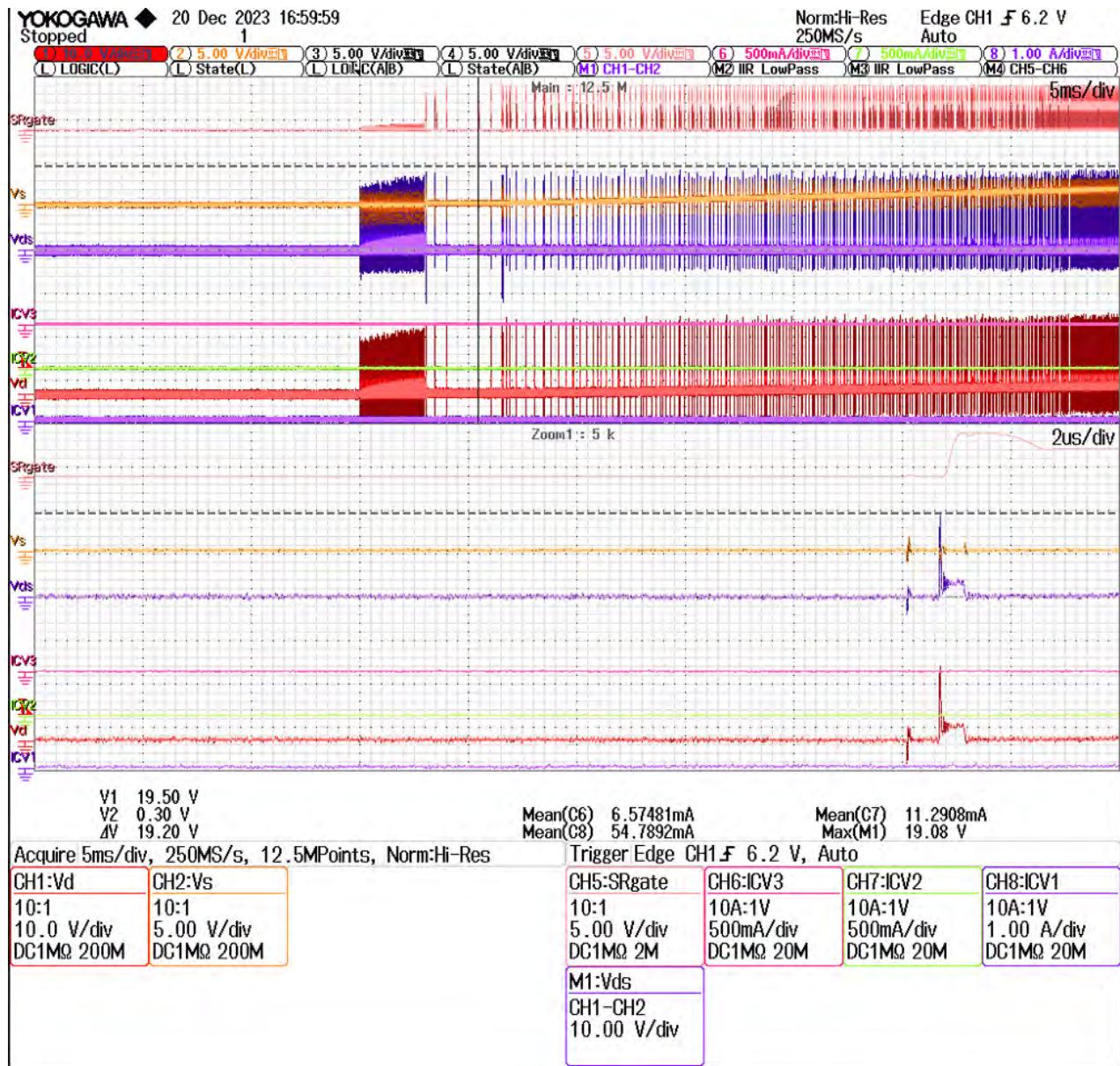
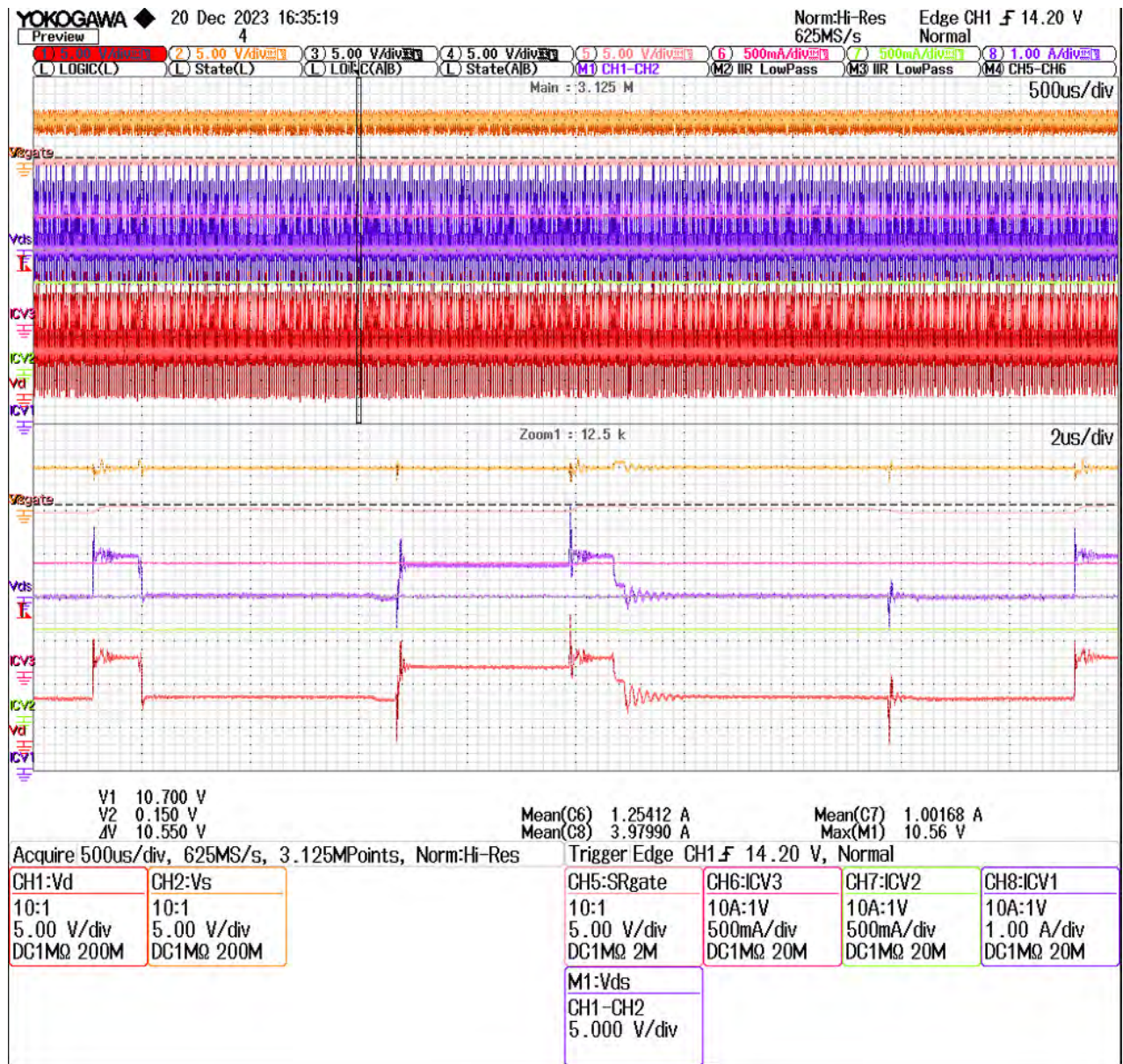

Figure 72 – CV1 Selection FET (Q2) D-S Voltage at Start-up at 265 VAC.

Ch1:  $V_{CV1DRAIAN}$ , Ch2:  $V_{CV1}$ , Ch5:  $SR_{GATE}$ ,  
 Ch6:  $I_{CV3}$ , Ch7:  $I_{CV2}$ , Ch8:  $I_{CV1}$ , ChM1:  $V_{DS\_CV1}$

The maximum D-S voltage across the selection FET of CV1 is 19.5 V.



**Figure 73** – CV1 Selection FET (Q2) D-S Voltage Under Full Load at 90 VAC.

Ch1: V<sub>CV1DRAIN</sub>, Ch2: V<sub>CV1</sub>, Ch5: S<sub>R</sub>GATE, Ch6: I<sub>CV3</sub>, Ch7: I<sub>CV2</sub>, Ch8: I<sub>CV1</sub>, ChM1: V<sub>DS\_CV1</sub>

The maximum D-S voltage across the selection FET of CV1 is 10.7 V.

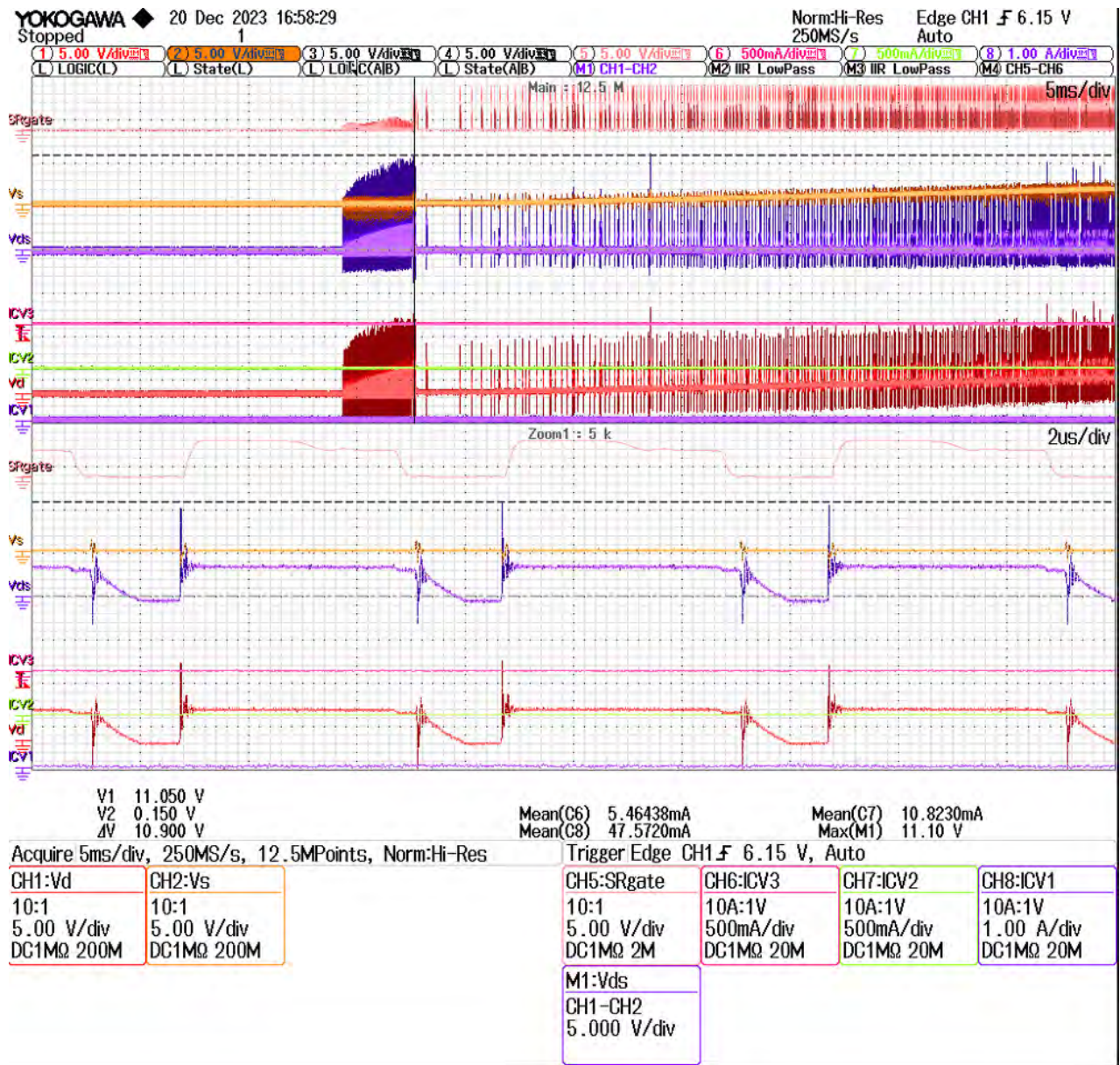

Figure 74 – CV1 Selection FET (Q2) D-S Voltage at Start-up at 90 VAC.

Ch1: V<sub>CV1DRAIN</sub>, Ch2: V<sub>CV1</sub>, Ch5: SR<sub>GATE</sub>,  
 Ch6: I<sub>CV3</sub>, Ch7: I<sub>CV2</sub>, Ch8: I<sub>CV1</sub>, ChM1: V<sub>DS\_CV1</sub>

The maximum D-S voltage across the selection FET of CV1 is 11 V.

9.9.3 CV2 Selection FET Drain-Source Voltage

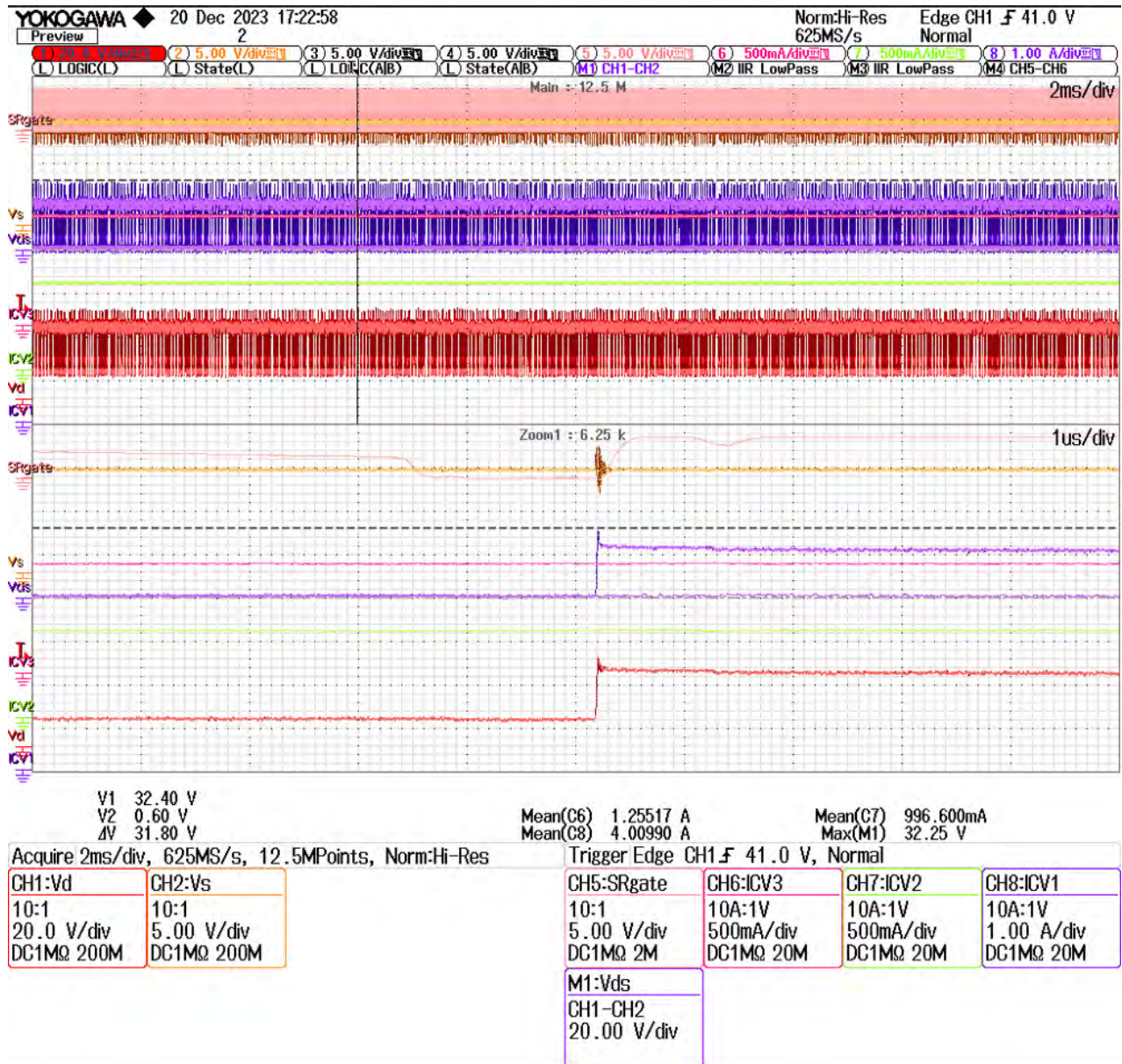

Figure 75 – CV2 Selection FET (Q4) D-S Voltage Under Full Load at 265 VAC.

Ch1:  $V_{CV2DRAIN}$ , Ch2:  $V_{CV2}$ , Ch5:  $SR_{GATE}$ ,  
 Ch6:  $I_{CV3}$ , Ch7:  $I_{CV2}$ , Ch8:  $I_{CV1}$ , ChM1:  $V_{DS\_CV2}$

The maximum D-S voltage across the selection FET of CV2 is 32.2 V.

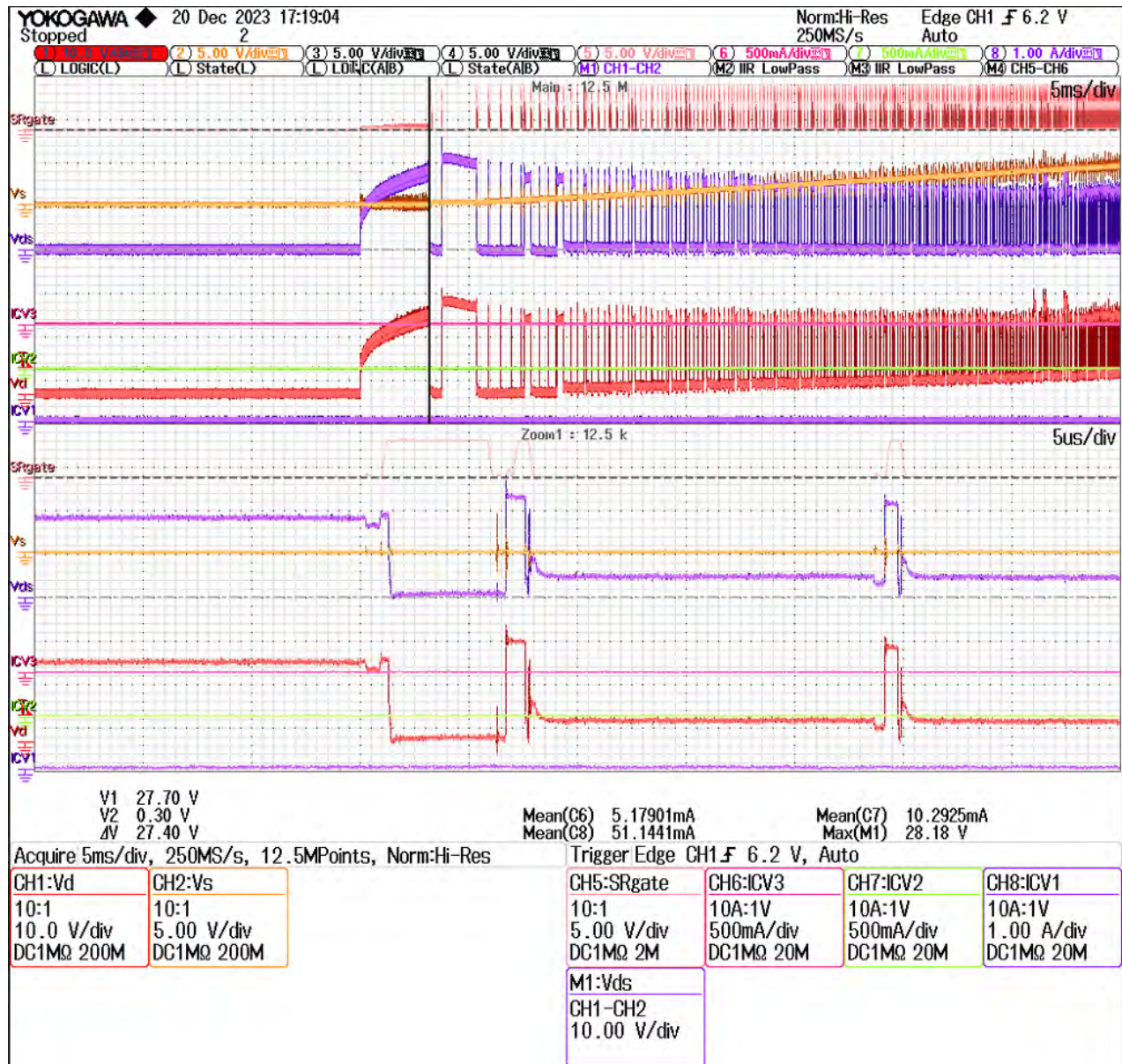

Figure 76 – CV2 Selection FET (Q4) D-S Voltage at Start-up at 265 VAC.

Ch1:  $V_{CV2\text{drain}}$ , Ch2:  $V_{CV2}$ , Ch5:  $SR_{GATE}$ ,  
 Ch6:  $I_{CV3}$ , Ch7:  $I_{CV2}$ , Ch8:  $I_{CV1}$ , ChM1:  $V_{DS\_CV2}$

The maximum D-S voltage across the selection FET of CV2 is 28.2 V.

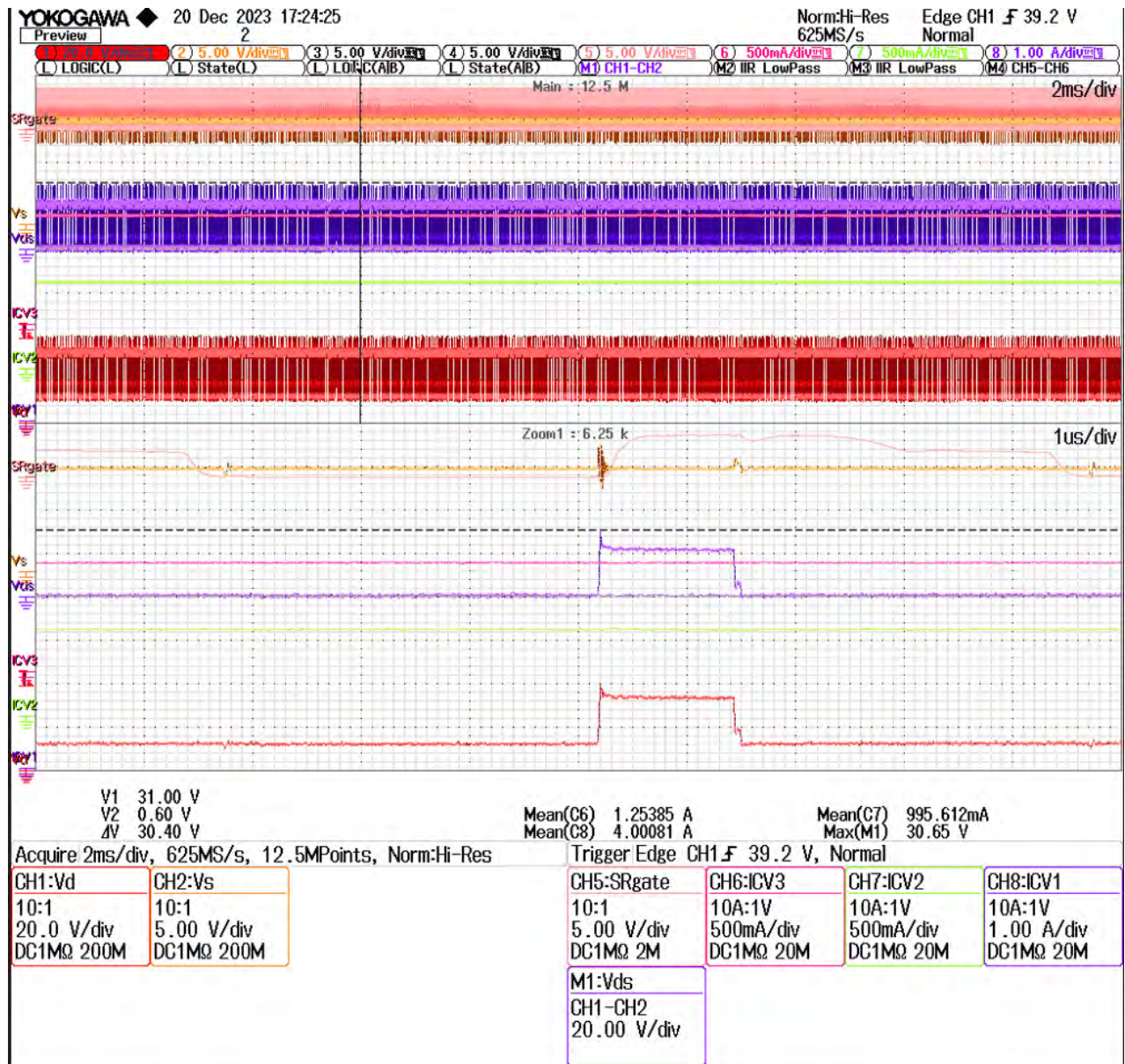

Figure 77 – CV2 Selection FET (Q4) D-S Voltage Under Full Load at 90 VAC.

Ch1:  $V_{CV2DRAIN}$ , Ch2:  $V_{CV2}$ , Ch5:  $SR_{GATE}$ ,  
Ch6:  $I_{CV3}$ , Ch7:  $I_{CV2}$ , Ch8:  $I_{CV1}$ , ChM1:  $V_{DS\_CV2}$

The maximum D-S voltage across the selection FET of CV2 is 30.7 V.



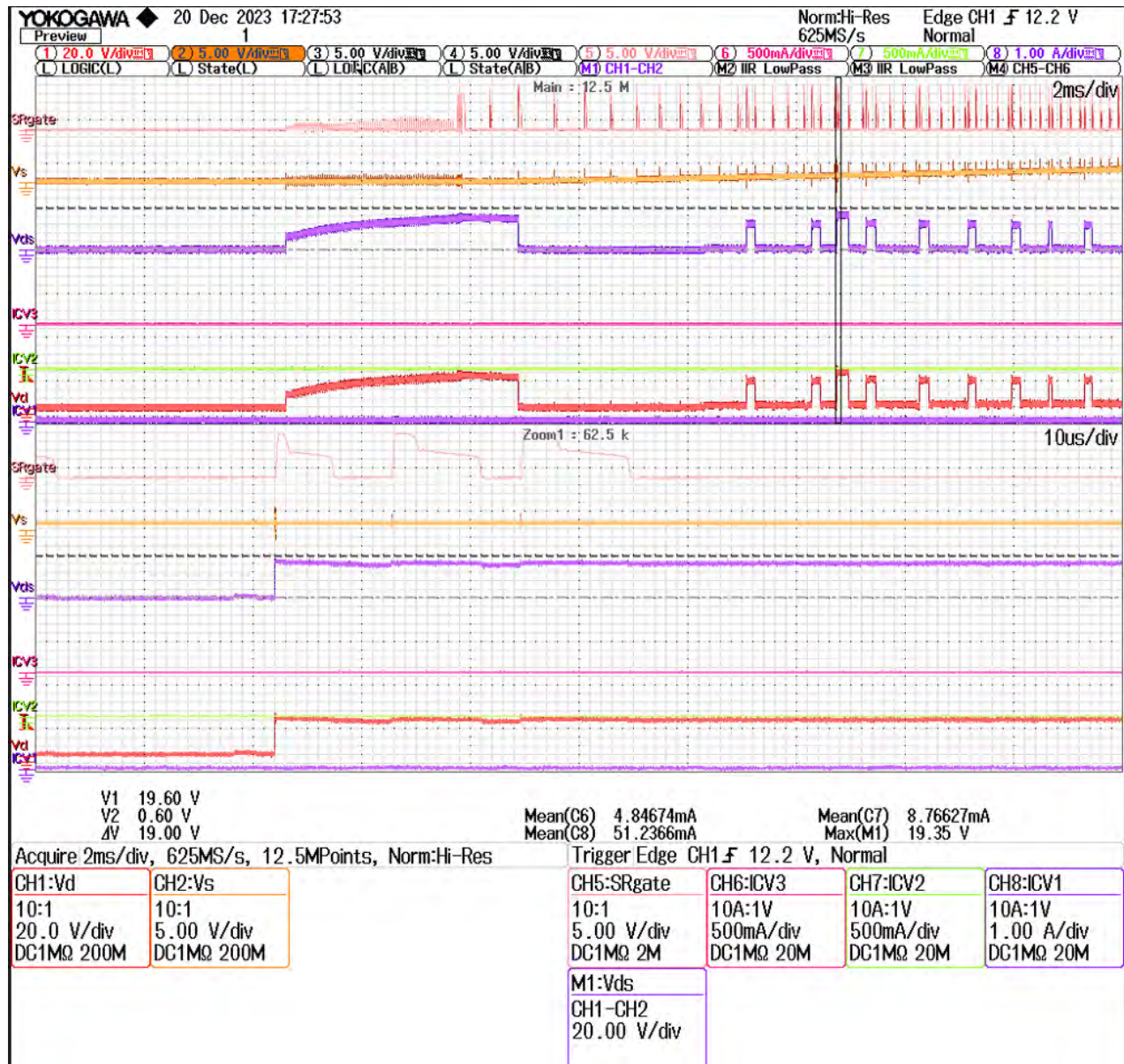

Figure 78 – CV2 Selection FET (Q4) D-S Voltage at Start-up at 90 VAC.

Ch1: V<sub>CV2DRAIN</sub>, Ch2: V<sub>CV2</sub>, Ch5: SR<sub>GATE</sub>,  
 Ch6: I<sub>CV3</sub>, Ch7: I<sub>CV2</sub>, Ch8: I<sub>CV1</sub>, ChM1: V<sub>DS\_CV2</sub>

The maximum D-S voltage across the selection FET of CV2 is 19.3 V.

9.9.4 CV2 Rectifier Diode Reverse Voltage

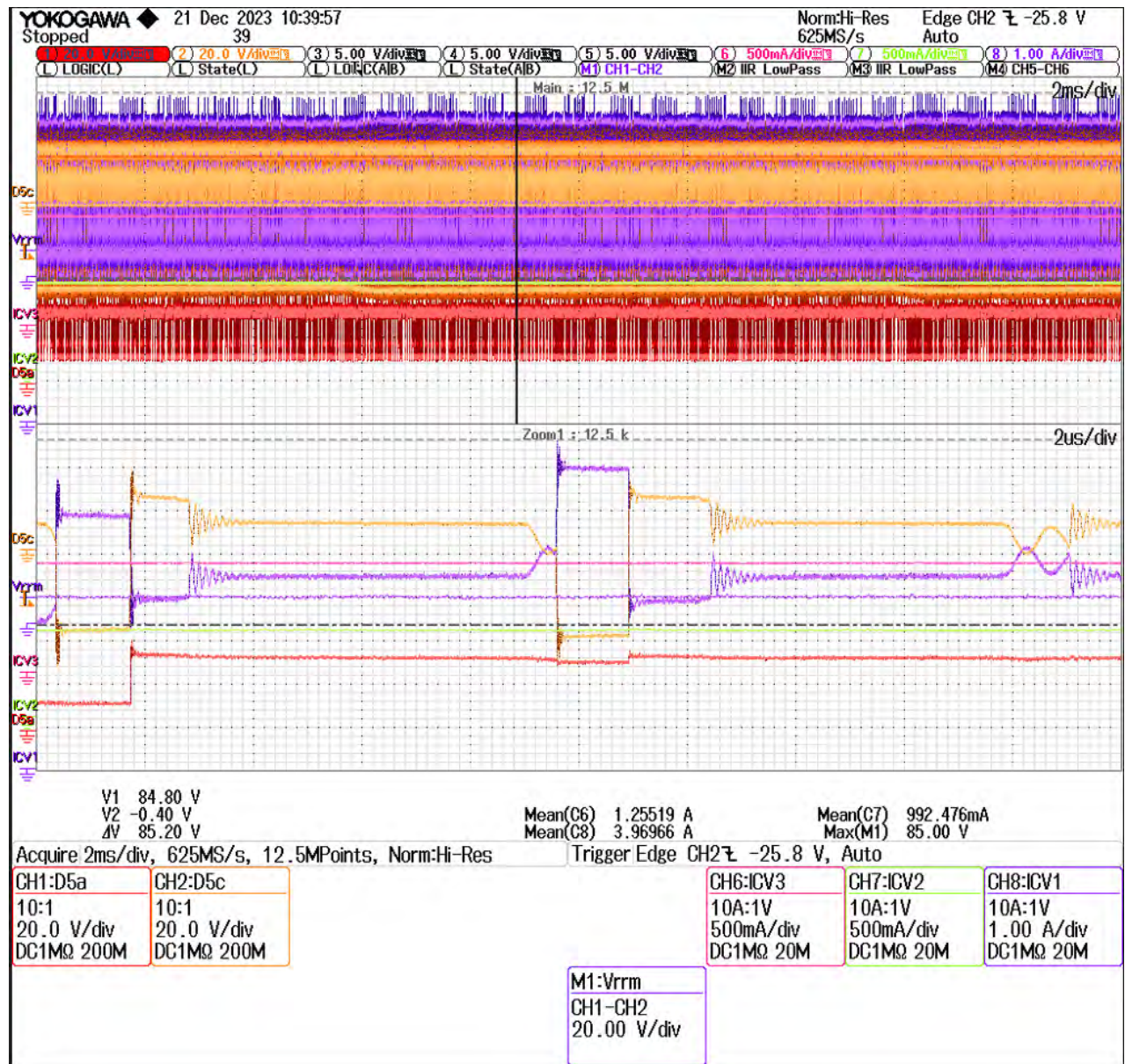

Figure 79 – CV2 Rectifier Diode Reverse Voltage Under Full Load at 265 VAC.

Ch1: D5<sub>A</sub>, Ch2: D5<sub>C</sub>, Ch6: I<sub>CV3</sub>, Ch7: I<sub>CV2</sub>, Ch8: I<sub>CV1</sub>, M1: V<sub>RRM</sub>

Maximum reverse voltage across the CV2 rectifier diode is 85 V.

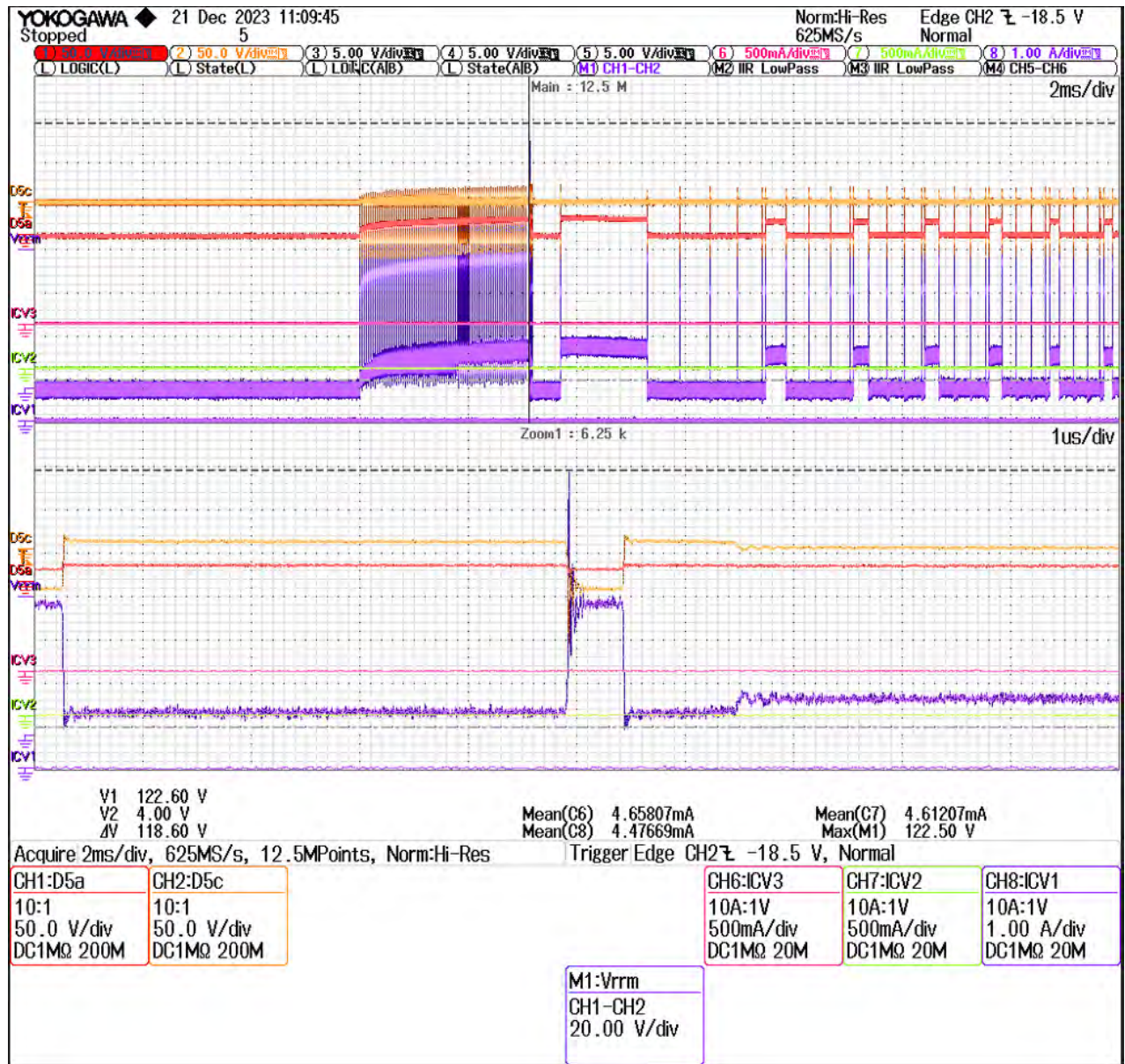
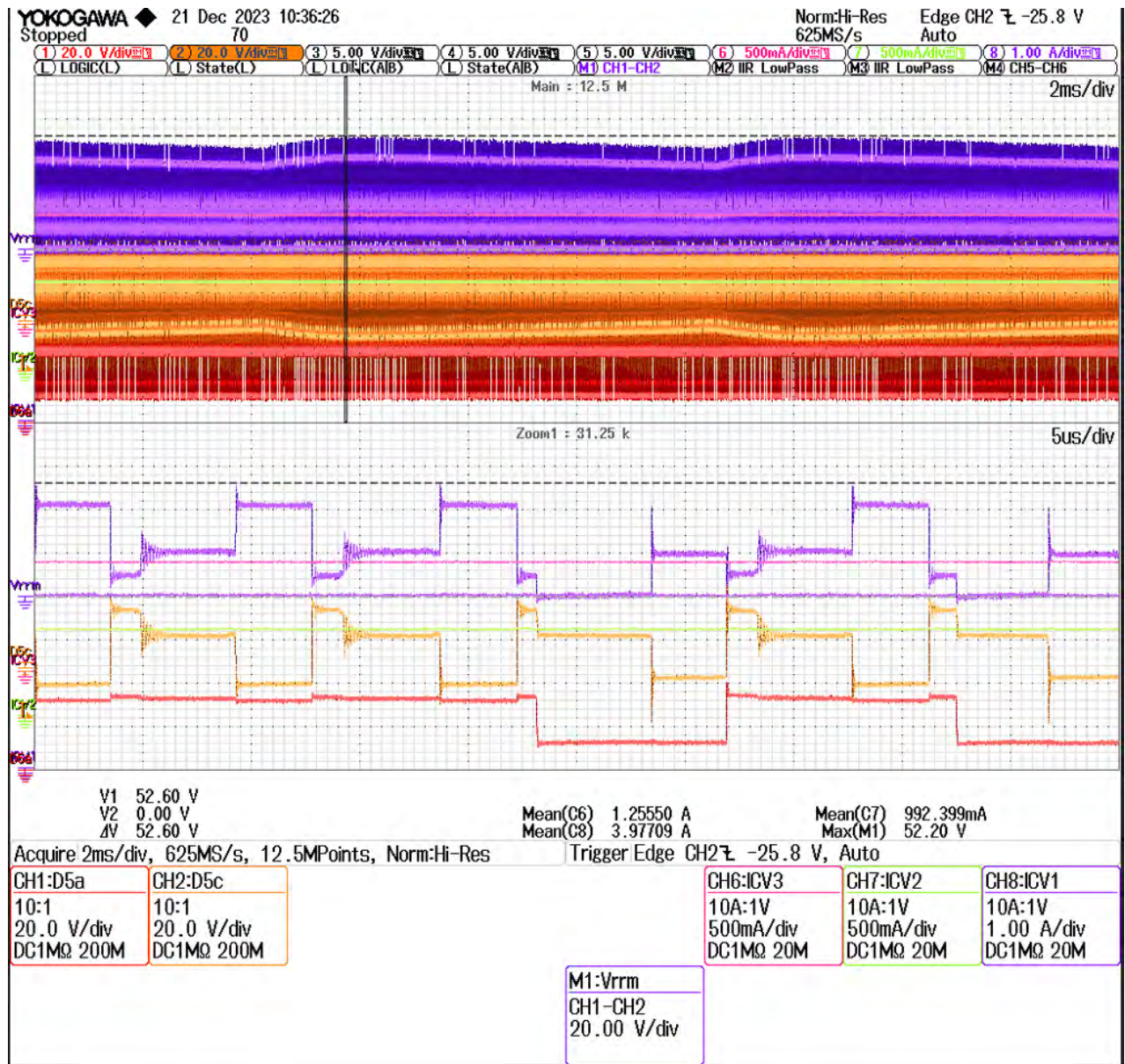

Figure 80 – CV2 Rectifier Diode Reverse Voltage at Start-up at 265 VAC.

Ch1: D5A, Ch2: D5C, Ch6: ICV3, Ch7: ICV2, Ch8: ICV1, M1: VRRM

Maximum reverse voltage across the CV2 rectifier diode is 123 V.



**Figure 81** – CV2 Rectifier Diode Reverse Voltage Under Full Load at 90 VAC.

Ch1: D5<sub>A</sub>, Ch2: D5<sub>C</sub>, Ch6: I<sub>CV3</sub>, Ch7: I<sub>CV2</sub>, Ch8: I<sub>CV1</sub>, M1: V<sub>RRM</sub>

Maximum reverse voltage across the CV2 rectifier diode is 52 V.

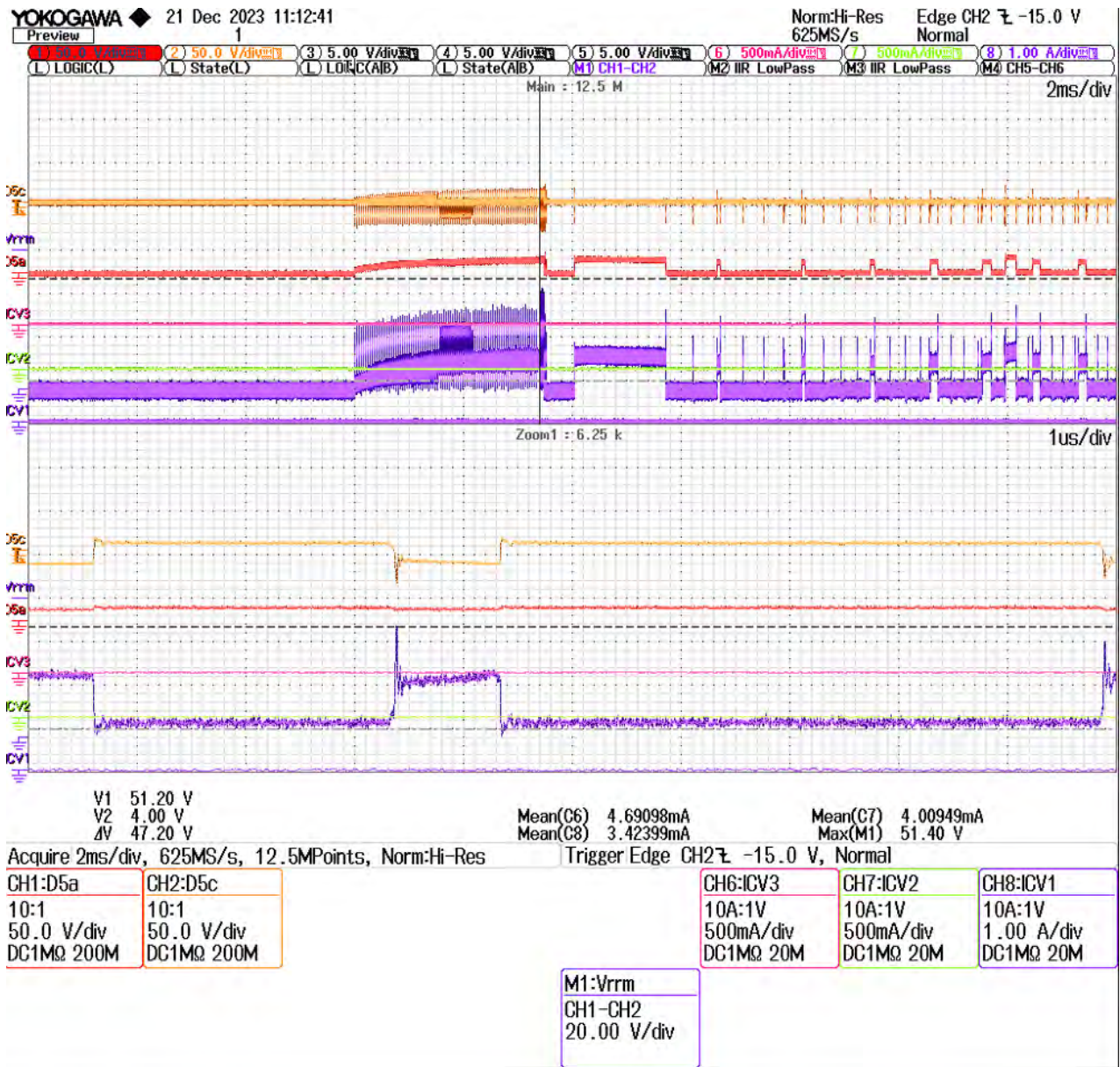

**Figure 82** – CV2 Rectifier Diode Reverse Voltage at Start-up at 90 VAC.

Ch1: D5<sub>A</sub>, Ch2: D5<sub>C</sub>, Ch6: I<sub>CV3</sub>, Ch7: I<sub>CV2</sub>, Ch8: I<sub>CV1</sub>, M1: V<sub>RRM</sub>

Maximum reverse voltage across the CV2 rectifier diode is 51 V.

9.9.5 CV3 Rectifier Diode Reverse Voltage

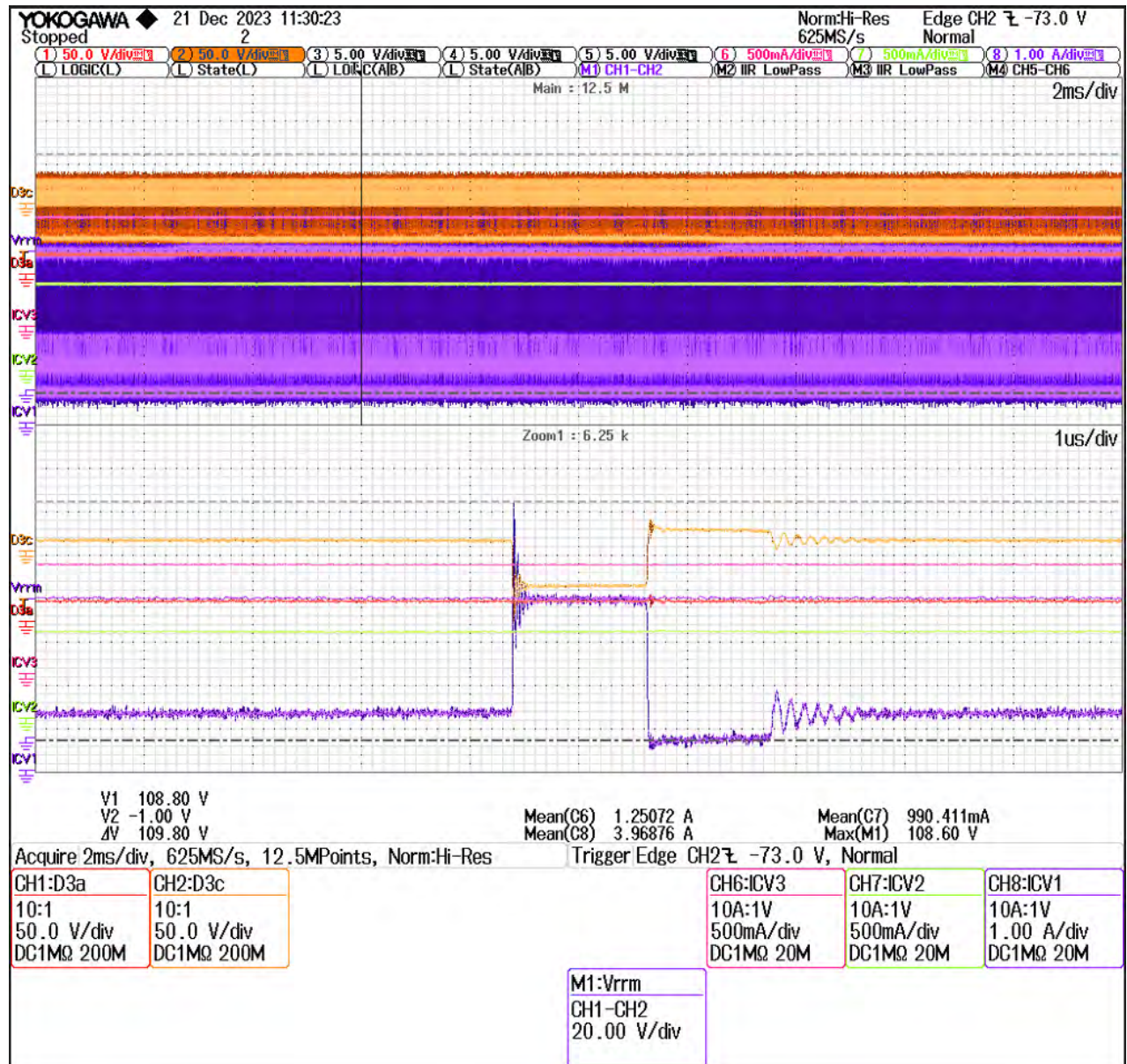

Figure 83 – CV3 Rectifier Diode Reverse Voltage Under Full Load at 265 VAC.  
 Ch1: D3<sub>A</sub>, Ch2: D3<sub>C</sub>, Ch6: ICV<sub>3</sub>, Ch7: ICV<sub>2</sub>, Ch8: ICV<sub>1</sub>, M1: V<sub>RRM</sub>

Maximum reverse voltage across the CV2 rectifier diode is 109 V.

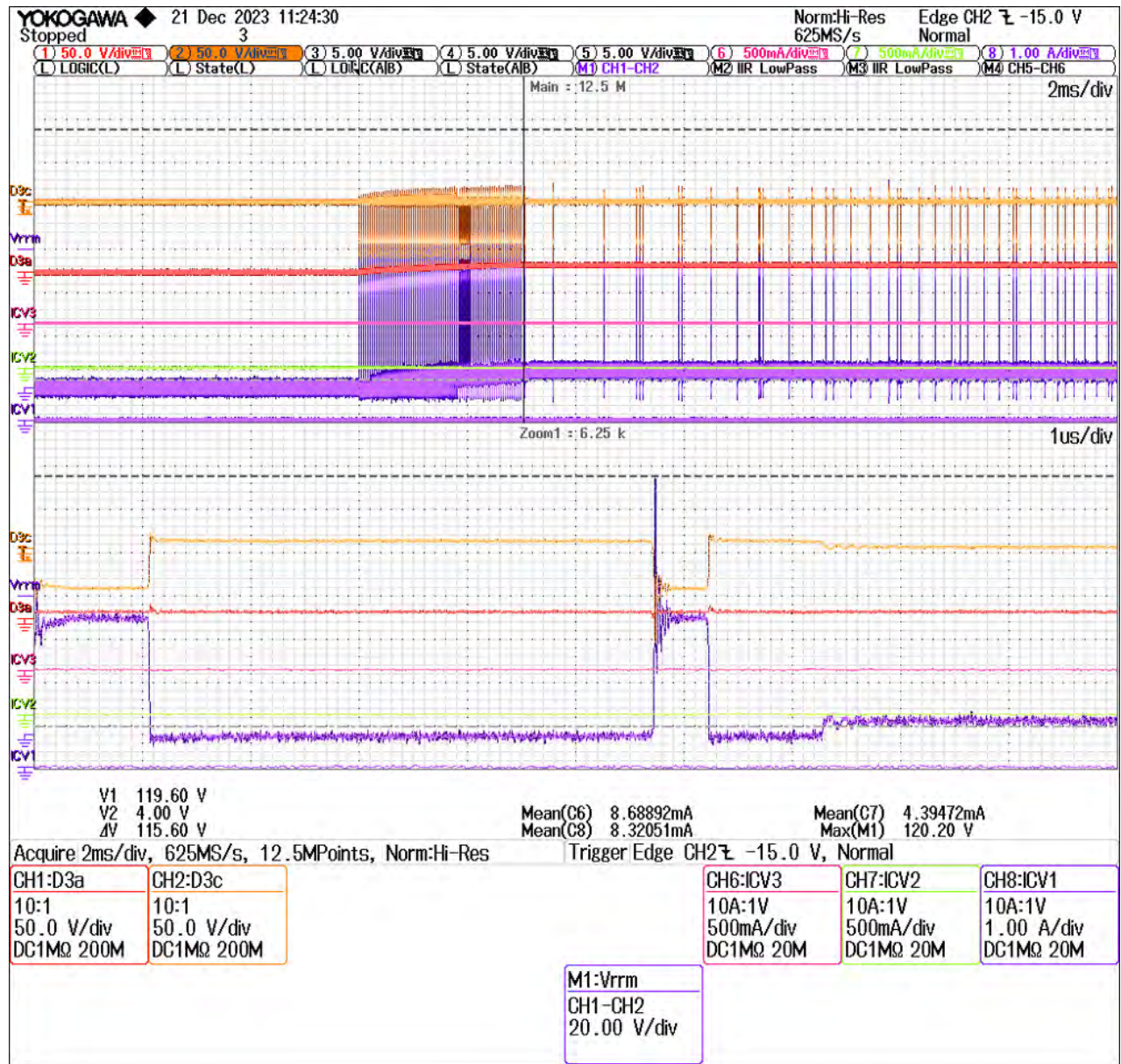

Figure 84 – CV3 Rectifier Diode Reverse Voltage at Start-up at 265 VAC.

Ch1: D3A, Ch2: D3C, Ch6: ICV3, Ch7: ICV2, Ch8: ICV1, M1: V<sub>RRM</sub>

Maximum reverse voltage across the CV2 rectifier diode is 120 V.

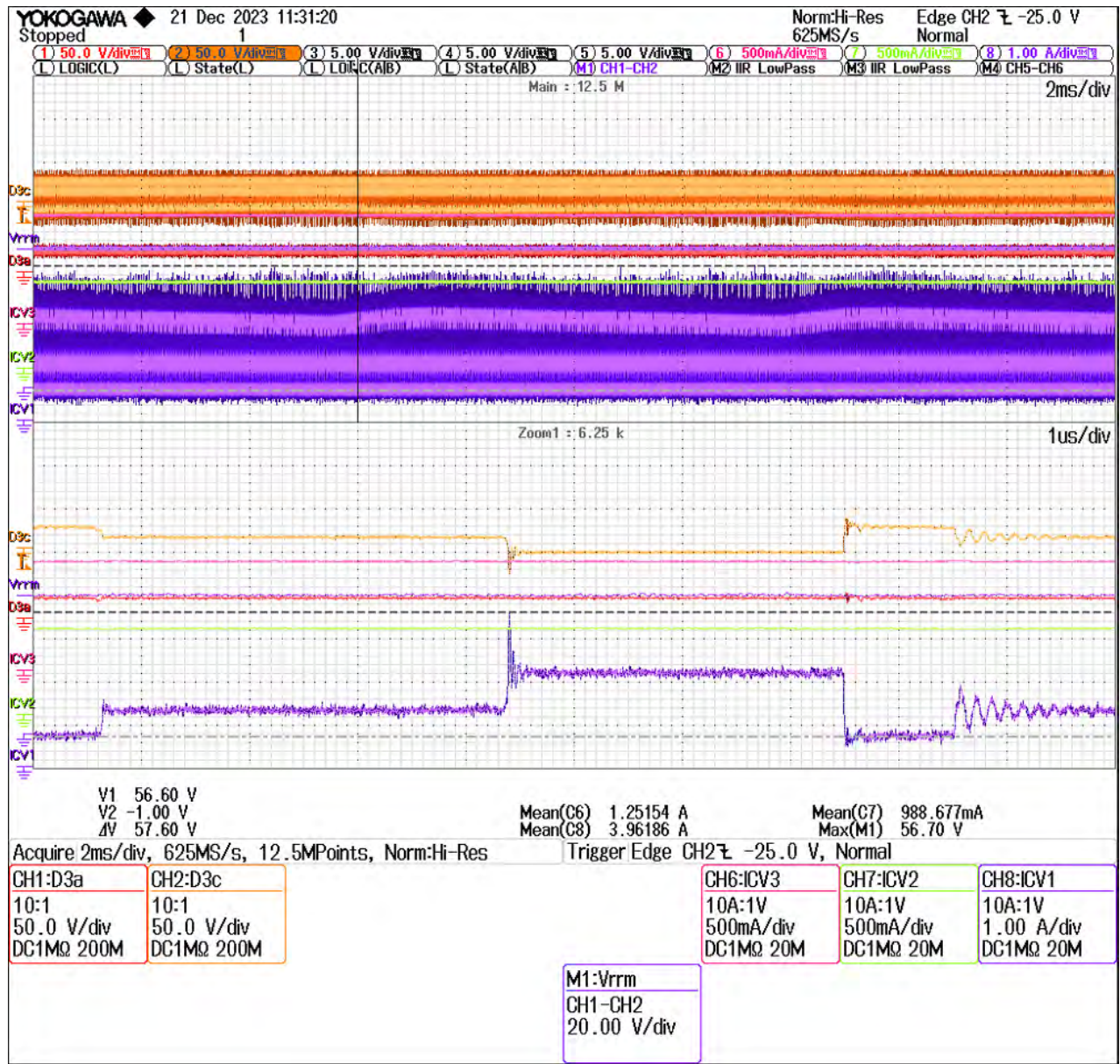

Figure 85 – CV3 Rectifier Diode Reverse Voltage Under Full Load at 90 VAC.

Ch1: D3A, Ch2: D3C, Ch6: Icv3, Ch7: Icv2, Ch8: Icv1, M1: V<sub>RRM</sub>

Maximum reverse voltage across the CV2 rectifier diode is 57 V.



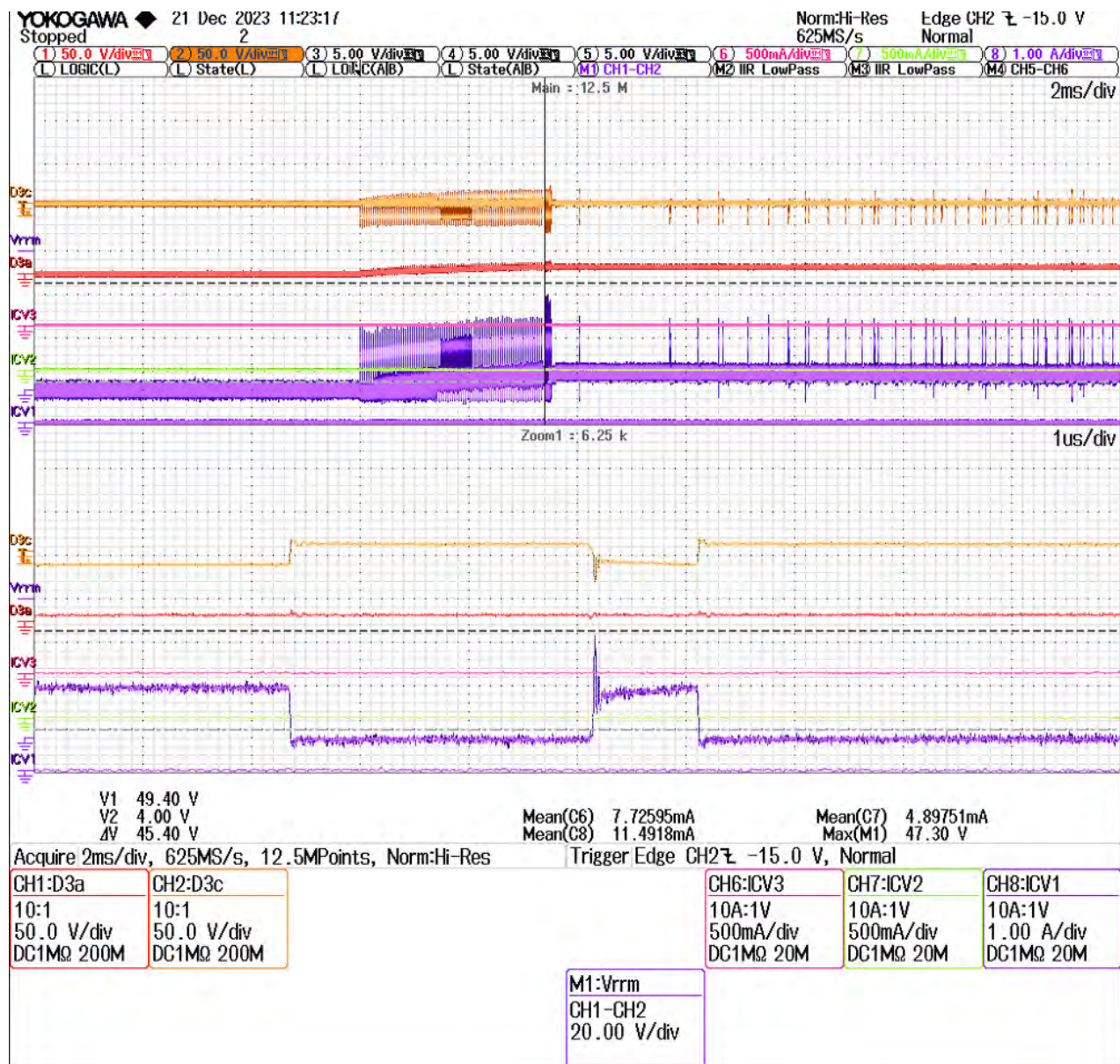

Figure 86 – CV3 Rectifier Diode Reverse Voltage at Start-up at 90 VAC.

Ch1: D3<sub>A</sub>, Ch2: D3<sub>C</sub>, Ch6: I<sub>CV3</sub>, Ch7: I<sub>CV2</sub>, Ch8: I<sub>CV1</sub>, M1: V<sub>RRM</sub>

Maximum reverse voltage across the CV2 rectifier diode is 47 V.

9.9.6 Bias Winding Rectifier Diode Reverse Voltage

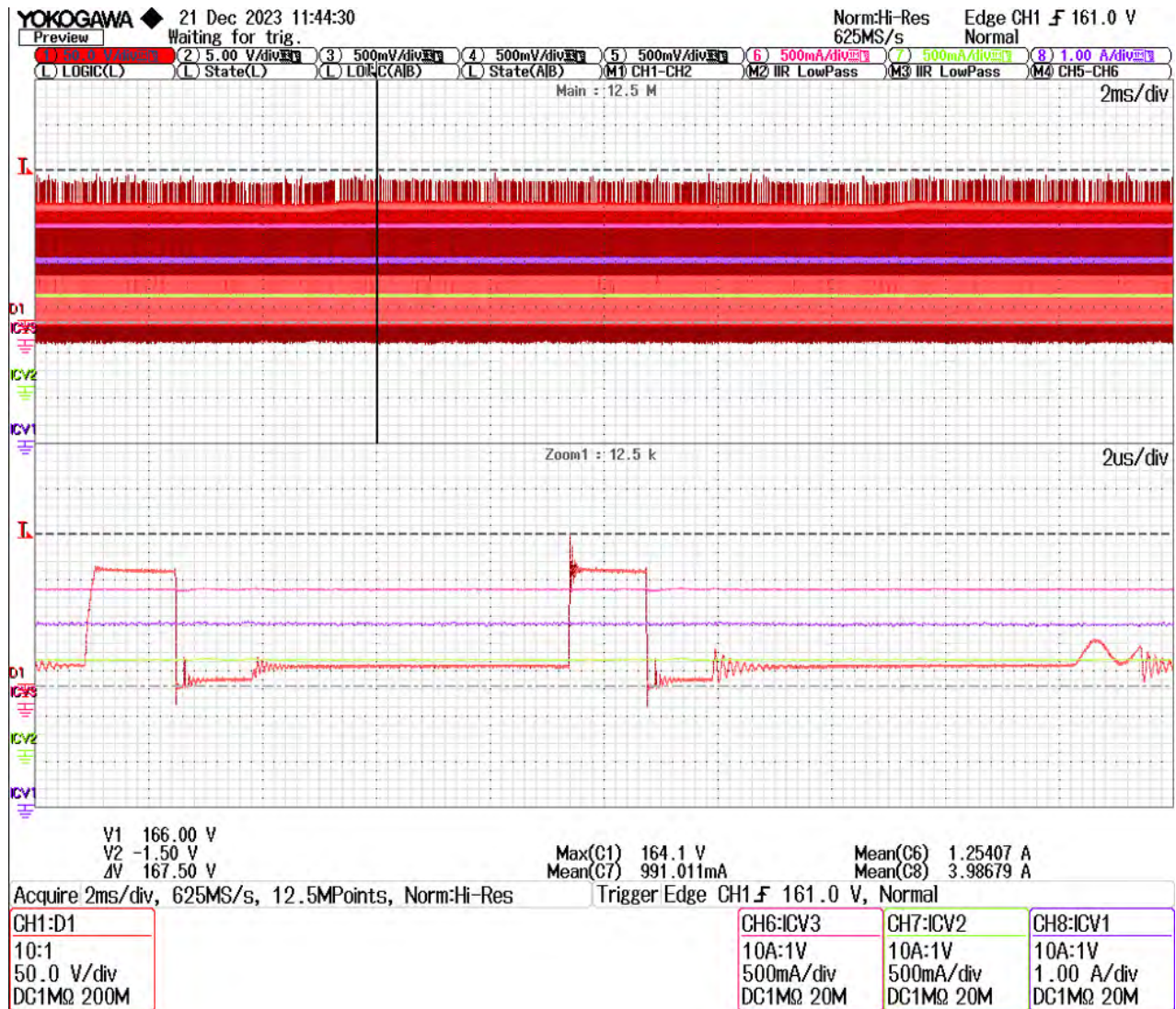

Figure 87 – AUX Rectifier Diode Reverse Voltage Under Full Load at 265 VAC.

Ch1: D1<sub>RRM</sub>, Ch6: I<sub>CV3</sub>, Ch7: I<sub>CV2</sub>, Ch8: I<sub>CV1</sub>

Maximum reverse voltage across the AUX winding rectifier diode is 166 V.

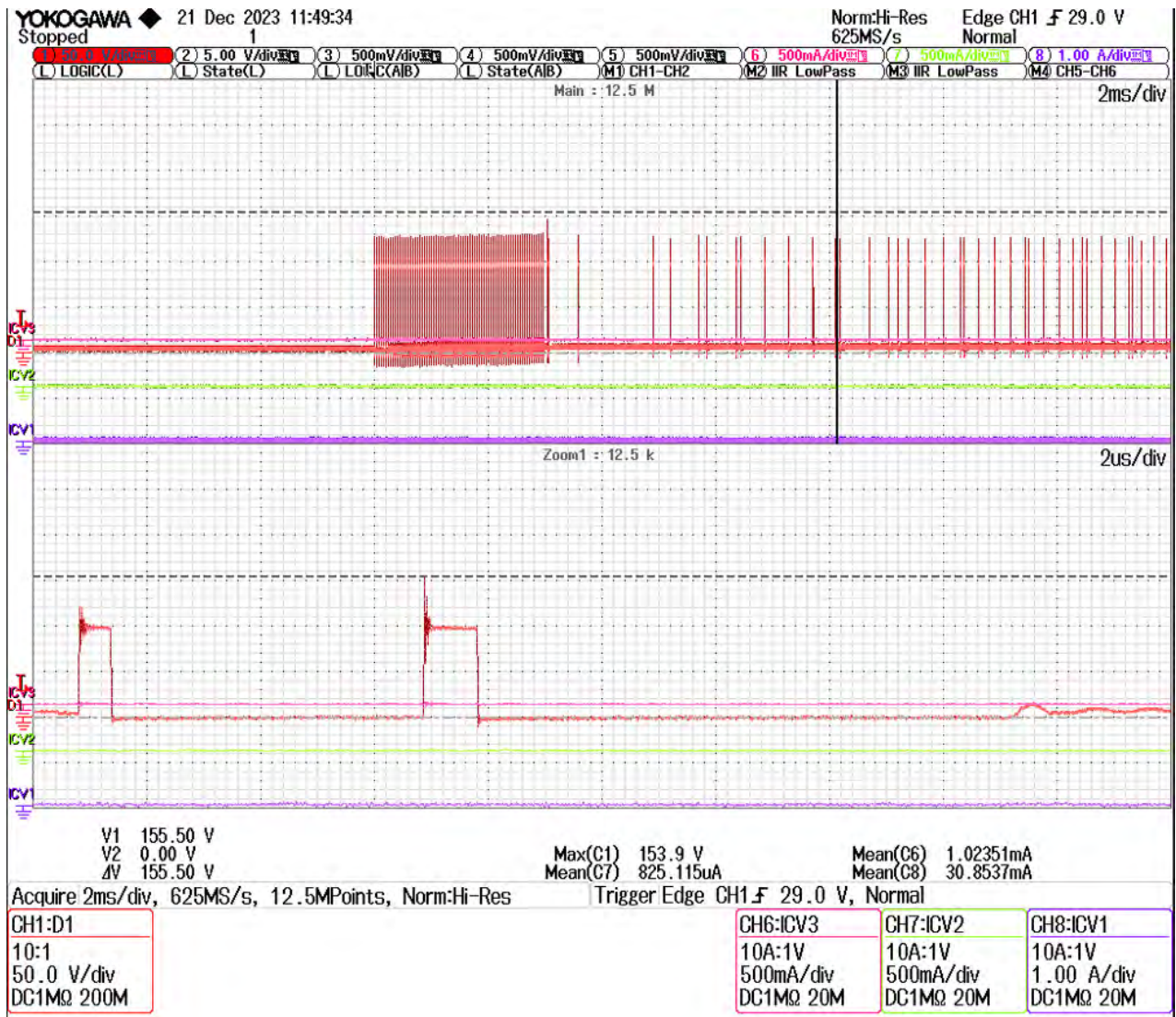

Figure 88 – AUX Rectifier Diode Reverse Voltage at Start-up at 265 VAC.

Ch1: D1<sub>RMM</sub>, Ch6: I<sub>CV3</sub>, Ch7: I<sub>CV2</sub>, Ch8: I<sub>CV1</sub>

Maximum reverse voltage across the AUX winding rectifier diode is 154 V.



Figure 89 – AUX Rectifier Diode Reverse Voltage Under Full Load at 90 VAC.

Ch1: D1<sub>RMM</sub>, Ch6: ICV3, Ch7: ICV2, Ch8: ICV1

Maximum reverse voltage across the AUX winding rectifier diode is 94 V.



Figure 90 – AUX Rectifier Diode Reverse Voltage at Start-up at 90 VAC.

Ch1: D1<sub>RRM</sub>, Ch6: I<sub>CV3</sub>, Ch7: I<sub>CV2</sub>, Ch8: I<sub>CV1</sub>

Maximum reverse voltage across the AUX winding rectifier diode is 61 V.

### 9.10 Brown-Out and Brown-In

The brown-in and brown-out results were measured at full load on all outputs. The results are shown in the table below. Screenshots illustrating the tests are shown in Figures 88 and 89.

Brown-Out Threshold	Brown-In Threshold
[V <sub>RMS</sub> ]	[V <sub>RMS</sub> ]
63	73.4

Brown-In and Brown-Out Thresholds at Full power.

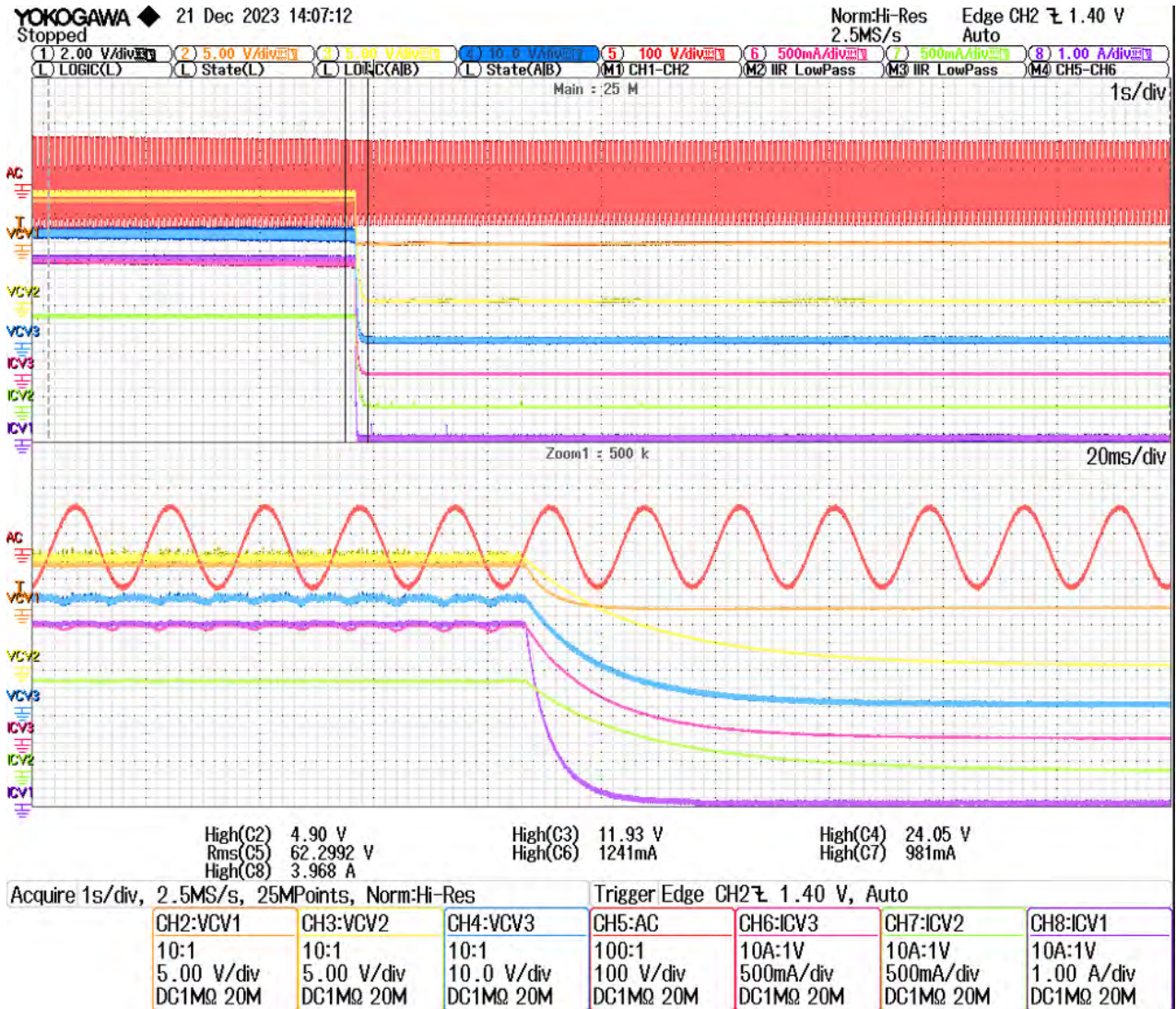

Figure 91 – Brown-Out Response at Full Power.

Ch2: V<sub>CV1</sub>, Ch3: V<sub>CV2</sub>, Ch4: V<sub>CV3</sub>, Ch5: V<sub>AC</sub>, Ch6: I<sub>CV3</sub>, Ch7: I<sub>CV2</sub>, Ch8: I<sub>CV1</sub>

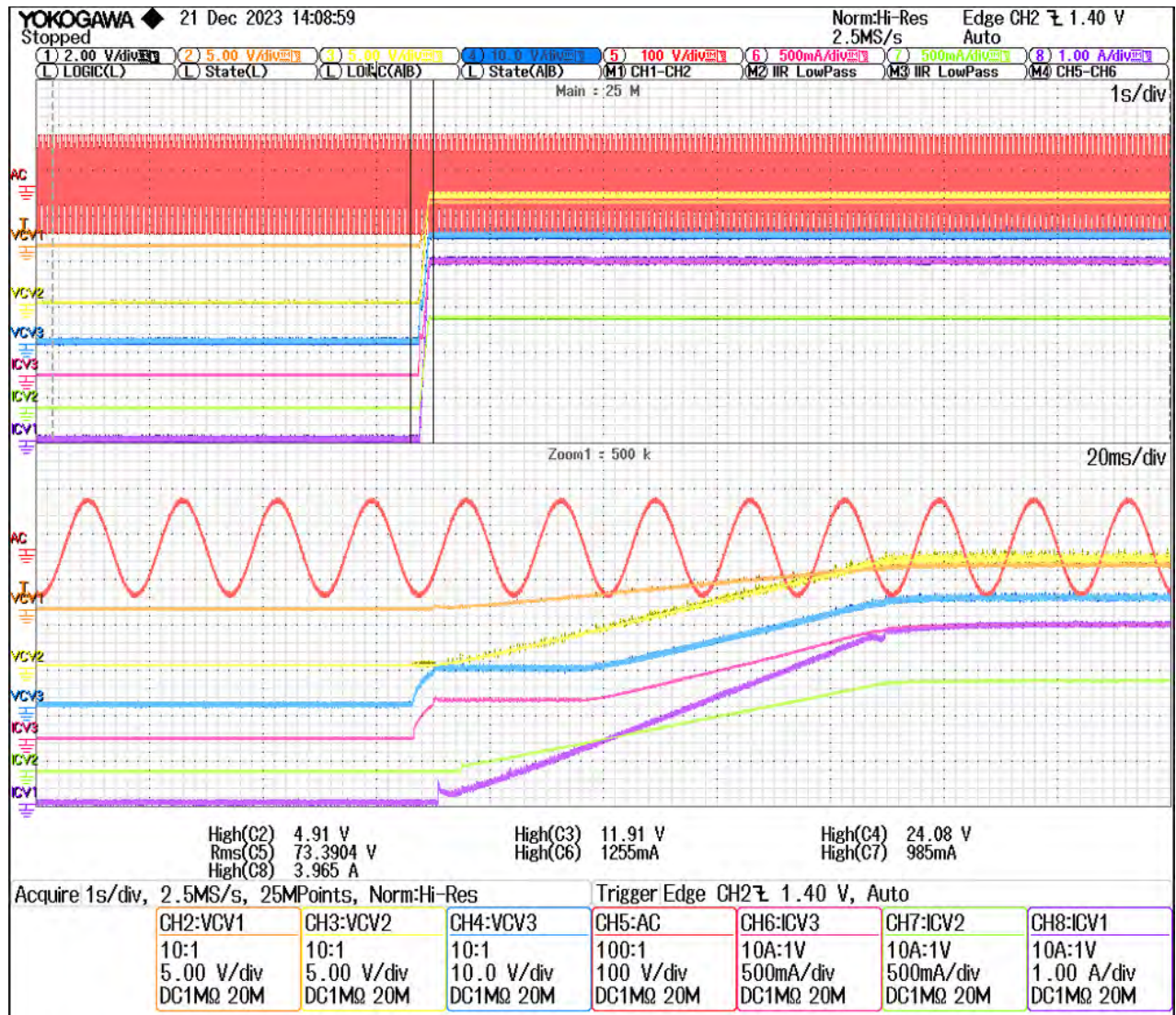

Figure 92 – Brown-In Response at Full Power.

Ch2: V<sub>CV1</sub>, Ch3: V<sub>CV2</sub>, Ch4: V<sub>CV3</sub>, Ch5: V<sub>AC</sub>, Ch6: I<sub>CV3</sub>, Ch7: I<sub>CV2</sub>, Ch8: I<sub>CV1</sub>

### 9.11 Output Protections

#### 9.11.1 CV Output Overvoltage Protection

The overvoltage protection threshold of the CV outputs was tested. Additional charge was injected into the output filter capacitor of the output under test until the converter went into a restart. The test was carried out at line voltages 90 V with full and no-load conditions.

In all cases of CV no-load and full-load, OV protection disables the system.

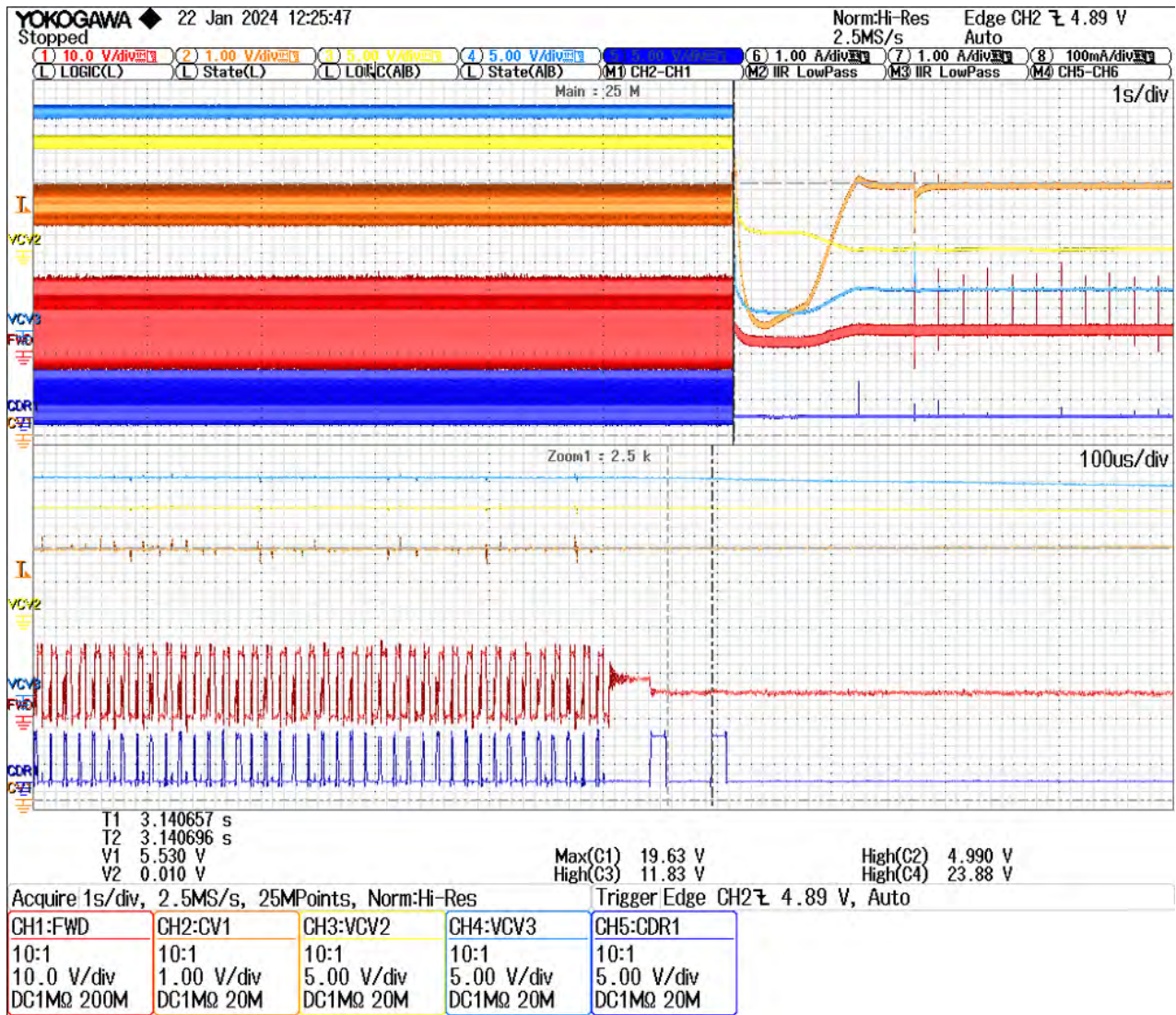

Figure 93 – CV1 OVP at Full CV2 and CV3 Load.



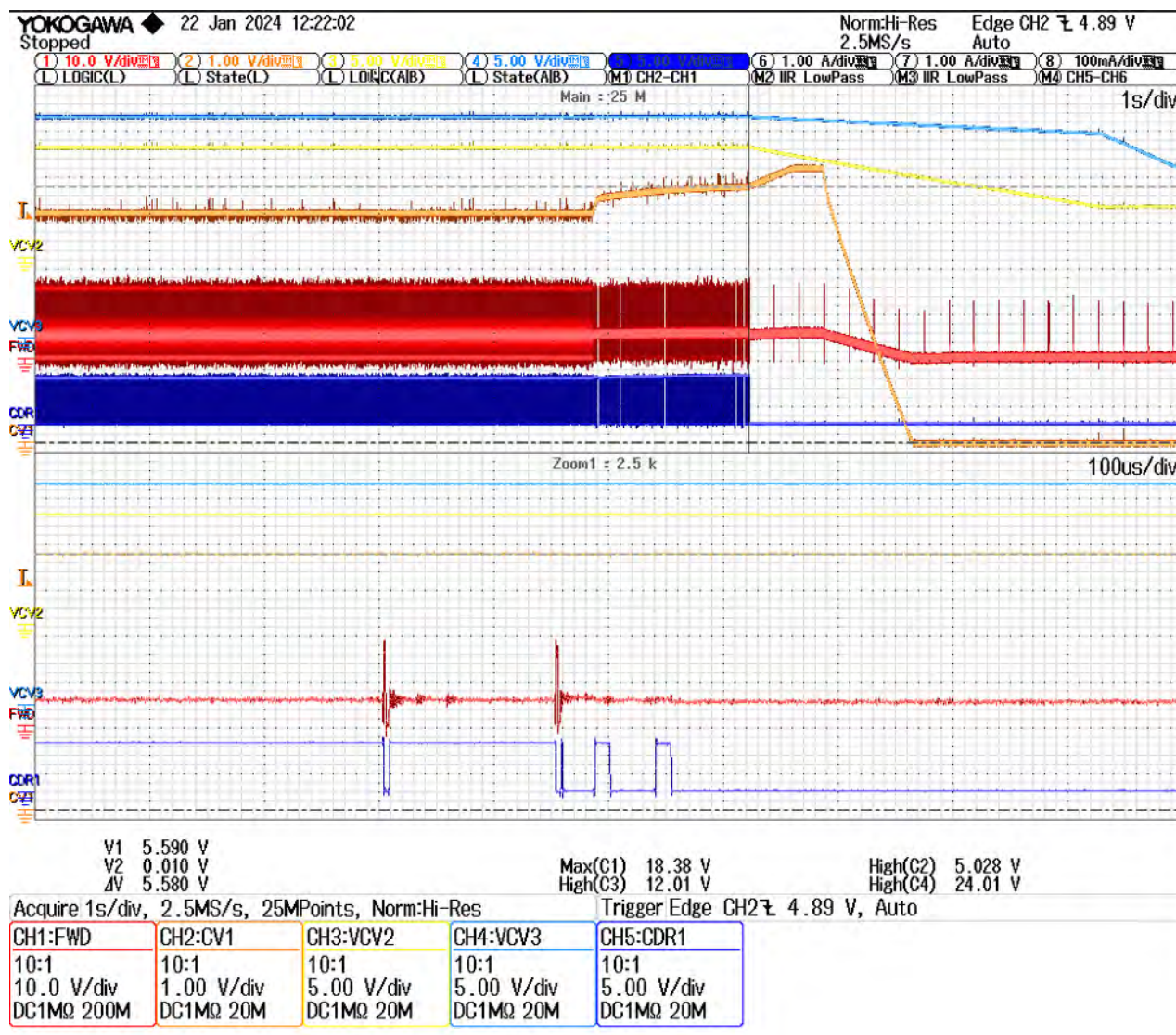

Figure 94 – CV1 OVP at No CV2 and CV3 Load.

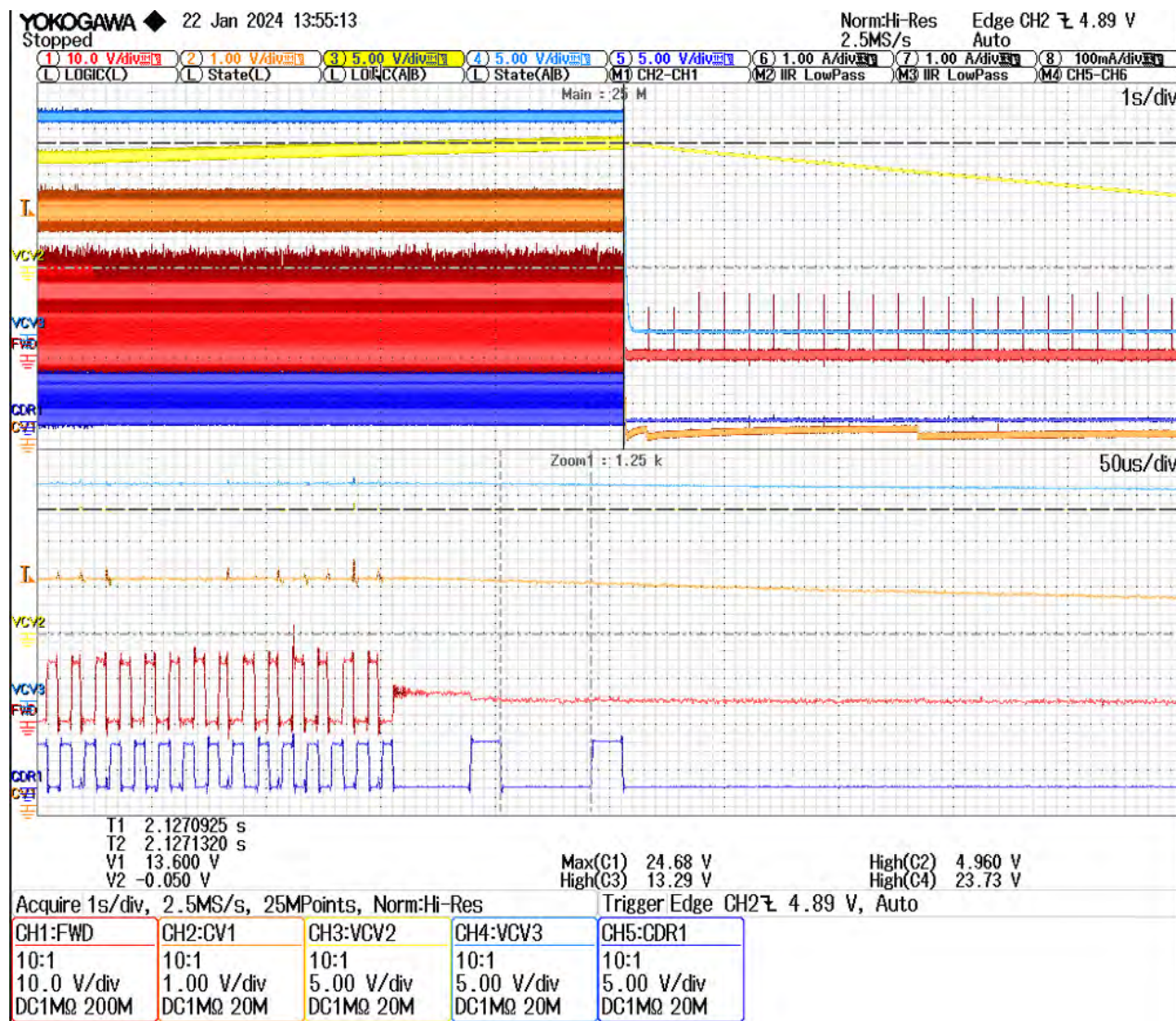

Figure 95 – CV2 OVP at Full CV1 and CV3 Load.

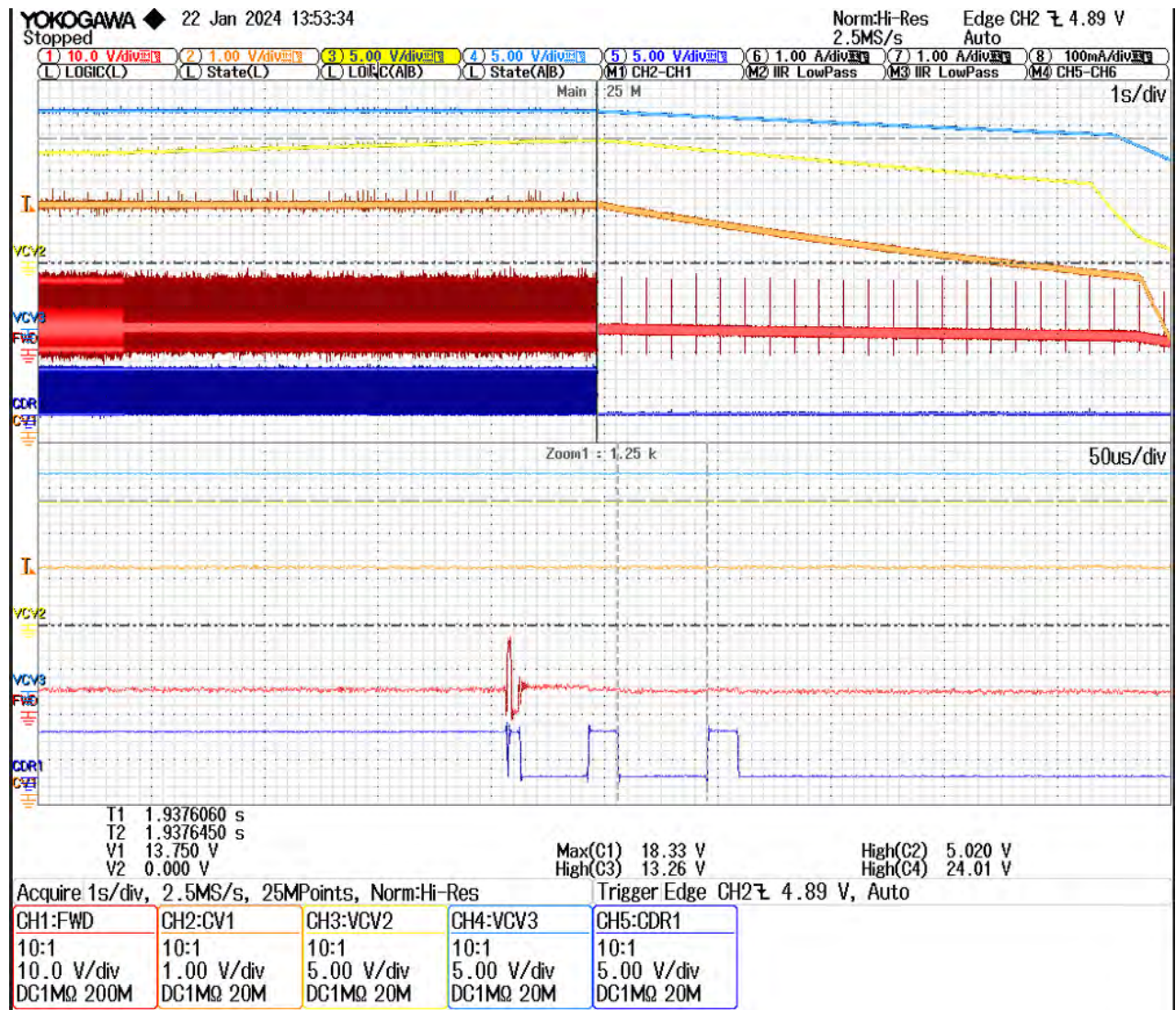

Figure 96 – CV2 OVP at No CV1 and CV3 Load.

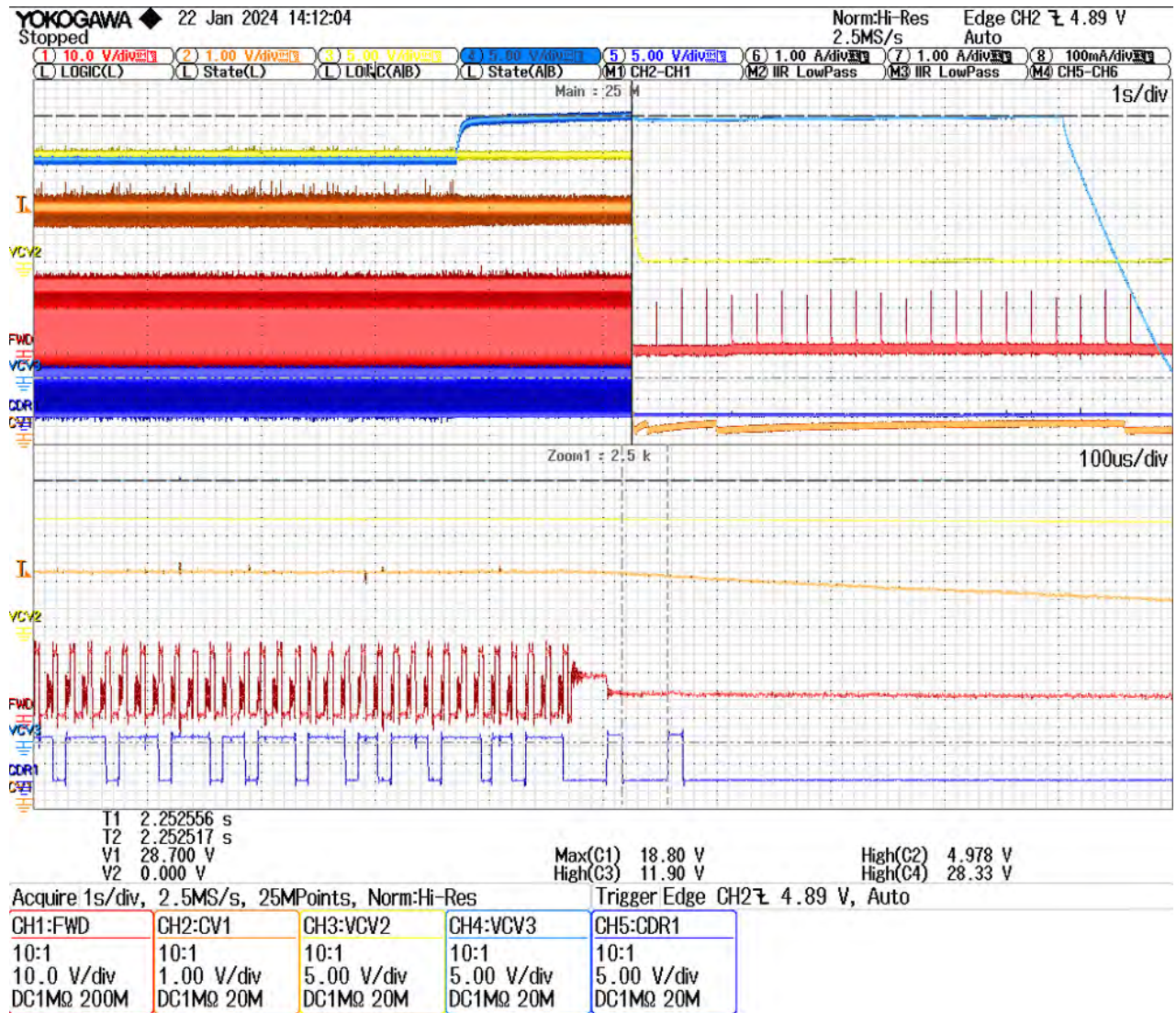

Figure 97 – CV3 OVP at Full CV1 and CV2 Load.

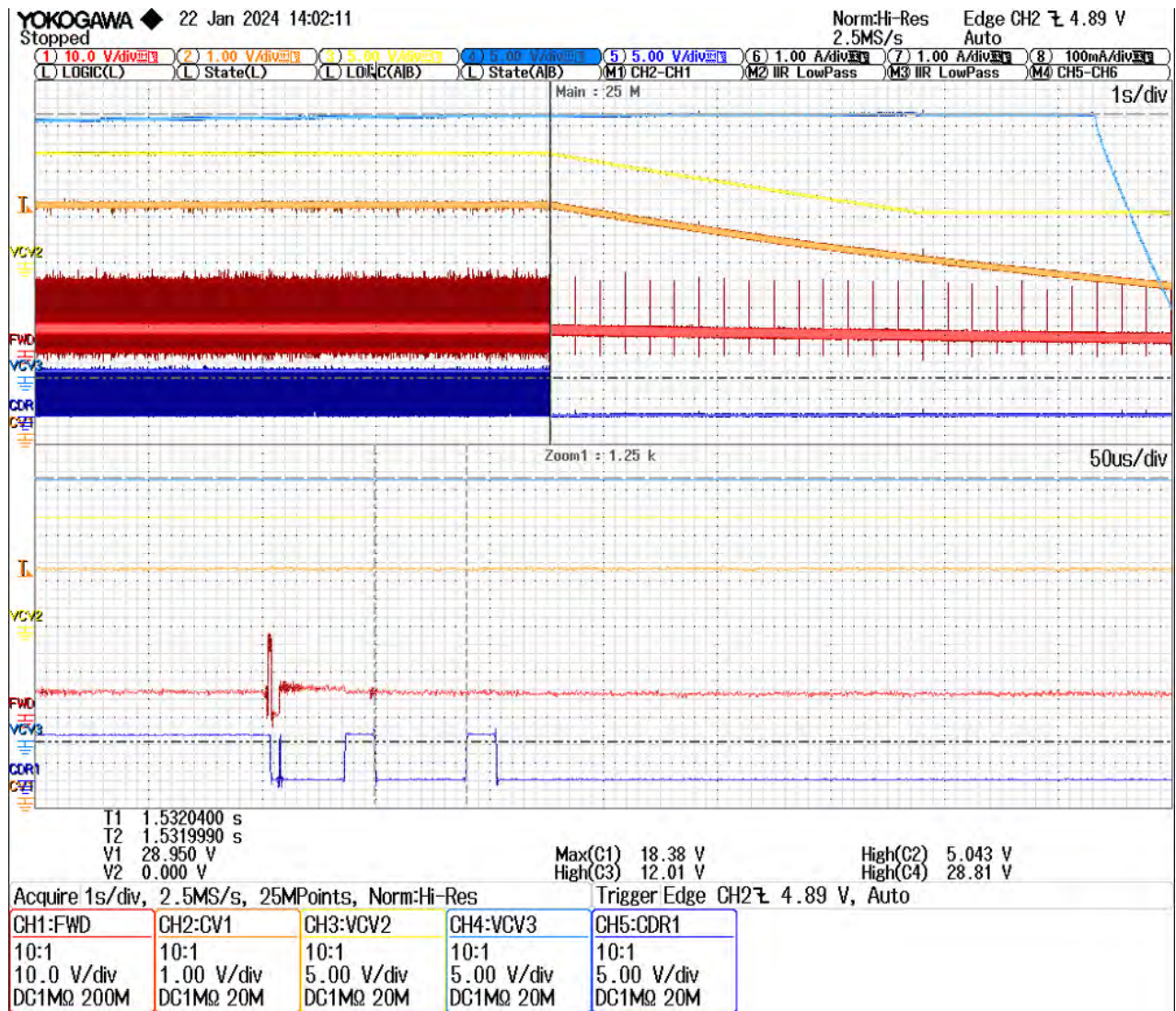

Figure 98 – CV3 OVP at No CV1 and CV2 Load.

### 9.11.2 Output Ripple Measurements

#### 9.11.3 Ripple Measurement Technique

For DC output ripple measurements, a modified oscilloscope test probe was utilized to reduce noise pick-up. Details of the probe modification are provided below in Figure 96.

The probe adapter is shown below. It includes a coaxial cable with two parallel capacitors connected to the points of measurement. The capacitors include a ceramic type and a 10  $\mu\text{F}$  / 50 V aluminum electrolytic type. The aluminum electrolytic type capacitor is polarized, so proper polarity across DC outputs must be ensured.

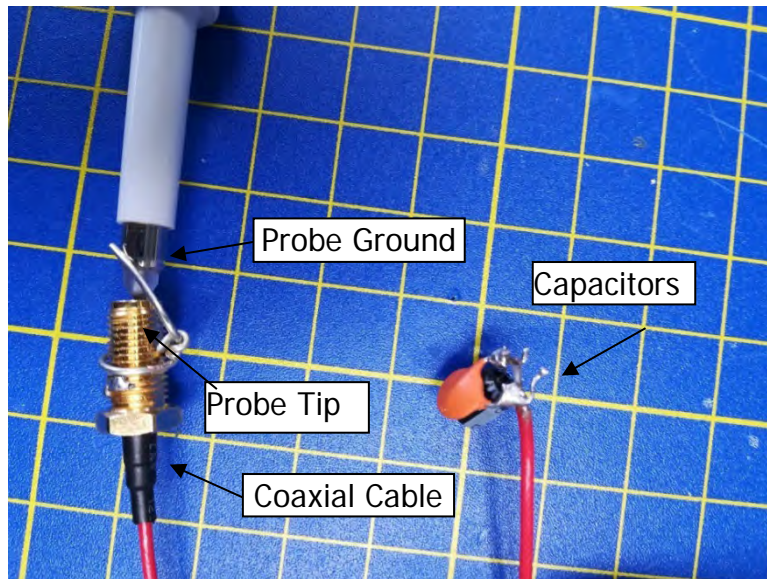

**Figure 99** – Ripple Measurement Test Se-UP.

9.11.4 CV Output Ripple

- 90 VAC – 265 VAC
- Output CV1 = 5 V @ 20 W and output CV2 = 12 V @ 12 W and output CV3 = 24 V @ 30 W
- 20 MHz bandwidth in the scope

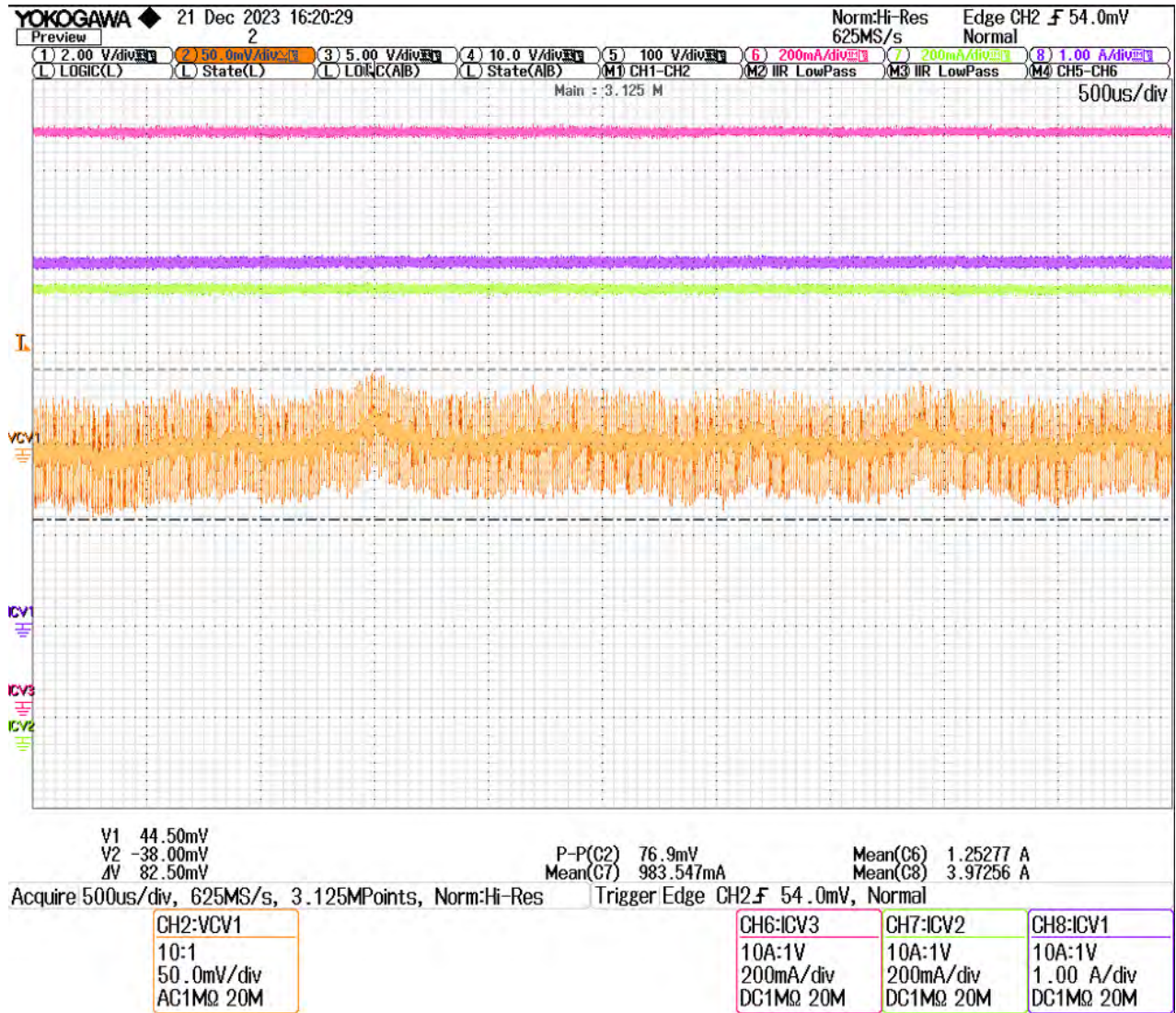

Figure 100 – VCV1 Ripple and Noise Under Nominal Load at 90 VAC.

Ch2: V<sub>CV1</sub>, Ch6: I<sub>CV3</sub>, Ch7: I<sub>CV2</sub>, Ch8: I<sub>CV1</sub>

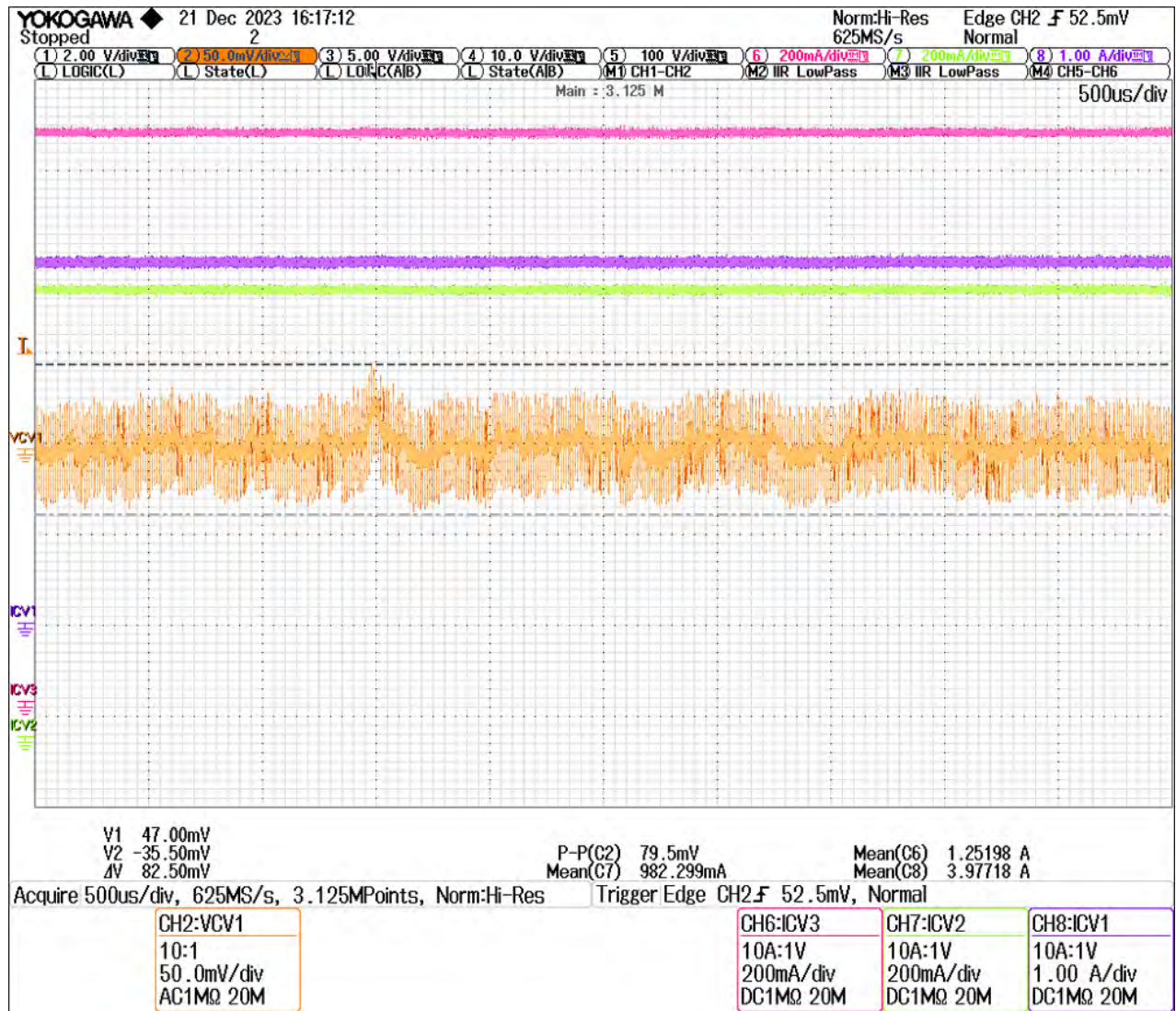

Figure 101 – VCV1 Ripple and Noise Under Nominal Load at 265 VAC.

Ch2: V<sub>CV1</sub>, Ch6: I<sub>CV3</sub>, Ch7: I<sub>CV2</sub>, Ch8: I<sub>CV1</sub>

The worst-case ripple and noise at the CV1 output of the converter was measured as 80 mV<sub>P-P</sub> (<2%) at 20 MHz bandwidth at the connector output.



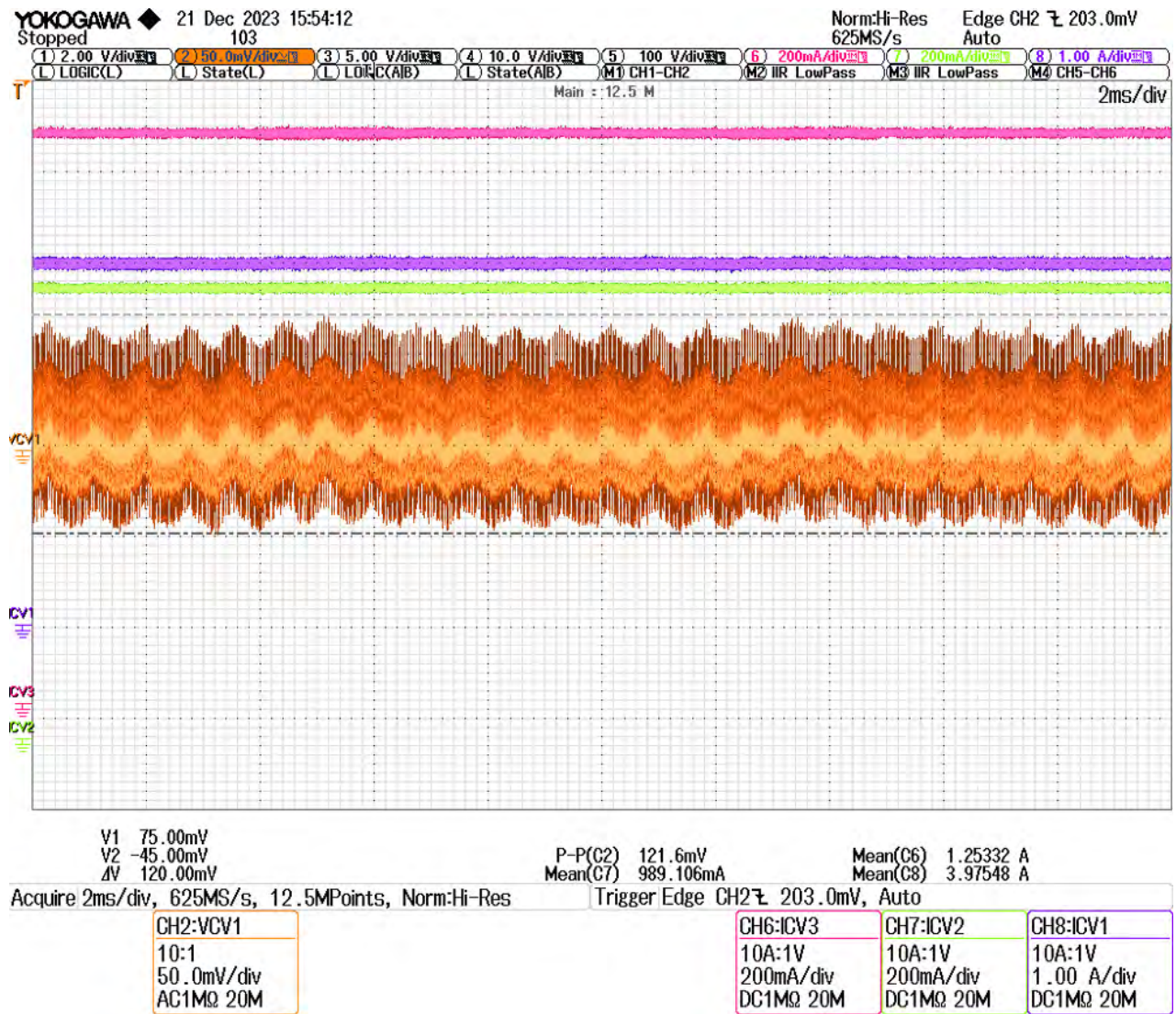

Figure 102 – VCV2 Ripple and Noise Under Nominal Load at 90 VAC.

Ch2: V<sub>CV2</sub>, Ch6: I<sub>CV3</sub>, Ch7: I<sub>CV2</sub>, Ch8: I<sub>CV1</sub>

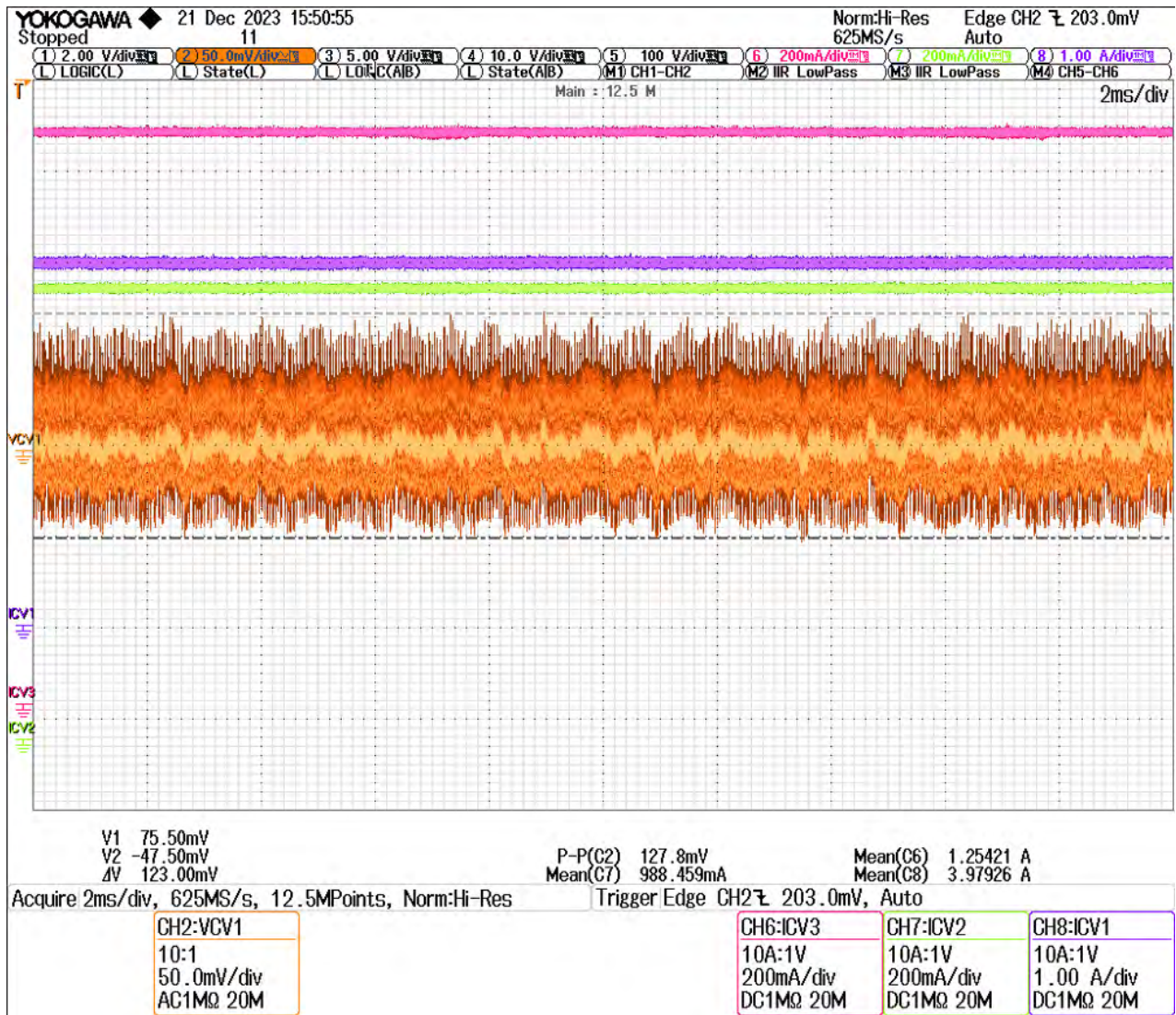

Figure 103 – VCV2 Ripple and Noise Under Nominal Load at 265 VAC.

Ch2: V<sub>CV2</sub>, Ch6: I<sub>CV3</sub>, Ch7: I<sub>CV2</sub>, Ch8: I<sub>CV1</sub>

The worst-case ripple and noise at the CV2 output of the converter was measured as 128 mV<sub>P-P</sub> (<2%) at 20 MHz bandwidth at the connector output.

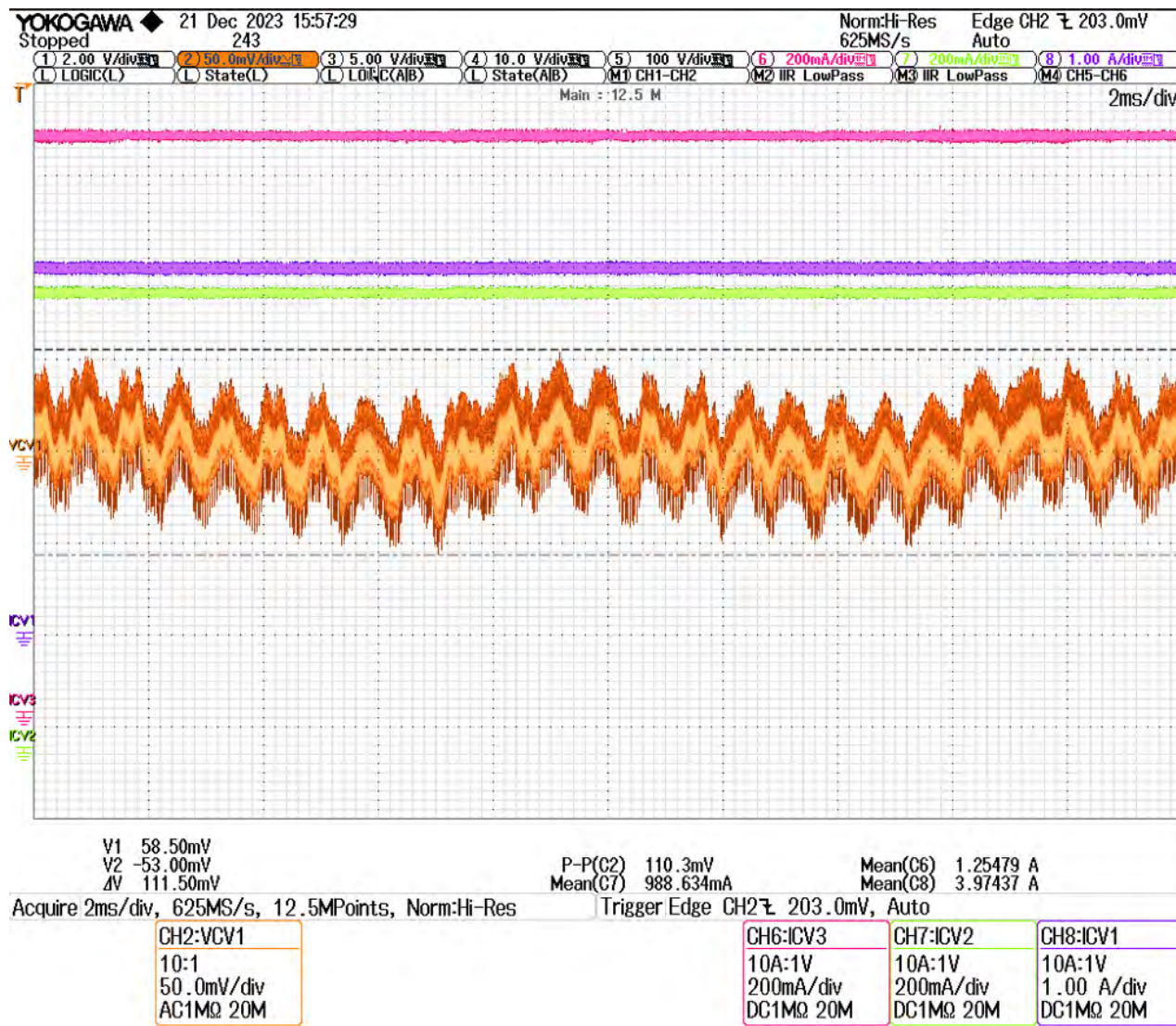

Figure 104 – VCV3 Ripple and Noise Under Nominal Load at 90 VAC.

Ch2: V<sub>CV3</sub>, Ch6: I<sub>CV3</sub>, Ch7: I<sub>CV2</sub>, Ch8: I<sub>CV1</sub>

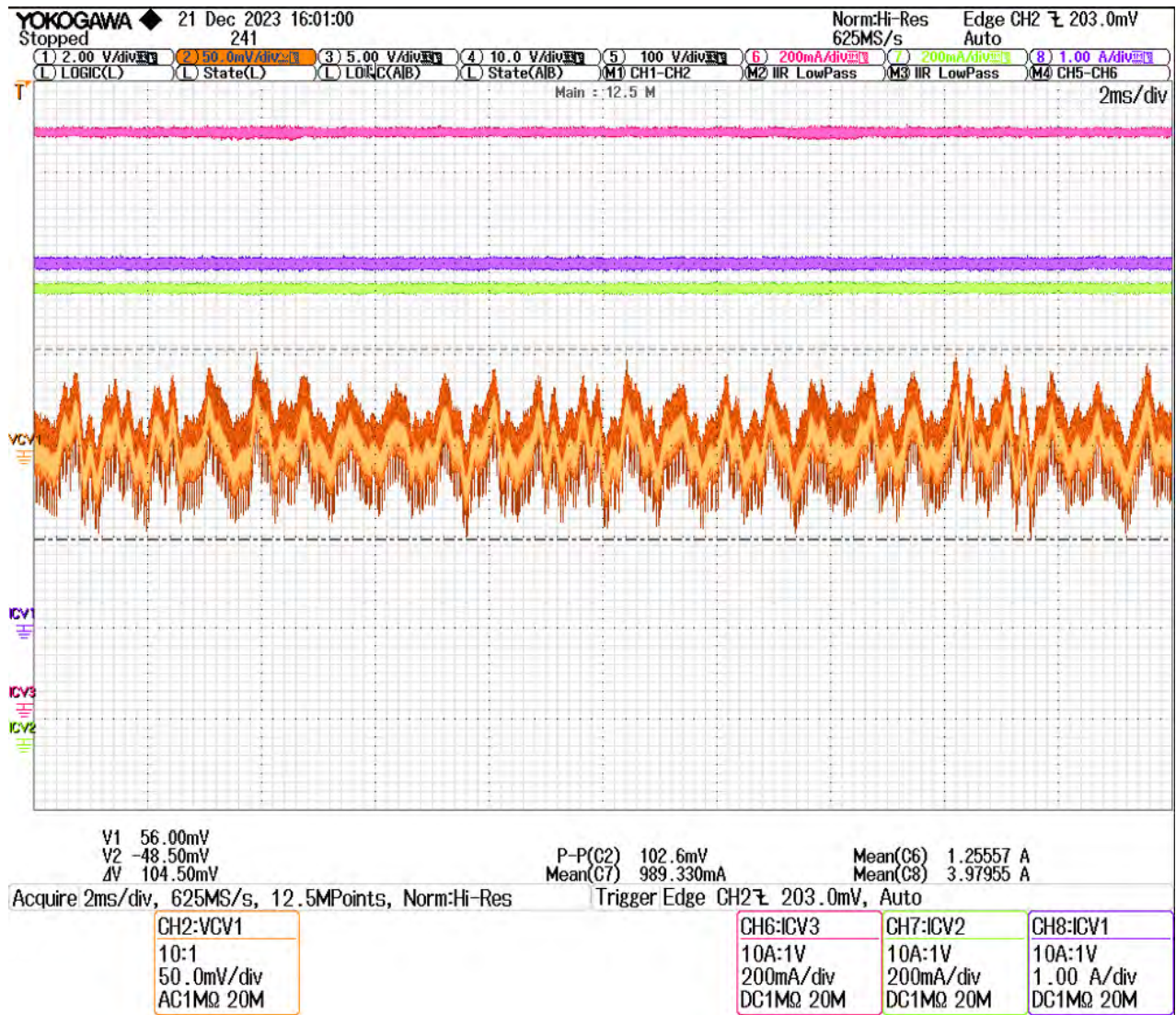

Figure 105 – VCV3 Ripple and Noise Under Nominal Load at 265 VAC.

Ch2: VCV3, Ch6: ICV3, Ch7: ICV2, Ch8: ICV1

The worst-case ripple and noise at the CV2 output of the converter was measured as 110 mV<sub>P-P</sub> (<1%) at 20 MHz bandwidth at the connector output.

### 9.12 Conducted EMI

The EMI scans were carried out at full power without Earth(PE) connection.

The conducted emissions were more than 6 dB below the limits set by CISPR22B / EN55022B.

#### 9.12.1 Line Input 115 VAC

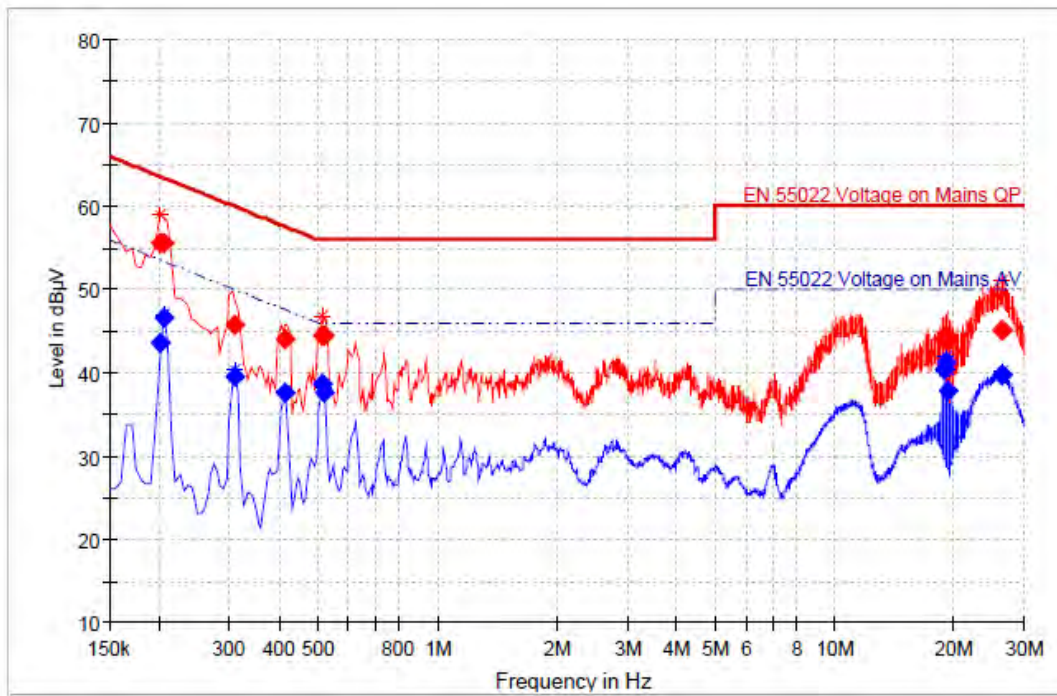

#### Final Result

Frequency (MHz)	QuasiPeak (dBµV)	Average (dBµV)	Limit (dBµV)	Margin (dB)	Bandwidth (kHz)	Line	Filter	Corr. (dB)
0.200000	55.56	---	63.61	8.05	10.000	N	ON	20.3
0.200000	---	43.62	53.61	9.99	10.000	N	ON	20.3
0.205000	---	46.51	53.41	6.89	10.000	N	ON	20.3
0.205000	55.64	---	63.41	7.76	10.000	N	ON	20.3
0.310000	---	39.45	49.97	10.52	10.000	N	ON	20.3
0.310000	45.73	---	59.97	14.24	10.000	N	ON	20.3
0.415000	43.93	---	57.55	13.62	10.000	N	ON	20.4
0.415000	---	37.67	47.55	9.88	10.000	N	ON	20.4
0.515000	---	38.59	46.00	7.41	10.000	N	ON	20.4
0.515000	44.39	---	56.00	11.61	10.000	N	ON	20.4
0.520000	---	37.60	46.00	8.40	10.000	N	ON	20.4
0.520000	44.53	---	56.00	11.47	10.000	N	ON	20.4
18.940000	---	40.31	50.00	9.69	10.000	L1	ON	20.4
18.940000	43.99	---	60.00	16.01	10.000	L1	ON	20.4
19.150000	---	41.23	50.00	8.77	10.000	L1	ON	20.4
19.150000	44.46	---	60.00	15.54	10.000	L1	ON	20.4
19.355000	---	37.89	50.00	12.11	10.000	L1	ON	20.4
19.355000	43.78	---	60.00	16.22	10.000	L1	ON	20.4
26.225000	---	39.73	50.00	10.27	10.000	L1	ON	20.4
26.225000	45.16	---	60.00	14.84	10.000	L1	ON	20.4
26.365000	---	39.71	50.00	10.29	10.000	L1	ON	20.4
26.365000	45.18	---	60.00	14.82	10.000	L1	ON	20.4

Figure 106 – EMI Test Results at 115 V.

9.12.2 Line Input 230 VAC

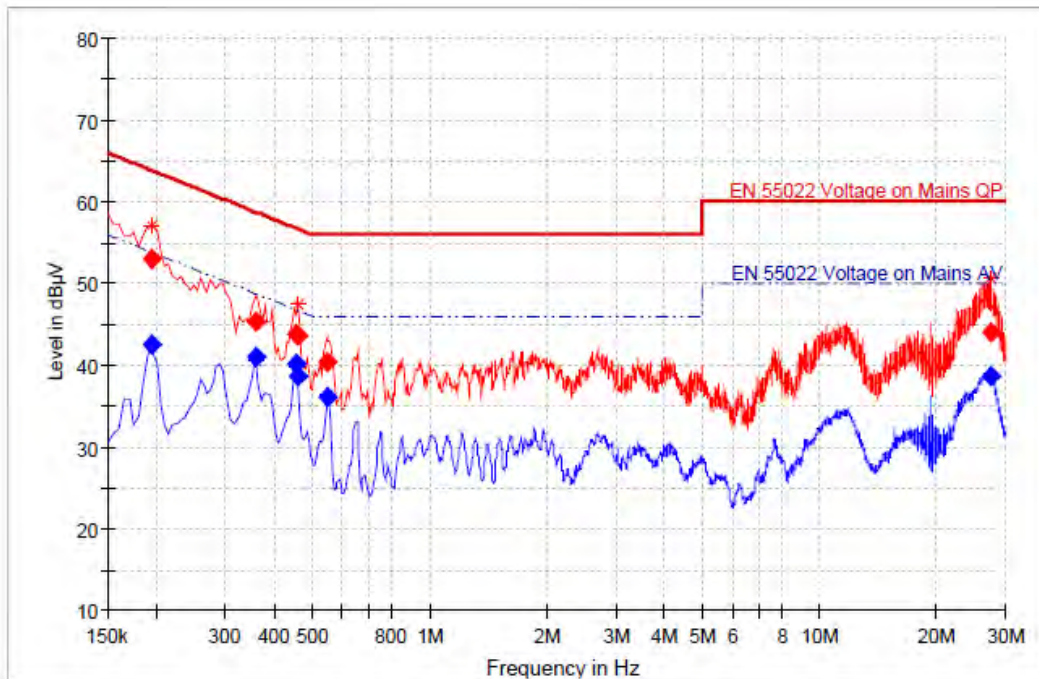

**Final Result**

Frequency (MHz)	QuasiPeak (dBµV)	Average (dBµV)	Limit (dBµV)	Margin (dB)	Bandwidth (kHz)	Line	Filter	Corr. (dB)
0.195000	52.94	---	63.82	10.88	10.000	N	ON	20.3
0.195000	---	42.62	53.82	11.20	10.000	N	ON	20.3
0.360000	---	40.94	48.73	7.79	10.000	N	ON	20.4
0.360000	45.23	---	58.73	13.50	10.000	N	ON	20.4
0.455000	43.90	---	56.78	12.89	10.000	N	ON	20.4
0.455000	---	40.26	46.78	6.53	10.000	N	ON	20.4
0.460000	43.66	---	56.69	13.04	10.000	N	ON	20.4
0.460000	---	38.73	46.69	7.97	10.000	N	ON	20.4
0.550000	40.49	---	56.00	15.51	10.000	N	ON	20.4
0.550000	---	36.21	46.00	9.79	10.000	N	ON	20.4
27.405000	---	38.65	50.00	11.35	10.000	L1	ON	20.4
27.405000	44.05	---	60.00	15.95	10.000	L1	ON	20.4

Figure 107 – EMI Test Results at 230 V.

### 9.13 Thermal Performance

There are no heat sinks in cooling arrangements of the assembly. Copper pours are used for the cooling of the control IC. No forced air-cooling was deployed during the test. The temperatures of the hottest components in the assembly are shown in Table.

Ambient temperature is 25 ±2 °C.

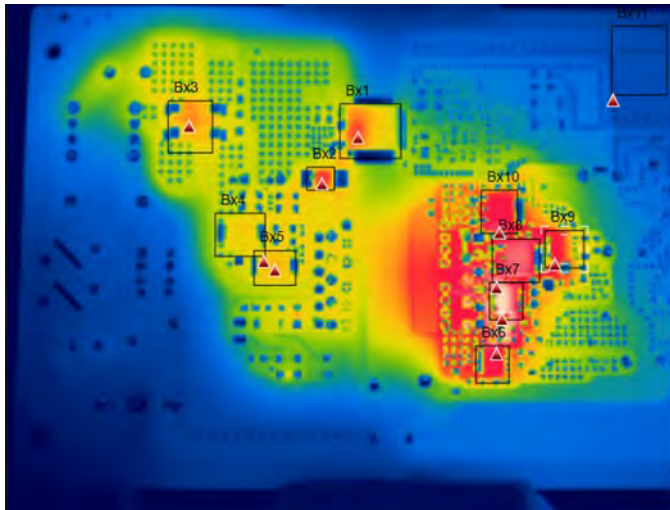

U1 InnoMux2-BL IC	BX1	82.7
D2 Pri Snubber Diode	BX2	83.7
BR1 Bridge Diode	BX3	80.2
VR1 Pri Snubber	BX4	73.2
VR2 Pri Snubber	BX5	74.7
Q2 CV1 Selection Fet	BX6	91.2
Q1 SR Fet	BX7	100
D5 CV2 Diode	BX8	94.8
Q4 CV2 Selection Fet	BX9	87.5
D3 CV3 Diode	BX10	90.5

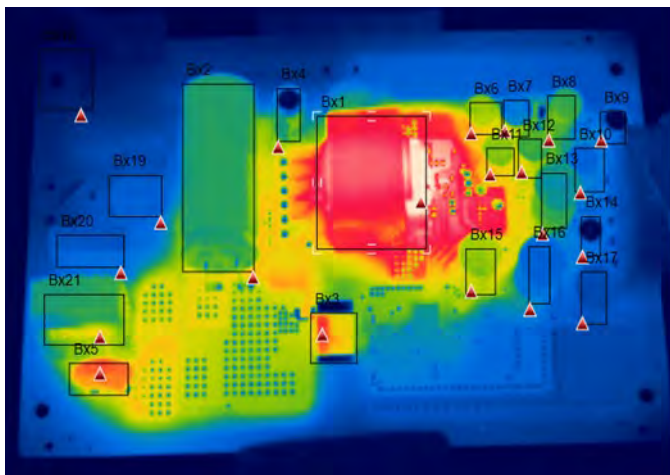

T1 Transformer	BX1	103.7
C3 Bulk Capacitor	BX2	72.7
U1 InnoMux2-BL IC	BX3	82.4
C48 Pri Bias Capacitor	BX4	61.3
R12 Thermistor	BX5	80.9
C10 CV1 Output Capacitor	BX6	76.5
C25 CV1 Output Capacitor	BX7	67.5
L2 CV1 Output Inductor	BX8	61.1
C44 CV1 Output Capacitor	BX9	49
C26 CV1 Output Capacitor	BX10	54.5
C13 CV2 Output Capacitor	BX11	74.7
C35 CV2 Output Capacitor	BX12	69
L3 CV2 Output Inductor	BX13	60.1
C43 CV2 Output Capacitor	BX14	48.3
C14 CV3 Output Capacitor	BX15	66.6
L5 CV3 Output Inductor	BX16	52.8
C15 CV3 Output Capacitor	BX17	42.2

Figure 108 – Line = 90 V Nominal Power - Thermal Image - Bottom and Top Views.

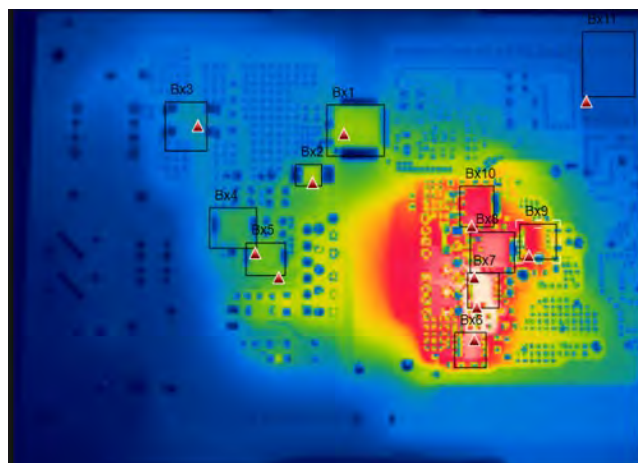

U1 InnoMux2-BL IC	BX1	63.1
D2 Pri Snubber Diode	BX2	63.4
BR1 Bridge Diode	BX3	53.3
VR1 Pri Snubber	BX4	59.3
VR2 Pri Snubber	BX5	61.3
Q2 CV1 Selection Fet	BX6	97.8
Q1 SRFet	BX7	107.7
D5 CV2 Diode	BX8	100.8
Q4 CV2 Selection Fet	BX9	88.2
D3 CV3 Diode	BX10	91.4

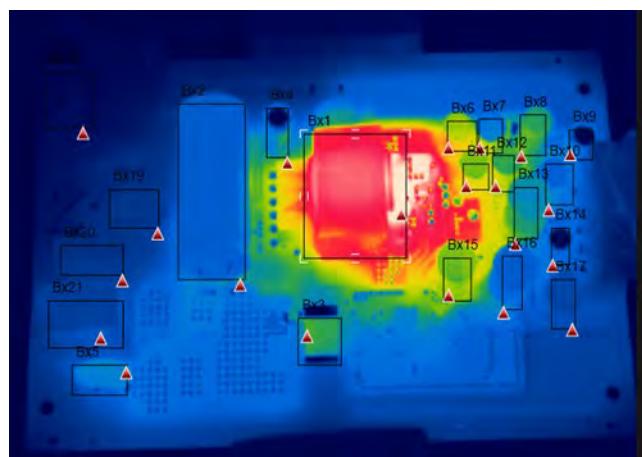

T1 Transformer	BX1	107.2
C3 Bulk Capacitor	BX2	57
U1 InnoMux2-BL IC	BX3	61
C48 Pri Bias Capacitor	BX4	59.6
R12 Thermistor	BX5	54.2
C10 CV1 Output Capacitor	BX6	81.8
C25 CV1 Output Capacitor	BX7	70.9
L2 CV1 Output Inductor	BX8	63.6
C44 CV1 Output Capacitor	BX9	50.8
C26 CV1 Output Capacitor	BX10	55.7
C13 CV2 Output Capacitor	BX11	77
C35 CV2 Output Capacitor	BX12	71.1
L3 CV2 Output Inductor	BX13	62.3
C43 CV2 Output Capacitor	BX14	49.4
C14 CV3 Output Capacitor	BX15	67.2
L5 CV3 Output Inductor	BX16	53.4
C15 CV3 Output Capacitor	BX17	43.2

Figure 109 – Line = 265 V Nominal Power - Thermal Image - Bottom and Top Views.



9.13.1 Audible Noise Performance

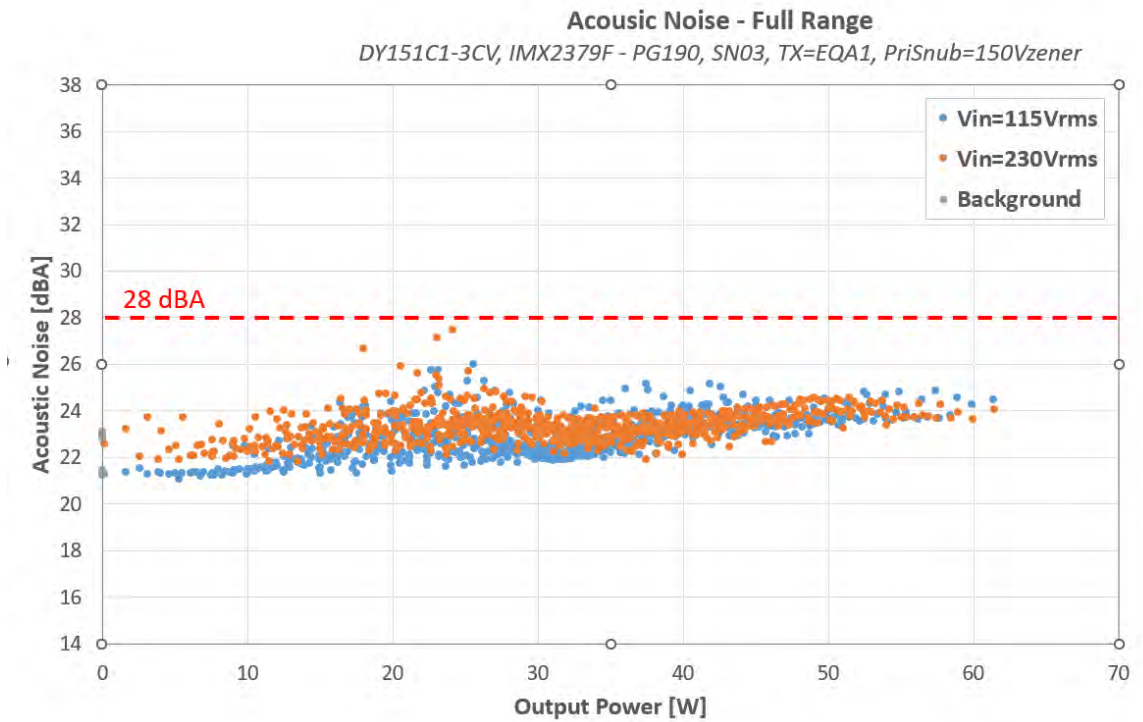

Figure 110 – Audible Noise at Normal Operation Mode.

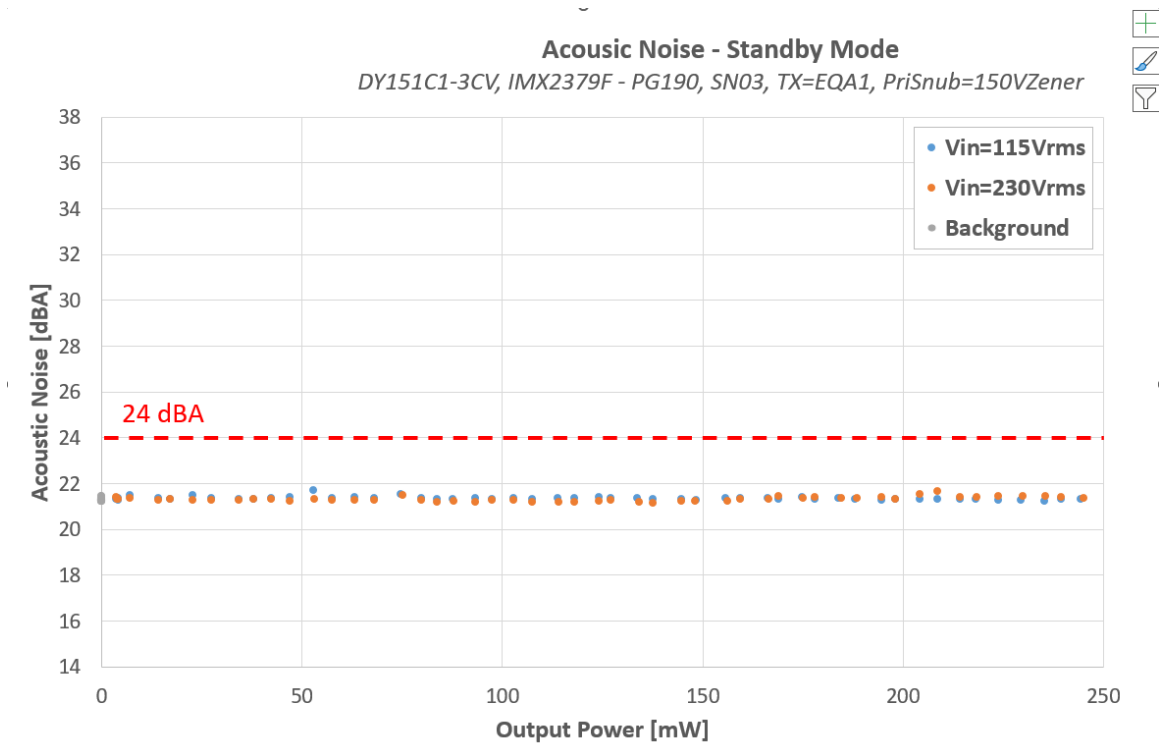

Figure 111 – Audible Noise at Standby Mode.

### 9.13.2 Combination Wave Surge Test

The unit was subjected to  $\pm 1000$  V differential mode and  $\pm 2000$  V common mode combination wave surge at several line phase angles with 5 strikes for each condition.

A test failure was defined as an output latch-off that needs operator intervention to recover, or a complete loss of function that is not recoverable.

### 9.13.3 Differential Mode Surge (L1 to L2), 230 VAC Input

Surge Level (V)	Injection Location	Injection Phase (°)	Test Result
+1000	L1 to L2	0	Pass
-1000	L1 to L2	0	Pass
+1000	L1 to L2	90	Pass
-1000	L1 to L2	90	Pass
+1000	L1 to L2	180	Pass
-1000	L1 to L2	180	Pass
+1000	L1 to L2	270	Pass
-1000	L1 to L2	270	Pass

**Figure 112** – Differential Mode Surge Test Result.

### 9.13.4 Common Mode Surge (L1 to PE), 230 VAC Input

Surge level (V)	Injection Location	Injection Phase (°)	Test Result
+2000	L1 to PE	0	Pass
-2000	L1 to PE	0	Pass
+2000	L1 to PE	90	Pass
-2000	L1 to PE	90	Pass
+2000	L1 to PE	180	Pass
-2000	L1 to PE	180	Pass
+2000	L1 to PE	270	Pass
-2000	L1 to PE	270	Pass

**Figure 113** – Common Mode Surge Test Result – L1 to PE.

*PE is connected to secondary GND to perform common mode test.*

## 9.13.5 Common Mode Surge (L2 to PE), 230 VAC Input

Surge Level (V)	Injection Location	Injection Phase (°)	Test Result
+2000	L2 to PE	0	Pass
-2000	L2 to PE	0	Pass
+2000	L2 to PE	90	Pass
-2000	L2 to PE	90	Pass
+2000	L2 to PE	180	Pass
-2000	L2 to PE	180	Pass
+2000	L2 to PE	270	Pass
-2000	L2 to PE	270	Pass

**Figure 114** – Common Mode Surge Test Result – L2 to PE.

*PE is connected to secondary GND to perform common mode test.*

## 9.13.6 Common Mode Surge (L1+L2+PE, 230 VAC Input)

Surge Level (V)	Injection Location	Injection Phase (°)	Test Result
+2000	L1, L2 and PE	0	Pass
-2000	L1, L2 and PE	0	Pass
+2000	L1, L2 and PE	90	Pass
-2000	L1, L2 and PE	90	Pass
+2000	L1, L2 and PE	180	Pass
-2000	L1, L2 and PE	180	Pass
+2000	L1, L2 and PE	270	Pass
-2000	L1, L2 and PE	270	Pass

**Figure 115** – Common Mode Surge Test Result – L1, L2 and PE

*PE is connected to secondary GND to perform common mode test.*

**10 Revision History**

Date	Author	Revision	Description & Changes	Reviewed
26-Feb-24	FT	1.0	Draft Release.	Apps

For the latest updates, visit our website: [www.power.com](http://www.power.com)

Reference Designs are technical proposals concerning how to use Power Integrations' gate drivers in particular applications and/or with certain power modules. These proposals are "as is" and are not subject to any qualification process. The suitability, implementation and qualification are the sole responsibility of the end user. The statements, technical information and recommendations contained herein are believed to be accurate as of the date hereof. All parameters, numbers, values and other technical data included in the technical information were calculated and determined to our best knowledge in accordance with the relevant technical norms (if any). They may be based on assumptions or operational conditions that do not necessarily apply in general. We exclude any representation or warranty, express or implied, in relation to the accuracy or completeness of the statements, technical information and recommendations contained herein. No responsibility is accepted for the accuracy or sufficiency of any of the statements, technical information, recommendations or opinions communicated and any liability for any direct, indirect or consequential loss or damage suffered by any person arising therefrom is expressly disclaimed.

Power Integrations reserves the right to make changes to its products at any time to improve reliability or manufacturability. Power Integrations does not assume any liability arising from the use of any device or circuit described herein. POWER INTEGRATIONS MAKES NO WARRANTY HEREIN AND SPECIFICALLY DISCLAIMS ALL WARRANTIES INCLUDING, WITHOUT LIMITATION, THE IMPLIED WARRANTIES OF MERCHANTABILITY, FITNESS FOR A PARTICULAR PURPOSE, AND NON-INFRINGEMENT OF THIRD PARTY RIGHTS.

#### Patent Information

The products and applications illustrated herein (including transformer construction and circuits' external to the products) may be covered by one or more U.S. and foreign patents, or potentially by pending U.S. and foreign patent applications assigned to Power Integrations. A complete list of Power Integrations' patents may be found at [www.power.com](http://www.power.com). Power Integrations grants its customers a license under certain patent rights as set forth at <http://www.power.com/ip.htm>.

Power Integrations, the Power Integrations logo, CAPZero, ChiPhy, CHY, DPA-Switch, EcoSmart, E-Shield, eSIP, eSOP, HiperLCS, HiperPLC, HiperPFS, HiperTFS, InnoSwitch, Innovation in Power Conversion, InSOP, LinkSwitch, LinkZero, LYTSwitch, SENZero, TinySwitch, TOPSwitch, PI, PI Expert, PowiGaN, SCALE, SCALE-1, SCALE-2, SCALE-3 and SCALE-iDriver, are trademarks of Power Integrations, Inc. Other trademarks are property of their respective companies. ©2022, Power Integrations, Inc.

## Power Integrations Worldwide Sales Support Locations

#### WORLD HEADQUARTERS

5245 Hellyer Avenue  
San Jose, CA 95138, USA.  
Main: +1-408-414-9200  
Customer Service:  
Worldwide: +1-65-635-64480  
Americas: +1-408-414-9621  
e-mail: [usasales@power.com](mailto:usasales@power.com)

#### CHINA (SHANGHAI)

Rm 2410, Charity Plaza, No. 88,  
North Caoxi Road,  
Shanghai, PRC 200030  
Phone: +86-21-6354-6323  
e-mail: [chinasales@power.com](mailto:chinasales@power.com)

#### CHINA (SHENZHEN)

17/F, Hivac Building, No. 2, Keji  
Nan 8th Road, Nanshan District,  
Shenzhen, China, 518057  
Phone: +86-755-8672-8689  
e-mail: [chinasales@power.com](mailto:chinasales@power.com)

#### GERMANY

(AC-DC/LED/Motor Control Sales)  
Einsteinring 24  
85609 Dornach/Aschheim  
Germany  
Tel: +49-89-5527-39100  
e-mail: [eurosales@power.com](mailto:eurosales@power.com)

#### GERMANY (Gate Driver Sales)

HellwegForum 3  
59469 Ense  
Germany  
Tel: +49-2938-64-39990  
e-mail: [igbt-driver.sales@power.com](mailto:igbt-driver.sales@power.com)

#### INDIA

#1, 14<sup>th</sup> Main Road  
Vasanthanagar  
Bangalore-560052  
India  
Phone: +91-80-4113-8020  
e-mail: [indiasales@power.com](mailto:indiasales@power.com)

#### ITALY

Via Milanese 20, 3<sup>rd</sup>. Fl.  
20099 Sesto San Giovanni (MI) Italy  
Phone: +39-024-550-8701  
e-mail: [eurosales@power.com](mailto:eurosales@power.com)

#### JAPAN

Yusen Shin-Yokohama 1-chome Bldg.  
1-7-9, Shin-Yokohama, Kohoku-ku  
Yokohama-shi,  
Kanagawa 222-0033 Japan  
Phone: +81-45-471-1021  
e-mail: [japansales@power.com](mailto:japansales@power.com)

#### KOREA

RM 602, 6FL  
Korea City Air Terminal B/D,  
159-6  
Samsung-Dong, Kangnam-Gu,  
Seoul, 135-728 Korea  
Phone: +82-2-2016-6610  
e-mail: [koreasales@power.com](mailto:koreasales@power.com)

#### SINGAPORE

51 Newton Road,  
#19-01/05 Goldhill Plaza  
Singapore, 308900  
Phone: +65-6358-2160  
e-mail: [singaporesales@power.com](mailto:singaporesales@power.com)

#### TAIWAN

5F, No. 318, Nei Hu Rd.,  
Sec. 1  
Nei Hu District  
Taipei 11493, Taiwan R.O.C.  
Phone: +886-2-2659-4570  
e-mail: [taiwansales@power.com](mailto:taiwansales@power.com)

#### UK

Building 5, Suite 21  
The Westbrook Centre  
Milton Road  
Cambridge  
CB4 1YG  
Phone: +44 (0) 7823-557484  
e-mail: [eurosales@power.com](mailto:eurosales@power.com)

